



"CJT" SERIES HYDRAULIC CYLINDERS

Standard Type : CJT35 / CJT70 / CJT140 / CJT210

Switch Set Type : CJT35L / CJT70L / CJT140L

ACTUATORS

Up to 21 MPa (3530 PSI)

YUKEN's "CJT" Series Hydraulic Cylinders based on JIS B 8354 are provided with many mounting types so that they can be used for wide use of general purpose industrial machines such as machine tools.

Moreover, Switch-Set "CJT" Series Hydraulic Cylinders with a proximity switch which facilitates detecting a position with a slide proximity switch on the cylinder body is also available.

- Various mounting types
- Excellent ability in low speed and high-precision operation.
- Gentle stop characteristics obtained with a smooth cushion effect.

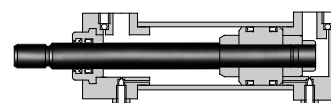

Specifications

Description	Standard Type				Switch Set Type			
	CJT35	CJT70	CJT140	CJT210	CJT35L	CJT70L	CJT140L	
Cylinder Bore mm (In.)	Refer to the "Cylinder Bore Selection Chart"							
Nominal Pressure MPa (PSI)	3.5 (510)	7 (1020)	14 (2030)	21 (3050)	3.5 (510)	7 (1020)	14 (2030)	
Min. Operating Pressure MPa (PSI)	Less than 0.1 (14.5)	Less than 0.3 (43.5)	Less than 0.3 (43.5)	Less than 0.3 (43.5)	Less than 0.1 (14.5)	Less than 0.3 (43.5)	Less than 0.3 (43.5)	
Operating Speed mm/s (In./s)	8 - 300 (.31 - 11.8)	8 - 400 * ¹ (.31 - 15.7)		8 - 300 (.31 - 11.8)	8 - 300 (.31 - 11.8)	8 - 400 * ¹ (.31 - 15.7)		
Max. Stroke * ² mm (In.)	1800 (70.9)	2000 (78.7)			1600 (63.0)	2000 (78.7)		

★ 1. Max. Operating Speed is varied according to the Cylinder Bore.

★ 2. Max. Stroke may be varied according to the Cylinder Bore. It also may be limited to lower value according to buckling strength. For details, consult Yuken.

Cylinder Bore Selection Chart

Cylinder Bore mm(In.)	Standard Type				Switch Set Type		
	CJT 35	CJT 70	CJT 140	CJT 210	CJT 35L	CJT 70L	CJT 140L
32 (1.26)	○	○	○		○	○	○
40 (1.57)	○	○	○	○	○	○	○
50 (1.97)	○	○	○	○	○	○	○
63 (2.48)	○	○	○	○	○	○	○
80 (3.15)	○	○	○	○	○	○	○
100 (3.94)	○	○	○	○		○	○
125 (4.92)	○	○	○	○		○	○
140 (5.51)		○	○	○			
150 (5.91)		○	○				
160 (6.30)	○	○	○	○			
180 (7.09)		○	○				
200 (7.87)		○	○				
220 (8.66)		○	○				
250 (9.84)		○	○				

★ The mark ○ in above chart show selectable Cylinder Bore.

Graphic Symbols

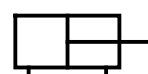

Std. Type

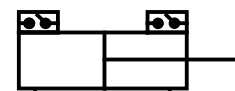

Switch Set Type

This catalogue introduces the outline of CJT Series Hydraulic Cylinders. Consult Yuken when detailed material such as dimensions figures is required.

Model Number Designation

Model Number Designation

Standard Type

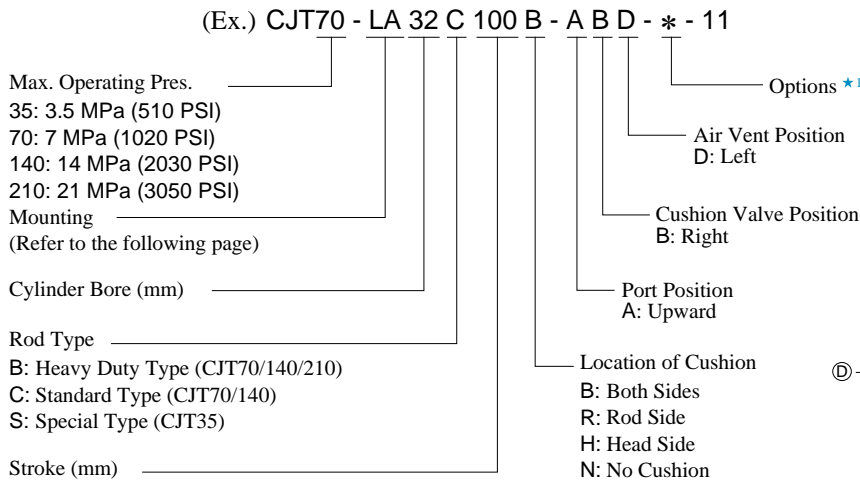

*1. Consult YUKEN when options is required.

Switch Set Type

Composition of basic model code is the same as of the above mentioned standard type. However the following underlined marks shall be added.

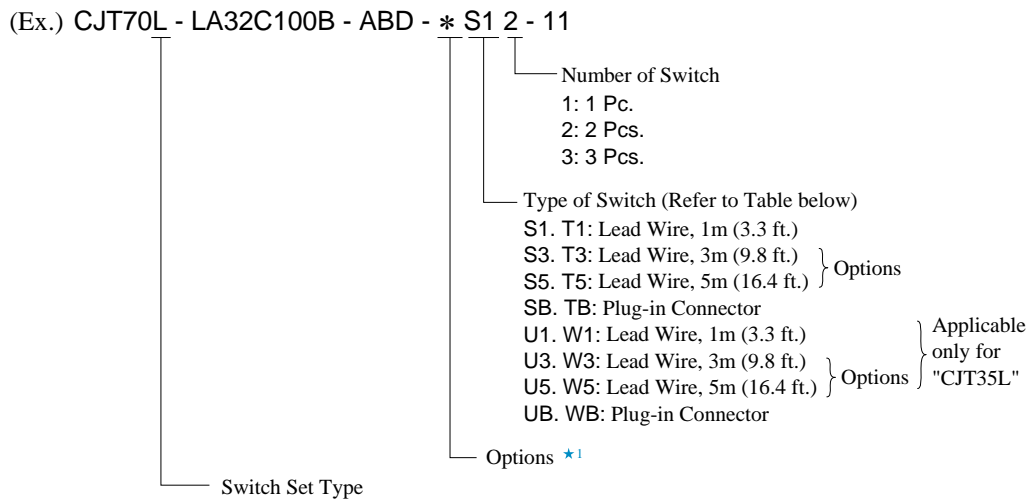

* Consult Yuken when options is required.

Specification of Switch

Type	Usage	Max. Load	Indicator Light	
Contact Switch	S1, S3, S5 (Lead Wire) SB (Plug-in Connector)	AC/DC for Relay & Sequencer	24 V DC, 5-50 mA 100 V AC, 7-20 mA 200 V AC, 7-10 mA	Lighting when switch is ON
	T1, T3, T5 (Lead Wire) TB (Plug-in Connector)	Large Volume Relay	100 V AC, 20-200 mA 200 V AC, 10-200 mA	Lighting when switch is OFF
Contactless Switch	U1, U3, U5 (Lead Wire) UB (Plug-in Connector)	AC for Relay & Sequencer	85-265 V AC, 5-100 mA	Lighting when switch is ON
	W1, W3, W5 (Lead Wire) WB (Plug-in Connector)	DC for Relay & Sequencer	10-30 V DC, 5-30 mA	

Mounting

Mounting

Symbol	Name	Illustration of Mounting Type	CJT35 CJT35L	CJT70	CJT140	CJT210
LA	Foot Mounting Side Lugs		<input type="radio"/>	<input type="radio"/>	<input type="radio"/>	<input type="radio"/>
LB	Foot Mounting Side End Angles		<input type="radio"/>	<input type="radio"/>	<input type="radio"/>	
FA	Rod Rectangular Flange		<input type="radio"/>	<input type="radio"/>		<input type="radio"/>
FE				<input type="radio"/>	<input type="radio"/>	
FY				<input type="radio"/>	<input type="radio"/>	
FB	Head Rectangular Flange		<input type="radio"/>	<input type="radio"/>		<input type="radio"/>
FF				<input type="radio"/>	<input type="radio"/>	
FC	Rod Square Flange			<input type="radio"/>	<input type="radio"/>	
FD	Head Square Flange			<input type="radio"/>	<input type="radio"/>	
CA	Cap Detachable Eye		<input type="radio"/>	<input type="radio"/>	<input type="radio"/>	<input type="radio"/>
CB	Cap Detachable Clevis		<input type="radio"/>	<input type="radio"/>	<input type="radio"/>	
TA	Rod Trunnion		<input type="radio"/>	<input type="radio"/>	<input type="radio"/>	
TC	Intermediate Trunnion		<input type="radio"/>	<input type="radio"/>	<input type="radio"/>	<input type="radio"/>
SD	Basic Type		<input type="radio"/>	<input type="radio"/>	<input type="radio"/>	<input type="radio"/>

● The mark ○ in above chart show selectable Mounting Types.

