

Specifications

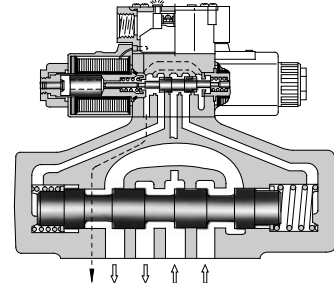

■ Specifications

Valve Type	Model Numbers	Max. Flow ^{*1} L/min (U.S.GPM)	Max. Operating Pressure MPa(PSI)	Max. Pilot Pressure MPa(PSI)	Min ^{*2} Required Pilot Pres. MPa(PSI)	Max. T-Line Back Pressure MPa(PSI)		Max. Change-over Frequency min ⁻¹ (Cycles/Min)			Approx. Mass kg(lbs.)
						Ext.Drain	Int.Drain	AC	DC	R	
Standard Type	DSHG-01-3C*-13/1380/1390	40 (10.6)	21 (3050)	21 (3050)	1.0 (150)	16 (2320)	16 (2320)	120	120	120	3.5 (7.7)
	DSHG-01-2B*-13/1380/1390										2.9 (6.4)
	DSHG-03-3C*-13/1390	160 (42.3)	25 (3630)	25 (3630)	0.7 (100)	16 (2320)	16 (2320)	120	120	120	7.2(15.9)
	DSHG-03-2N*-13/1390										7.2(15.9)
	DSHG-03-2B*-13/1390										6.6(14.6)
	(S-)DSHG-04-3C*-51/5190										8.8(19.4)
(S-)DSHG-04-2N*-51/5190	300 (79.3)	31.5 (4570)	25 (3630)	0.8 (120)	21 (3050)	16 (2320)	120	120	120	8.8(19.4)	
(S-)DSHG-04-2B*-51/5190										8.2(18.1)	
Shockless Type	(S-)DSHG-06-3C*-52/5290	500 (132)	31.5 (4570)	25 (3630)	0.8 (120) ^{*3}	21 (3050)	16 (2320)	120	120	120	12.7 (28)
	(S-)DSHG-06-2N*-52/5290										12.7 (28)
	(S-)DSHG-06-2B*-52/5290			12.1 (27)							
	(S-)DSHG-06-3H*-52/5290			13.5 (30)							
	(S-)DSHG-10-3C*-42/4290	1100 (291)	31.5 (4570)	25 (3630)	1.0 (150) ^{*3}	21 (3050)	16 (2320)	120	120	100	45.3(100)
	(S-)DSHG-10-2N*-42/4290			21 (3050)				100	100	100	45.3(100)
	(S-)DSHG-10-2B*-42/4290				60			60	50	44.7 (99)	
	(S-)DSHG-10-3H*-42/4290			53.1(117)							

★ 1. The maximum flow means the limited flow without inducing any abnormality to the operation (changeover) of the valve. For details, please refer to the "List of Standard Models and Maximum Flow" on pages 9 to 13.

★ 2. In case of internal drain type valve, the differential pressure between pilot pressure and back pressure at tank port should be kept more than the minimum pilot pressure.

★ 3. The minimum pilot pressure for the valve with pilot piston is 1.8 MPa (260 PSI).

Yuken can offer flanged connection valves described below. Consult Yuken for the details.

Model Numbers	Rated Flow L/min (U.S.GPM)	Max. Pressure MPa (PSI)
DSHF-10-***-27*	315 (83)	21 (3050)
DSHF-16-***-37*	500 (132)	
DSHF-24-***-28*	1200 (317)	
DSHF-32-***-27*	2400 (634)	

Solenoid Ratings / Sub-plates

■ Solenoid Ratings

Valve Type	Electric source	Coil Type	Frequency (Hz)	Voltage (V)		Current & Power at Rated Voltage		
				Source Rating	Serviceable Range	Inrush (A) *	Holding (A)	Power (W)
Standard Type	AC	A100	50	100	80 - 110	2.42	0.51	—
			60	100	90 - 120	2.14	0.37	
		A120	50	120	96 - 132	2.02	0.42	
			60		108 - 144	1.78	0.31	
		A200	50	200	160 - 220	1.21	0.25	
			60		180 - 240	1.07	0.19	
A240	50	240	192 - 264	1.01	0.21			
	60		216 - 288	0.89	0.15			
Shockless Type	DC (K Series)	D12	—	12	10.8 - 13.2	—	2.45	29
		D24		24	21.6 - 26.4		1.23	
		D48		48	43.2 - 52.8		0.61	
	AC → DC Rectified (R)	R100	50/60	100	90 - 110	—	0.33	29
		R200		200	180 - 220		0.16	

★ Inrush current in the above table show rms values at maximum stroke.

The coil type numbers in the shaded column are handled as optional extras. In case these coils are required to be chosen, please confirm the time of delivery with us before ordering.

— CSA Approved Solenoid Valve —

The "DSHG" series valve have been approved by the CSA(Candian Standards Association). consult us for details.

■ Sub-plates

Valve Model Numbers	Japanese Standard "JIS"			European Design Standard			N. American Design Standard		
	Sub-plate Model Numbers	Thread Size	Approx. Mass kg (lbs.)	Sub-plate Model Numbers	Thread Size	Approx. Mass kg (lbs.)	Sub-plate Model Numbers	Thread Size	Approx. Mass kg (lbs.)
DSHG-01	DSGM-01-30	Rc 1/8	0.8 (1.8)	DSGM-01-3080	1/8 BSP.F	0.8 (1.8)	DSGM-01-3090	1/8 NPT	0.8 (1.8)
	DSGM-01X-30	Rc 1/4	0.8 (1.8)	DSGM-01X-3080	1/4 BSP.F	0.8 (1.8)	DSGM-01X-3090	1/4 NPT	0.8 (1.8)
	DSGM-01Y-30	Rc 3/8	0.8 (1.8)	—	—	—	DSGM-01Y-3090	3/8 NPT	0.8 (1.8)
DSHG-03	DSGM-03-40★	Rc 3/8	3.0 (6.6)	DSGM-03-2180★	3/8 BSP.F	3.0 (6.6)	DSGM-03-2190★	3/8 NPT	3.0 (6.6)
	DSGM-03X-40★	Rc 1/2	3.0 (6.6)	DSGM-03X-2180★	1/2 BSP.F	3.0 (6.6)	DSGM-03X-2190★	1/2 NPT	3.0 (6.6)
	DSGM-03Y-40★	Rc 3/4	4.7 (10.4)	DSGM-03Y-2180★	3/4 BSP.F	4.7 (10.4)	DSGM-03Y-2190★	3/4 NPT	4.7 (10.4)
	DHGM-03Y-10	Rc 3/4	4.7 (10.4)	DHGM-03Y-1080	3/4 BSP.F	4.7 (10.4)	DHGM-03Y-1090	3/4 NPT	4.7 (10.4)
DSHG-04	DHGM-04-20	Rc 1/2	4.4 (9.7)	DHGM-04-2080	1/2 BSP.F	4.4 (9.7)	DHGM-04-2090	1/2 NPT	4.4 (9.7)
	DHGM-04X-20	Rc 3/4	4.1 (9.0)	DHGM-04X-2080	3/4 BSP.F	4.1 (9.0)	DHGM-04X-2090	3/4 NPT	4.1 (9.0)
DSHG-06	DHGM-06-50	Rc 3/4	7.4 (16.3)	DHGM-06-5080	3/4 BSP.F	8.5 (18.7)	DHGM-06-5090	3/4 NPT	7.4 (16.3)
	DHGM-06X-50	Rc 1	7.4 (16.3)	DHGM-06X-5080	1 BSP.F	8.5 (18.7)	DHGM-06X-5090	1 NPT	7.4 (16.3)
DSHG-10	DHGM-10-40	Rc 1-1/4	21.5 (47.4)	DHGM-10-4080	1-1/4 BSP.F	21.5 (47.4)	DHGM-10-4090	1-1/4 NPT	21.5 (47.4)
	DHGM-10X-40	Rc 1-1/2	21.5 (47.4)	DHGM-10X-4080	1-1/2 BSP.F	21.5 (47.4)	DHGM-10X-4090	1-1/2 NPT	21.5 (47.4)

★ DSGM-03* is available only for Internal pilot-Internal drain type (Use DHGM-03Y for other valves).

● Sub-plates are available. Specify the sub-plate model number from the table above.
When sub-plates are not used, the mounting surface should have a good machined finish.



Solenoid Controlled Pilot Operated Directional Valves

DSHG-01 / 03 / 04 / 06 / 10

S-DSHG-04 / 06 / 10

Model Number Designation

Model Number Designation

F- Special Seals	S- Type	DSHG-06 Series Number	-2 Valve Size	No. of Valve Position	B Spool-Spring Arrangement	2 Spool Type	A Special Two Position Valve	-C2 Models with Pilot Choke Valve	-E Pilot Connection	T Drain Connection	-R2 Spool Control Modification	-A100 Coil Type	-C Manual Override of Pilot Valve	-H Built-in Orifice for Pilot Line	-N Type of Electrical Conduit Connection	-52 Design Number	-* Design Standard	-L Models with Reverse Mtg. of Solenoid
	None: Stand-ard Type	01	3	C: Spring Centred	2, 3, 4 40, 5, 60 7, 9, 10 11, 12	—	—	—	—	—	—	AC: A100, A200 A120, A240	—	—	None:	13	None: Japanese Standard "JIS"	—
	None: Stand-ard Type	03	3	C: Spring Centred	2, 3, 4 40, 5, 60 7, 9, 10 11, 12	—	—	C1: With C1 Choke	None: Internal Pilot	None: External Drain	R2: With Stroke Adjustment, Both Ends RA: With Stroke Adjustment, Port "A" End RB: With Stroke Adjustment, Port "B" End	AC: R100, R200	None: Manual Override Pin	—	None:	13	90: N: American Design Standard	L (Omit if not required)
	None: Stand-ard Type	04	3	C: Spring Centred	2, 4, 40 60, 10, 12 7, 9, 11	—	—	C2: With C2 Choke	E: External Pilot	T: Internal Drain	R2: With Stroke Adj., Both Ends RA: With Stroke Adj., Port "A" End RB: With Stroke Adj., Port "B" End P2: With Pilot Piston, Both Ends PA: With Pilot Piston, Port "A" End PB: With Pilot Piston, Port "B" End	AC: A100, A200 A120, A240	C: Push Button & Lock Nut	—	N: Plug-in Connector Type	51	None: Japanese Standard "JIS" & European Design Standard	—
	S: Shock-less Type	06	3	H: Pressure Centred	2, 4, 40 60, 10, 12 7, 9, 11	—	—	C1C2: With C1 & C2 Choke (omit if not required)	—	—	—	DC: D12, D24 D48	—	—	N1: Plug-in Connector with Indicator Light	52	80: European Design Standard (Applicable only for DSHG-01)	—
	None: Stand-ard Type	10	2	B: Spring Offset	2, 4, 40 (3, 7) ^{*1}	—	A ^{*2} (Omit if not required)	—	—	—	—	AC: R100, R200	—	—	—	42	90: N: American Design Standard	L (Omit if not required)

Note : In spool type "3", "5", "6", "60", and "7", the combination applicable between pilot system and drain system is as described in the table below.

Pilot Connection	Drain Connection	Care in Application
Internal Pilot	External Drain	Hold back pressure in the tank line so that the difference between pilot pressure and drain pressure is always more than minimum required pilot pressure.
	Internal Drain (T)	Combination is not applicable
External Pilot (E)	External Drain	No restrictions in the combination on us
	Internal Drain (T)	

- ★ 1. Shockless type (S-DSHG) are not available for spool type marked ().
- ★ 2. As for the details of the valve using the neutral position and the side position (either SOL a or SOL b side), please refer to page 14. Furthermore, the spool types other than "2", "4", "40" (3, 7) are also available.
- ★ 3. In spool-spring arrangement "H" (Pressure centred models), the valves with stroke adjustment (R*) and pilot-piston (P*) are not available.
- ★ 4. N1 stands for Plug-in connector with solenoid indicator light. N1 is not available for R-type solenoids.
- ★ 5. In spool-spring arrangement "H" (Pressure centred models), in case the pilot pressure is more than 10 MPa (1450 PSI), please specify that the valve should have the built-in orifice to the pilot line.

In the table above, the symbols and numbers highlighted with shade represent the optional extras. The valves with model number having such optional extras are handles as options, therefore please confirm the time of delivery with us before ordering.

Mounting Bolt

■ Mounting Bolt

Model Numbers	Mounting Bolt				
	Name	Japanese Standard "JIS" European Design Standard	N. American Design Standard	Qty.	Tightening Torque Nm (in. lbs.)
DSHG-01	Mtg. Bolt Kit ^{★3}	MBK-01-01-30 ^{★1} MBK-01-02-30 ^{★2}	MBK-01-01-3090 ^{★1} MBK-01-02-3090 ^{★2}	1 set	5 - 6 (43 - 52)
DSHG-03	Soc. Hd. Cap Screw	M6 × 35 Lg.	1/4-20 UNC × 1-3/4 Lg.	4	12 - 15 (104 - 130)
(S-)DSHG-04	Soc. Hd. Cap Screw	M6 × 45 Lg. M10 × 50 Lg.	1/4-20 UNC × 1-3/4 Lg. 3/8-16 UNC × 2 Lg.	2 4	12 - 15 (104 - 130) 58 - 72 (504 - 625)
(S-)DSHG-06	Soc. Hd. Cap Screw	M12 × 60 Lg.	1/2-13 UNC × 2-1/2 Lg.	6	100 - 123 (868 - 1068)
(S-)DSHG-10	Soc. Hd. Cap Screw	M20 × 75 Lg.	3/4-10 UNC × 3 Lg.	6	473 - 585 (4106 - 5078)

- ★1. For Internal Pilot-Internal Drain.
- ★2. For External Pilot or External Drain.
- ★3. Mounting bolt kit is common to that of 01 series modular valves.
Refer to figure below for the dimensions of bolt kit.

● Stud Bolt

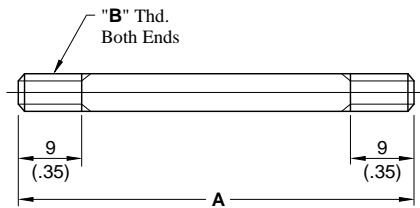

● Nut

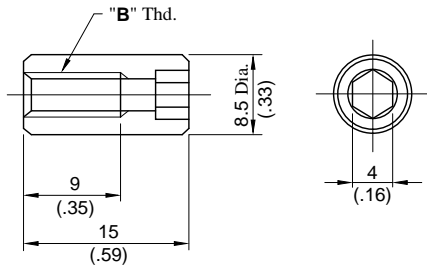

DIMENSIONS IN MILLIMETRES (INCHES)

Model Numbers	A mm (In.)	"B" Thd.
MBK-01-01-30	94 (3.70)	M5
MBK-01-02-30	134 (5.28)	
MBK-01-01-3090	94 (3.70)	No.10-24 UNC
MBK-01-02-3090	134 (5.28)	

Options

Models with Pilot Choke Adjustment

When the adjustment screw is turned clockwise, changeover speed of the main spool becomes slow. In case of the spring centred valves in particular, making slow of the returning speed of the main spool to the neutral position is possible with a C2 choke valve. These choke valves can be used in combination with the valves of spring centred, no-spring, offset, pressure centred and the valves with stroke adjustment.

Graphic Symbols (Ex.: Spring Centred)

DSHG-01,06,10

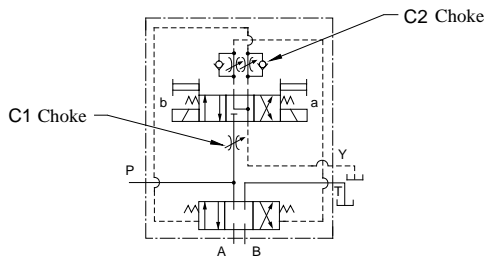

DSHG-03, 04

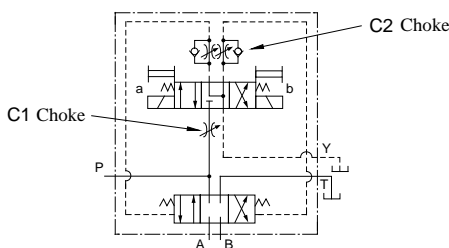

Models with Pilot Piston(P2, PA, PB)

The valves with a pilot piston can be used when the high speed changeover of the main spool is required. However, please note that in case of spring centered valves, there is no change in the returning speed of the main spool to the neutral position even with the pilot piston.

Graphic Symbols (Ex.: Spring Centred)

"P2" Models

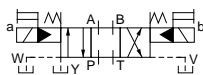

"PA" Models

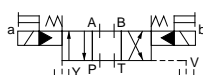

"PB" Models

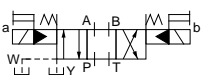

Pressure Centred Models (3H*)

The pressure centered type can be used when the returning of the main spool to the neutral position is required to be firmly.

Graphic Symbols (Ex.: External Pilot-External Drain)

(Only for 3H6, 3H60)

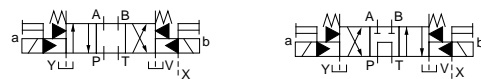

Models with Stroke Adjustment (R2, RA, RB)

When the adjustment screw is screwed in, the main spool stroke becomes short and flow rate reduces.

Graphic Symbols (Ex.: Spring Centred)

"R2" Models

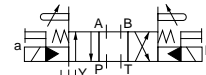

"RA" Models



"RB" Models



Additional Mass of Options

Add the mass described below to the mass of standard models on page 4, if options are required.

kg (lbs.)

Model Numbers	Model with Pilot Choke Adj.		Models with Pilot Piston		Models with Stroke Adj.	
	C1, C2	C1C2	P2	PA PB	P2	PA PB
DSHG-03	0.65(1.4)	1.3(2.9)	—	—	0.6(1.3)	0.3 (.7)
(S)-DSHG-04	0.65(1.4)	1.3(2.9)	—	—	1.0(2.2)	0.5(1.1)
(S)-DSHG-06	0.65(1.4)	1.3(2.9)	1.0(2.2)	0.5(1.1)	1.2(2.6)	0.6(1.3)
(S)-DSHG-10	0.65(1.4)	1.3(2.9)	3.6(7.9)	1.8(4.0)	3.7(8.2)	1.85(4.1)

Options on Pilot Valve

The same options to DSG-01 series valves are available. Please refer to the Catalogue No. Pub. EC-0402 for the details.

List of Standard Models and Maximum Flow

Spool Type	Three Positions				Two Positions			
	Spring Centred				Spring Centred			
	Graphic Symbol 	Maximum Flow L/min (U.S.GPM)			Graphic Symbol 	Maximum Flow L/min (U.S.GPM)		
Model Numbers	7 MPa (1020 PSI)	14 MPa (2030 PSI)	21 MPa (3050 PSI)	Model Numbers	7 MPa (1020 PSI)	14 MPa (2030 PSI)	21 MPa (3050 PSI)	
"2"	DSHG-01-3C2	40 (10.6)	40 (10.6)	40 (10.6)	DSHG-01-2B2	40 (10.6)	40 (10.6)	40 (10.6)
"3"	DSHG-01-3C3	40 (10.6)	40 (10.6)	40 (10.6)	DSHG-01-2B3	40 (10.6)	40 (10.6)	40 (10.6)
"4"	DSHG-01-3C4	40 (10.6)	40 (10.6)	40 (10.6)	DSHG-01-2B4	40 (10.6)	40 (10.6)	40 (10.6)
"40"	DSHG-01-3C40	40 (10.6)	40 (10.6)	40 (10.6)	DSHG-01-2B40	40 (10.6)	40 (10.6)	40 (10.6)
"5"	DSHG-01-3C5	40 (10.6)	40 (10.6)	40 (10.6)				
"60"	DSHG-01-3C60	40 (10.6)	40 (10.6)	40 (10.6)				
"7"	DSHG-01-3C7	40 (10.6)	40 (10.6)	40 (10.6)	DSHG-01-2B7	40 (10.6)	40 (10.6)	40 (10.6)
"9"	DSHG-01-3C9	40 (10.6)	40 (10.6)	40 (10.6)				
"10"	DSHG-01-3C10	40 (10.6)	40 (10.6)	40 (10.6)				
"11"	DSHG-01-3C11	40 (10.6)	40 (10.6)	40 (10.6)				
"12"	DSHG-01-3C12	40 (10.6)	40 (10.6)	40 (10.6)				

- Notes) 1. Max. flow shows value at pilot pressure more than 1 MPa (150 PSI)
 2. Max. flow in the table above represents the value in the flow condition of P → A → B → T (or P → B → A → T) as shown in the circuit diagram right.
 In case the valve is used in the condition that either A or B port is blocked, the maximum flow differs according to a hydraulic circuit, therefore, please consult us for details.

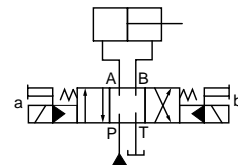

List of Standard Models and Maximum Flow

● Three Positions

Spool Type	Spring Centred				
	Graphic Symbol	Maximum Flow L/min (U.S.GPM)			
Model Numbers	7 MPa (1020 PSI)	14 MPa (2030 PSI)	25 MPa (3630 PSI)		
"2"	DSHG-03-3C2	160 (42.3)	85 (22.5)	60 (15.9)	
			160 (42.3)	95 (25.1)	
"3"	DSHG-03-3C3	160 (42.3)	160 (42.3)	160 (42.3)	
"4"	DSHG-03-3C4	160 (42.3)	85 (22.5)	60 (15.9)	
			160 (42.3)	95 (25.1)	
"40"	DSHG-03-3C40	160 (42.3)	85 (22.5)	60 (15.9)	
			160 (42.3)	95 (25.1)	
"5"	DSHG-03-3C5	160 (42.3)	85 (22.5)	60 (15.9)	
			160 (42.3)	95 (25.1)	
"60"	DSHG-03-3C60	160 (42.3)	160 (42.3)	125 (33.0)	
				160 (42.3)	
"7"	DSHG-03-3C7	160 (42.3)	85 (22.5)	60 (15.9)	
			160 (42.3)	95 (25.1)	
"9"	DSHG-03-3C9	160 (42.3)	85 (22.5)	60 (15.9)	
			160 (42.3)	95 (25.1)	
"10"	DSHG-03-3C10	160 (42.3)	85 (22.5)	60 (15.9)	
			160 (42.3)	95 (25.1)	
"11"	DSHG-03-3C11	160 (42.3)	85 (22.5)	60 (15.9)	
			160 (42.3)	95 (25.1)	
"12"	DSHG-03-3C12	160 (42.3)	85 (22.5)	60 (15.9)	
			160 (42.3)	95 (25.1)	

● Two Positions

Spool Type	No-Spring				Spring Offset			
	Graphic Symbol	Maximum Flow L/min (U.S.GPM)			Graphic Symbol	Maximum Flow L/min (U.S.GPM)		
Model Numbers	7 MPa (1020 PSI)	14 MPa (2030 PSI)	25 MPa (3630 PSI)	Model Numbers	7 MPa (1020 PSI)	14 MPa (2030 PSI)	25 MPa (3630 PSI)	
"2"	DSHG-03-2N2	160 (42.3)	160 (42.3)	85 (22.5)	DSHG-03-2B2	160 (42.3)	160 (42.3)	85 (22.5)
				160 (42.3)				160 (42.3)
"3"	DSHG-03-2N3	160 (42.3)	160 (42.3)	85 (22.5)	DSHG-03-2B3	160 (42.3)	160 (42.3)	85 (22.5)
				160 (42.3)				160 (42.3)
"4"	DSHG-03-2N4	160 (42.3)	160 (42.3)	85 (22.5)	DSHG-03-2B4	160 (42.3)	160 (42.3)	85 (22.5)
				160 (42.3)				160 (42.3)
"40"	DSHG-03-2N40	160 (42.3)	160 (42.3)	85 (22.5)	DSHG-03-2B40	160 (42.3)	160 (42.3)	85 (22.5)
				160 (42.3)				160 (42.3)
"7"	DSHG-03-2N7	160 (42.3)	160 (42.3)	85 (22.5)	DSHG-03-2B7	160 (42.3)	160 (42.3)	85 (22.5)
				160 (42.3)				160 (42.3)

Notes: 1. The relation between max. flow and pilot pressure in the table above is as shown below.

(Example)

Maximum flow rate is constant regardless of pilot pressure. → 160 (42.3)
Pilot Pressure more than 0.7 MPa (100 PSI).

160 (42.3)	85 (22.5)
	160 (42.3)

→ Pilot Pressure at 0.7 MPa (100 PSI).

→ Pilot Pressure at 1 MPa (150 PSI).

2. Max. flow in the table above represents the value in the flow condition of P → A → B → T (or P → B → A → T) as shown in the circuit diagram right.

In case the valve is used in the condition that either A or B port is blocked, the maximum flow differs according to a hydraulic circuit, therefore, please consult us for details.

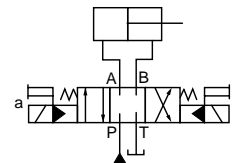

List of Standard Models and Maximum Flow

● Three Positions

Spool Type	Spring Centred				
	Graphic Symbol	Maximum Flow L/min (U.S.GPM)			
		10 MPa (1450 PSI)	16 MPa (2320 PSI)	25 MPa (3630 PSI)	31.5 MPa (4570 PSI)
Model Numbers					
"2"	DSHG-04-3C2	300 (79.3)	300 (79.3)	200 (52.8)	145 (38.3)
	(S-)DSHG-04-3C2	300 (79.3)	250 (66.1)	120 (31.7)	110 (29.1)
"3"	DSHG-04-3C3	300 (79.3)	300 (79.3)	300 (79.3)	300 (79.3)
"4"	DSHG-04-3C4	300 (79.3)	300 (79.3)	250 (66.1)	165 (43.6)
	(S-)DSHG-04-3C4	300 (79.3)	300 (79.3)	140 (37.0)	110 (29.1)
"40"	DSHG-04-3C40	300 (79.3)	300 (79.3)	200 (52.8)	145 (38.3)
	(S-)DSHG-04-3C40	300 (79.3)	250 (66.1)	120 (31.7)	110 (29.1)
"5"	DSHG-04-3C5	250 (66.1)	250 (66.1)	245 (64.7)	245 (64.7)
"6"	DSHG-04-3C6	300 (79.3)	260 (68.7)	245 (64.7)	235 (62.1)
"60"	DSHG-04-3C60	300 (79.3)	300 (79.3)	300 (79.3)	300 (79.3)
	(S-)DSHG-04-3C60	300 (79.3)	300 (79.3)	300 (79.3)	300 (79.3)
"7"	DSHG-04-3C7	300 (79.3)	300 (79.3)	200 (52.8)	145 (38.3)
"9"	DSHG-04-3C9	300 (79.3)	300 (79.3)	280 (74.0)	250 (66.1)
"10"	DSHG-04-3C10	300 (79.3)	300 (79.3)	200 (52.8)	150 (39.6)
	(S-)DSHG-04-3C10	300 (79.3)	250 (66.1)	120 (31.7)	110 (29.1)
"11"	DSHG-04-3C11	300 (79.3)	260 (68.7)	160 (42.3)	140 (37.0)
"12"	DSHG-04-3C12	300 (79.3)	280 (74.0)	170 (44.9)	135 (35.7)
	(S-)DSHG-04-3C12	300 (79.3)	250 (66.1)	120 (31.7)	110 (29.1)

● Two Positions

Spool Type	No-Spring					Spring Offset				
	Graphic Symbol	Maximum Flow L/min (U.S.GPM)				Graphic Symbol	Maximum Flow L/min (U.S.GPM)			
		10 MPa (1450 PSI)	16 MPa (2320 PSI)	25 MPa (3630 PSI)	31.5 MPa (4570 PSI)		10 MPa (1450 PSI)	16 MPa (2320 PSI)	25 MPa (3630 PSI)	31.5 MPa (4570 PSI)
Model Numbers					Model Numbers					
"2"	(S-)DSHG-04-2N2	300 (79.3)	300 (79.3)	300 (79.3)	300 (79.3)	(S-)DSHG-04-2B2	300 (79.3)	300 (79.3)	300 (79.3)	300 (79.3)
"3"	DSHG-04-2N3	300 (79.3)	300 (79.3)	300 (79.3)	300 (79.3)	DSHG-04-2B3	300 (79.3)	300 (79.3)	300 (79.3)	300 (79.3)
"4"	(S-)DSHG-04-2N4	300 (79.3)	300 (79.3)	300 (79.3)	300 (79.3)	(S-)DSHG-04-2B4	300 (79.3)	300 (79.3)	300 (79.3)	300 (79.3)
"40"	(S-)DSHG-04-2N40	300 (79.3)	300 (79.3)	300 (79.3)	300 (79.3)	(S-)DSHG-04-2B40	300 (79.3)	300 (79.3)	300 (79.3)	300 (79.3)
"7"	DSHG-04-2N7	300 (79.3)	300 (79.3)	300 (79.3)	300 (79.3)	DSHG-04-2B7	300 (79.3)	300 (79.3)	300 (79.3)	300 (79.3)

Notes: 1. Max flow described above shown value at pilot pressure more than 0.8 MPa (120 PSI).

2. Max. flow in the table above represents the value in the flow condition of P → A → B → T (or P → B → A → T) as shown in the circuit diagram right.
In case the valve is used in the condition that either A or B port is blocked, the maximum flow differs according to a hydraulic circuit, therefore, please consult us for details.

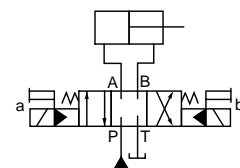

List of Standard Models and Maximum Flow

● Three Positions

Spool Type	Spring Centred					Pressure Centred				
	Graphic Symbol	Maximum Flow L/min (U.S.GPM)				Graphic Symbol	Maximum Flow L/min (U.S.GPM)			
		10 MPa (1450 PSI)	16 MPa (2320 PSI)	25 MPa (3630 PSI)	31.5 MPa (4570 PSI)		10 MPa (1450 PSI)	16 MPa (2320 PSI)	25 MPa (3630 PSI)	31.5 MPa (4570 PSI)
Model Numbers	10 MPa (1450 PSI)	16 MPa (2320 PSI)	25 MPa (3630 PSI)	31.5 MPa (4570 PSI)	Model Numbers	10 MPa (1450 PSI)	16 MPa (2320 PSI)	25 MPa (3630 PSI)	31.5 MPa (4570 PSI)	
"2"	(S-)DSHG-06-3C2	500 (132)	500 (132)	410 (108) 500 (132)	310 (81.9) 500 (132)	(S-)DSHG-06-3H2	500 (132)	500 (132)	500 (132)	420 (111) 500 (132)
"3"	DSHG-06-3C3	500 (132)	500 (132)	460 (122)	370 (97.8)	DSHG-06-3H3	500 (132)	500 (132)	500 (132)	500 (132)
"4"	(S-)DSHG-06-3C4	500 (132)	500 (132)	410 (108) 500 (132)	310 (81.9) 500 (132)	(S-)DSHG-06-3H4	500 (132)	500 (132)	500 (132)	420 (111) 500 (132)
"40"	(S-)DSHG-06-3C40	500 (132)	500 (132)	410 (108) 500 (132)	310 (81.9) 500 (132)	(S-)DSHG-06-3H40	500 (132)	500 (132)	500 (132)	420 (111) 500 (132)
"5"	DSHG-06-3C5	500 (132)	500 (132)	425 (112)	350 (92.5)	DSHG-06-3H5	500 (132)	500 (132)	500 (132)	470 (124) 500 (132)
"6"	DSHG-06-3C6	475 (125)	390 (103)	300 (79.3)	230 (60.8)	DSHG-06-3H6	500 (132)	500 (132)	500 (132)	420 (111) 500 (132)
"60"	(S-)DSHG-06-3C60	475 (125)	420 (111)	340 (89.8)	280 (74.0)	(S-)DSHG-06-3H60	500 (132)	500 (132)	500 (132)	420 (111) 500 (132)
"7"	DSHG-06-3C7	500 (132)	500 (132)	450 (119)	360 (95.1)	DSHG-06-3H7	500 (132)	500 (132)	500 (132)	500 (132)
"9"	DSHG-06-3C9	500 (132)	500 (132)	450 (119) 500 (132)	360 (95.1) 500 (132)	DSHG-06-3H9	500 (132)	500 (132)	500 (132)	500 (132)
"10"	(S-)DSHG-06-3C10	500 (132)	500 (132)	410 (108) 500 (132)	310 (81.9) 500 (132)	(S-)DSHG-06-3H10	500 (132)	500 (132)	500 (132)	460 (122) 500 (132)
"11"	DSHG-06-3C11	500 (132)	500 (132)	410 (108) 500 (132)	310 (81.9) 500 (132)	DSHG-06-3H11	500 (132)	500 (132)	500 (132)	460 (122) 500 (132)
"12"	(S-)DSHG-06-3C12	500 (132)	500 (132)	410 (108) 500 (132)	310 (81.9) 500 (132)	(S-)DSHG-06-3H12	500 (132)	500 (132)	500 (132)	460 (122) 500 (132)

● Two Positions

Spool Type	No-Spring					Spring Offset				
	Graphic Symbol	Maximum Flow L/min (U.S.GPM)				Graphic Symbol	Maximum Flow L/min (U.S.GPM)			
		10 MPa (1450 PSI)	16 MPa (2320 PSI)	25 MPa (3630 PSI)	31.5 MPa (4570 PSI)		10 MPa (1450 PSI)	16 MPa (2320 PSI)	25 MPa (3630 PSI)	31.5 MPa (4570 PSI)
Model Numbers	10 MPa (1450 PSI)	16 MPa (2320 PSI)	25 MPa (3630 PSI)	31.5 MPa (4570 PSI)	Model Numbers	10 MPa (1450 PSI)	16 MPa (2320 PSI)	25 MPa (3630 PSI)	31.5 MPa (4570 PSI)	
"2"	(S-)DSHG-06-2N2	500 (132)	500 (132)	500 (132)	500 (132)	(S-)DSHG-06-2B2	500 (132)	500 (132)	500 (132)	500 (132)
"3"	DSHG-06-2N3	500 (132)	500 (132)	500 (132)	500 (132)	DSHG-06-2B3	500 (132)	500 (132)	500 (132)	500 (132)
"4"	(S-)DSHG-06-2N4	500 (132)	500 (132)	500 (132)	500 (132)	(S-)DSHG-06-2B4	500 (132)	500 (132)	500 (132)	500 (132)
"40"	(S-)DSHG-06-2N40	500 (132)	500 (132)	500 (132)	500 (132)	(S-)DSHG-06-2B40	500 (132)	500 (132)	500 (132)	500 (132)
"7"	DSHG-06-2N7	500 (132)	500 (132)	500 (132)	500 (132)	DSHG-06-2B7	500 (132)	500 (132)	500 (132)	500 (132)

Notes: 1. The relation between max. flow and pilot pressure in the table above is as shown below.

(Example)

Maximum flow rate is constant regardless of pilot pressure. → 500 (132)
 Pilot Pressure more than 0.8 MPa (120 PSI).
 In case pressure centred models, pilot pressure is more than 1 MPa (150 PSI).

500 (132)	410 (108)
500 (132)	500 (132)

→ Pilot Pressure at 0.8 MPa (120 PSI).
 In case pressure centred models, pilot pressure is more than 1 MPa (150 PSI)

→ Pilot Pressure at 1.5 MPa (220 PSI).

2. Max. flow in the table above represents the value in the flow condition of P → A → B → T (or P → B → A → T) as shown in the circuit diagram right.
 In case the valve is used in the condition that either A or B port is blocked, the maximum flow differs according to a hydraulic circuit, therefore, please consult us for details.

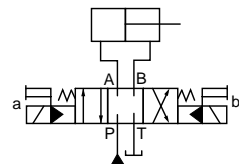

List of Standard Models and Maximum Flow

● Three Positions

Spool Type	Spring Centred					Pressure Centred				
	Graphic Symbol	Maximum Flow L/min (U.S.GPM)				Graphic Symbol	Maximum Flow L/min (U.S.GPM)			
	Model Numbers	10 MPa (1450 PSI)	16 MPa (2320 PSI)	25 MPa (3630 PSI)	31.5 MPa (4570 PSI)	Model Numbers	10 MPa (1450 PSI)	16 MPa (2320 PSI)	25 MPa (3630 PSI)	31.5 MPa (4570 PSI)
"2"	(S-)DSHG-10-3C2	1100 (291)	1100 (291)	950 (251) 1100 (291)	750 (198) 1100 (291)	(S-)DSHG-10-3H2	1100 (291)	1100 (291)	1100 (291)	970 (256) 1100 (291)
"3"	DSHG-10-3C3	1100 (291)	1100 (291)	1060 (280)	895 (236)	DSHG-10-3H3	1100 (291)	1100 (291)	1100 (291)	1050 (277) 1100 (291)
"4"	(S-)DSHG-10-3C4	1100 (291)	1100 (291)	950 (251) 1100 (291)	750 (198) 1100 (291)	(S-)DSHG-10-3H4	1100 (291)	1100 (291)	1100 (291)	970 (256) 1100 (291)
"40"	(S-)DSHG-10-3C40	1100 (291)	1100 (291)	950 (251) 1100 (291)	750 (198) 1100 (291)	(S-)DSHG-10-3H40	1100 (291)	1100 (291)	1100 (291)	970 (256) 1100 (291)
"5"	DSHG-10-3C5	1100 (291)	1100 (291)	980 (259)	850 (225)	DSHG-10-3H5	1100 (291)	1100 (291)	1100 (291)	1000 (264) 1100 (291)
"6"	DSHG-10-3C6	1050 (277)	880 (232)	700 (185)	570 (151)	DSHG-10-3H6	1100 (291)	1100 (291)	1100 (291)	970 (256) 1100 (291)
"60"	(S-)DSHG-10-3C60	1050 (277)	940 (248)	785 (207)	680 (180)	(S-)DSHG-10-3H60	1100 (291)	1100 (291)	1100 (291)	970 (256) 1100 (291)
"7"	DSHG-10-3C7	1100 (291)	1100 (291)	1040 (275) 1100 (291)	870 (230) 1100 (291)	DSHG-10-3H7	1100 (291)	1100 (291)	1100 (291)	1100 (291)
"9"	DSHG-10-3C9	1100 (291)	1100 (291)	1040 (275)	870 (230)	DSHG-10-3H9	1100 (291)	1100 (291)	1100 (291)	1100 (291)
"10"	(S-)DSHG-10-3C10	1100 (291)	1100 (291)	950 (251) 1100 (291)	750 (198) 1100 (291)	(S-)DSHG-10-3H10	1100 (291)	1100 (291)	1100 (291)	1060 (280) 1100 (291)
"11"	DSHG-10-3C11	1100 (291)	1100 (291)	950 (251) 1100 (291)	750 (198) 1100 (291)	DSHG-10-3H11	1100 (291)	1100 (291)	1100 (291)	1060 (280) 1100 (291)
"12"	(S-)DSHG-10-3C12	1100 (291)	1100 (291)	950 (251) 1100 (291)	750 (198) 1100 (291)	(S-)DSHG-10-3H12	1100 (291)	1100 (291)	1100 (291)	1060 (280) 1100 (291)

● Two Positions

Spool Type	No-Spring					Spring Offset				
	Graphic Symbol	Maximum Flow L/min (U.S.GPM)				Graphic Symbol	Maximum Flow L/min (U.S.GPM)			
	Model Numbers	10 MPa (1450 PSI)	16 MPa (2320 PSI)	25 MPa (3630 PSI)	31.5 MPa (4570 PSI)	Model Numbers	10 MPa (1450 PSI)	16 MPa (2320 PSI)	25 MPa (3630 PSI)	31.5 MPa (4570 PSI)
"2"	(S-)DSHG-10-2N2	1100 (291)	1100 (291)	1100 (291)	1100 (291)	(S-)DSHG-10-2B2	1100 (291)	1100 (291)	1100 (291)	1100 (291)
"3"	DSHG-10-2N3	1100 (291)	1100 (291)	1100 (291)	1100 (291)	DSHG-10-2B3	1100 (291)	1100 (291)	1100 (291)	1100 (291)
"4"	(S-)DSHG-10-2N4	1100 (291)	1100 (291)	1100 (291)	1100 (291)	(S-)DSHG-10-2B4	1100 (291)	1100 (291)	1100 (291)	1100 (291)
"40"	(S-)DSHG-10-2N40	1100 (291)	1100 (291)	1100 (291)	1100 (291)	(S-)DSHG-10-2B40	1100 (291)	1100 (291)	1100 (291)	1100 (291)
"7"	DSHG-10-2N7	1100 (291)	1100 (291)	1100 (291)	1100 (291)	DSHG-10-2B7	1100 (291)	1100 (291)	1100 (291)	1100 (291)

Notes) 1. The relation between max. flow and pilot pressure in the table above is as shown below.

(Example)

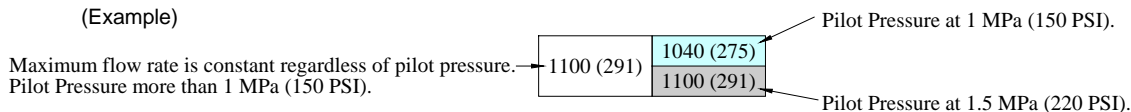

2. Max. flow in the table above represents the value in the flow condition of P → A → B → T (or P → B → A → T) as shown in the circuit diagram right.
In case the valve is used in the condition that either A or B port is blocked, the maximum flow differs according to a hydraulic circuit, therefore, please consult us for details.

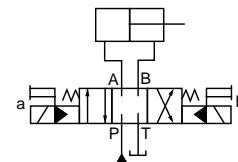

■ Reverse Mounting of Solenoid.

In spring offset type, it is a standard configuration that the solenoid is mounted onto the valve in the SOL b position (side). However, in this particular spool-spring arrangement, the mounting of the solenoid onto the valve in the reverse position - SOL a side - is also available. The graphic symbol for this reverse mounting is as shown below. As for the valve type 2B*A and 2B*B, please refer to the explanation under the heading of "Valves Using Neutral Position and Side Position" given below.

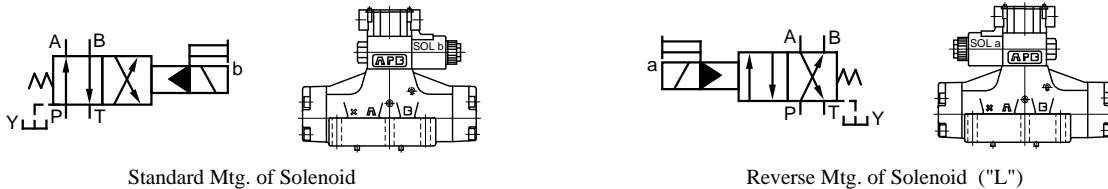

■ Valves Using Neutral Position and Side Position. (Special Two position Valve)

Besides the use of the standard 2-position valves aforementioned in the "List of Standard Models and Maximum Flow", the 3-position valves also can be used as the 2-position valves using the two of their three positions. In this case, there are two kinds of the valve available. One is the valve using the neutral position and SOL a position (2B*A) and another is the valve using the neutral position and SOL b position (2B*B).

(Example) In case of Spool Type "2"

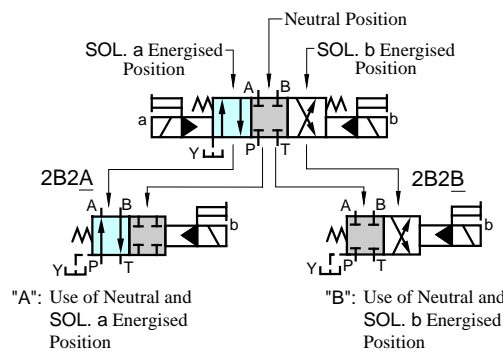

"A": Use of Neutral and SOL. a Energised Position

"B": Use of Neutral and SOL. b Energised Position

Model Numbers	Graphic Symbols		Model Numbers	Graphic Symbols		Model Numbers	Graphic Symbols	
	Standard Mtg.	Reverse Mtg. Type		Standard Mtg.	Reverse Mtg. Type		Standard Mtg.	Reverse Mtg. Type
04 DSHG-06-2B*A 10			04 DSHG-06-2B*B 10			04 DSHG-06-2N*A 10		
(S-)DSHG-*2B2A			(S-)DSHG-*2B2B			(S-)DSHG-*2N2A		
DSHG-*2B3A			DSHG-*2B3B			DSHG-*2N3A		
(S-)DSHG-*2B4A			(S-)DSHG-*2B4B			(S-)DSHG-*2N4A		
(S-)DSHG-*2B40A			(S-)DSHG-*2B40B			(S-)DSHG-*2N40A		
DSHG-*2B5A			DSHG-*2B5B			DSHG-*2N5A		
DSHG-*2B6A			DSHG-*2B6B			DSHG-*2N6A		
(S-)DSHG-*2B60A			(S-)DSHG-*2B60B			(S-)DSHG-*2N60A		
DSHG-*2B7A			DSHG-*2B7B			DSHG-*2N7A		
DSHG-*2B9A			DSHG-*2B9B			DSHG-*2N9A		
(S-)DSHG-*2B10A			(S-)DSHG-*2B10B			(S-)DSHG-*2N10A		
DSHG-*2B11A			DSHG-*2B11B			DSHG-*2N11A		
(S-)DSHG-*2B12A			(S-)DSHG-*2B12B			(S-)DSHG-*2N12A		

Pressure Drop

Pressure drop curves based on viscosity of 35 mm²/s (164 SSU) and specific gravity of 0.850.

● DSHG-01

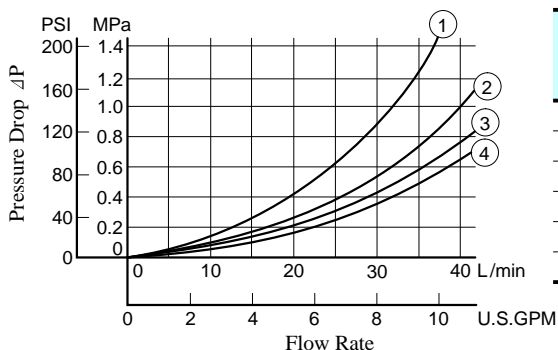

● DSHG-01

Spool Type	Pressure Drop Curve Numbers					Spool Type	Pressure Drop Curve Numbers				
	P→A	B→T	P→B	A→T	P→T		P→A	B→T	P→B	A→T	P→T
2	③	②	③	②	—	7	③	②	③	②	—
3	④	②	④	②	②	9	④	②	④	②	—
4	③	②	③	②	—	10	③	②	③	②	—
40	③	②	③	②	—	11	③	②	③	②	—
5	③	②	③	②	①	12	③	②	③	②	—
60	③	②	③	②	①						

● DSHG-03

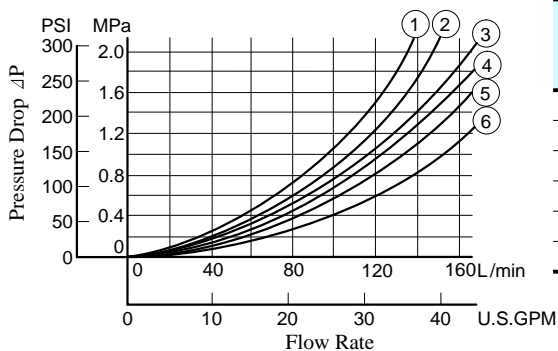

● DSHG-03

Spool Type	Pressure Drop Curve Numbers					Spool Type	Pressure Drop Curve Numbers				
	P→A	B→T	P→B	A→T	P→T		P→A	B→T	P→B	A→T	P→T
2	③	③	④	④	—	7	③	③	④	④	—
3	⑤	⑤	⑤	⑥	④	9	⑥	③	⑥	④	—
4	③	⑤	④	⑥	—	10	③	⑤	④	④	—
40	③	③	④	④	—	11	⑥	③	④	④	—
5	⑥	③	④	⑥	②	12	③	③	④	⑥	—
60	③	③	④	④	①						

● DSHG-04, S-DSHG-04

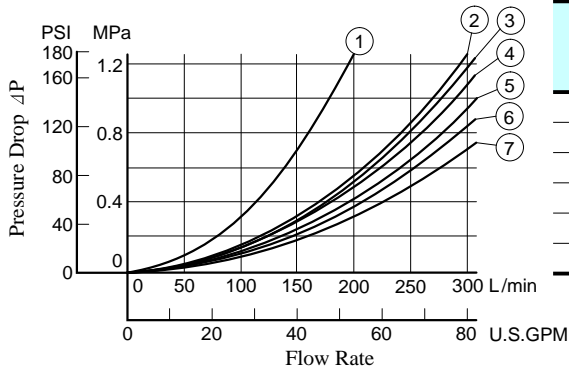

● DSHG-04

Spool Type	Pressure Drop Curve Numbers					Spool Type	Pressure Drop Curve Numbers				
	P→A	B→T	P→B	A→T	P→T		P→A	B→T	P→B	A→T	P→T
2	⑤	④	⑤	⑥	—	60	⑦	⑤	⑦	⑦	②
3	⑤	③	⑤	⑤	⑦	7	⑤	④	⑤	⑥	—
4	⑤	③	⑤	⑤	—	9	⑤	④	⑤	⑥	—
40	⑤	④	⑤	⑥	—	10	⑤	②	⑤	⑥	—
5	⑦	④	⑤	⑤	⑤	11	⑥	④	⑤	⑥	—
6	⑤	③	⑤	⑥	①	12	⑤	④	⑤	⑤	—

● S-DSHG-04

Spool Type	Pressure Drop Curve Numbers					Spool Type	Pressure Drop Curve Numbers				
	P→A	B→T	P→B	A→T	P→T		P→A	B→T	P→B	A→T	P→T
2	②	②	②	④	—	60	⑥	④	⑥	⑦	②
4	②	③	②	⑤	—	10	②	②	②	④	—
40	②	④	②	⑥	—	12	②	②	②	⑤	—



Pressure Drop

DSHG-06, S-DSHG-06

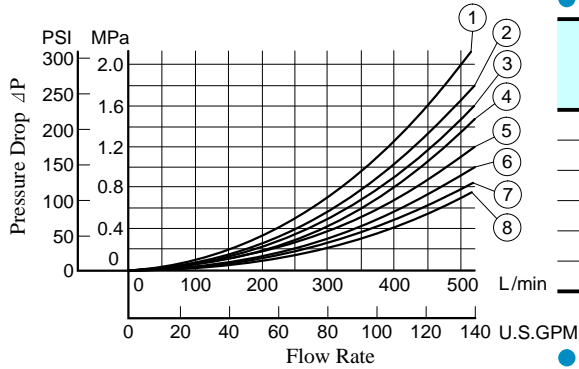

DSHG-06

Spool Type	Pressure Drop Curve Numbers					Spool Type	Pressure Drop Curve Numbers				
	P→A	B→T	P→B	A→T	P→T		P→A	B→T	P→B	A→T	P→T
2	(8)	(5)	(8)	(7)	—	60	(6)	(5)	(6)	(7)	(1)
3	(6)	(4)	(6)	(7)	(4)	7	(6)	(4)	(6)	(7)	—
4	(8)	(5)	(8)	(7)	—	9	(6)	(5)	(6)	(7)	—
40	(8)	(5)	(8)	(7)	—	10	(8)	(5)	(8)	(7)	—
5	(8)	(4)	(5)	(7)	(1)	11	(8)	(4)	(5)	(7)	—
6	(5)	(3)	(5)	(4)	(1)	12	(8)	(5)	(8)	(7)	—

S-DSHG-06

Spool Type	Pressure Drop Curve Numbers					Spool Type	Pressure Drop Curve Numbers				
	P→A	B→T	P→B	A→T	P→T		P→A	B→T	P→B	A→T	P→T
2	(6)	(1)	(6)	(2)	—	60	(6)	(2)	(6)	(3)	(1)
4	(6)	(2)	(6)	(2)	—	10	(8)	(5)	(8)	(7)	—
40	(8)	(5)	(8)	(7)	—	12	(8)	(5)	(8)	(7)	—

DSHG-10, S-DSHG-10

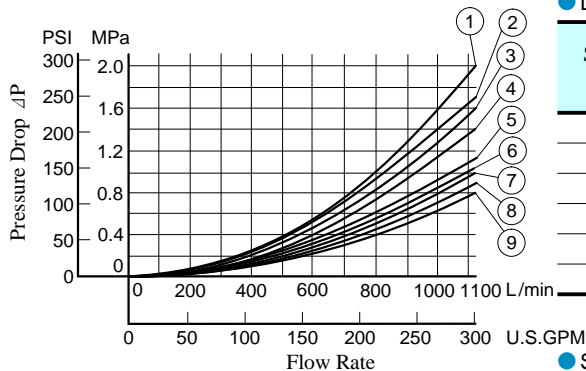

DSHG-10

Spool Type	Pressure Drop Curve Numbers					Spool Type	Pressure Drop Curve Numbers				
	P→A	B→T	P→B	A→T	P→T		P→A	B→T	P→B	A→T	P→T
2	(9)	(6)	(9)	(8)	—	60	(8)	(5)	(8)	(5)	(3)
3	(7)	(6)	(7)	(7)	(5)	7	(7)	(6)	(7)	(7)	—
4	(9)	(6)	(9)	(6)	—	9	(7)	(6)	(7)	(8)	—
40	(9)	(6)	(9)	(8)	—	10	(9)	(5)	(9)	(8)	—
5	(9)	(6)	(8)	(6)	(1)	11	(9)	(6)	(8)	(7)	—
6	(5)	(3)	(5)	(2)	(2)	12	(9)	(7)	(9)	(6)	—

S-DSHG-10

Spool Type	Pressure Drop Curve Numbers					Spool Type	Pressure Drop Curve Numbers				
	P→A	B→T	P→B	A→T	P→T		P→A	B→T	P→B	A→T	P→T
2	(8)	(3)	(8)	(4)	—	60	(8)	(4)	(8)	(4)	(2)
4	(8)	(5)	(8)	(6)	—	10	(9)	(5)	(9)	(8)	—
40	(9)	(6)	(9)	(8)	—	12	(9)	(7)	(9)	(6)	—

For any other viscosity, multiply the factors in the table below.

Viscosity	mm ² /s	15	20	30	40	50	60	70	80	90	100
	SSU		77	98	141	186	232	278	324	371	417
Factor		0.81	0.87	0.96	1.03	1.09	1.14	1.19	1.23	1.27	1.30

For any other specific gravity (G'), the pressure drop (ΔP') may be obtained from the formula right.

$$\Delta P' = \Delta P(G'/0.850)$$

Typical Changeover Time

Changeover time varies according to oil viscosity, spool type and hydraulic circuit.

● **Test Conditions**

- Coil Type : D*(Models with DC solenoids)
- Voltage : Rated Voltage
- Oil Viscosity : 35 mm²/s (164 SSU)

● **DSHG-04**

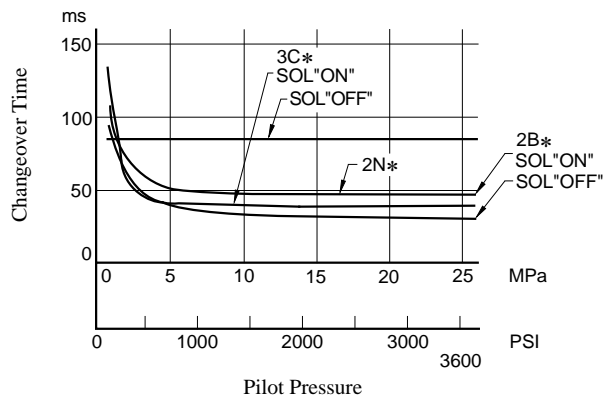

● **DSHG-10**

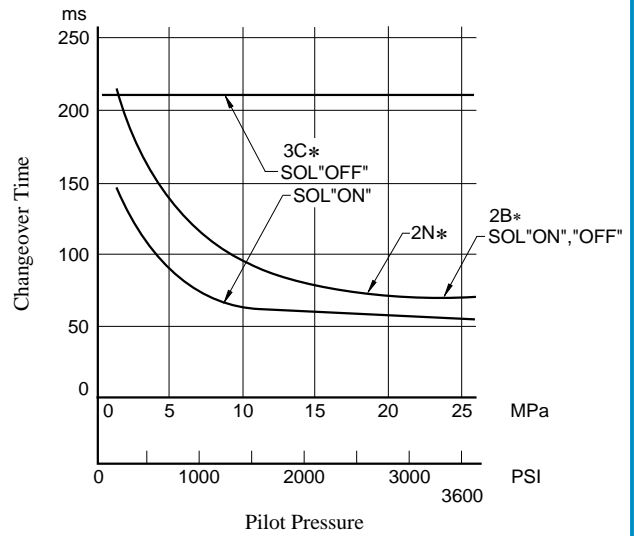

● **DSHG-06**

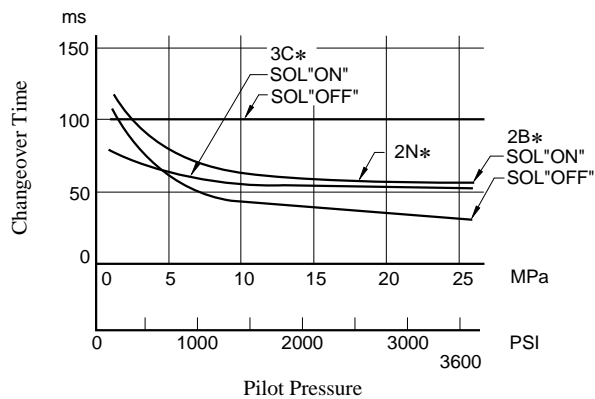

Installation Drawing

Terminal Box type: DSHG-01-***-13/1390

Mounting surface: ISO 4401-AB-03-4-A

● **Internal Pilot - Internal Drain**

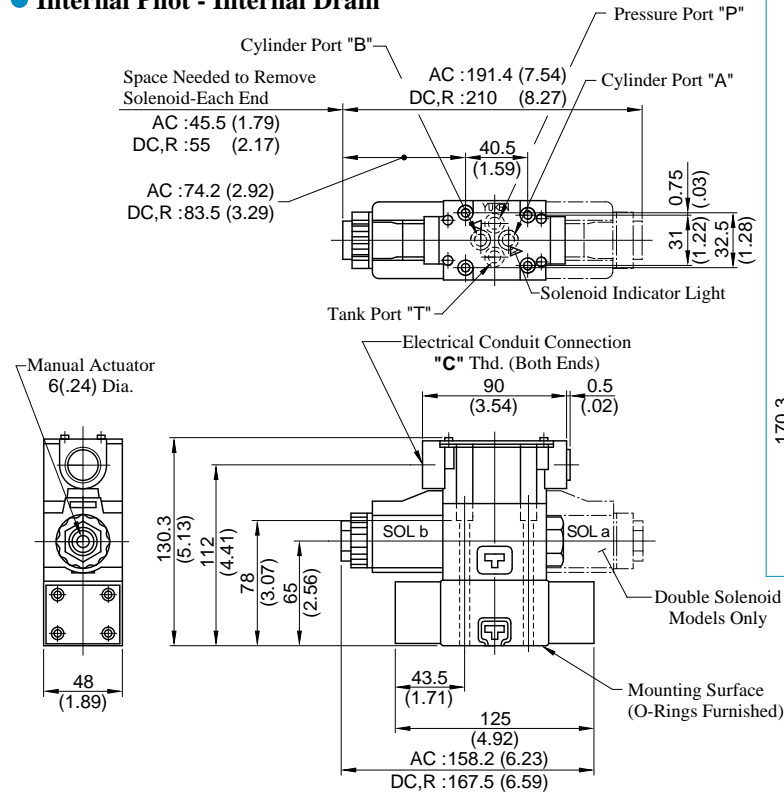

- External Pilot - External Drain
- External Pilot - Internal Drain
- Internal Pilot - External Drain

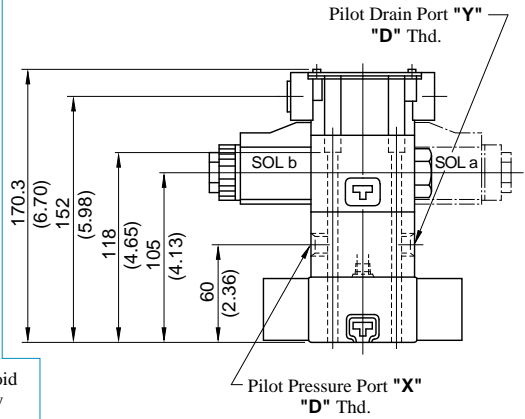

● For other dimensions, refer to "Internal Pilot Internal Drain".

Model Numbers	"C" Thd.	"D" Thd.
DSHG-01-***-13	G 1/2	Rc 1/4
DSHG-01-***-1390	1/2 NPT	1/4 NPT

DIMENSIONS IN
MILLIMETRES (INCHES)

■ **Sub-plates**

DSGM-01*-30/3080/3090

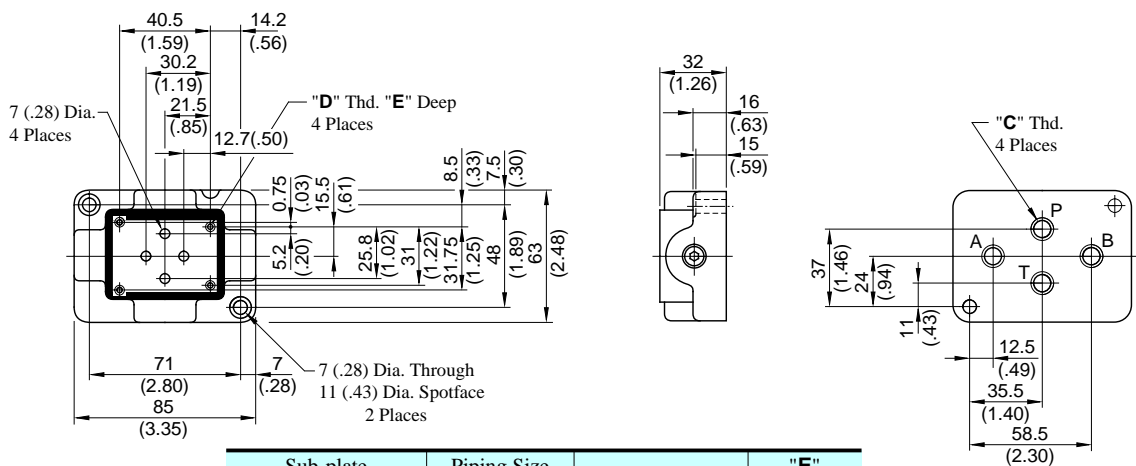

Sub-plate Model Numbers	Piping Size "C" Thd.	"D" Thd.	"E" mm (IN.)
DSGM-01-30	Rc 1/8	M5	10 (.39)
DSGM-01-3080	1/8 BSP.F		
DSGM-01-3090	1/8 NPT	No. 10-24 UNC	12 (.47)
DSGM-01X-30	Rc 1/4	M5	10 (.39)
DSGM-01X-3080	1/4 BSP.F		
DSGM-01X-3090	1/4 NPT	No. 10-24 UNC	12 (.47)
DSGM-01Y-30	Rc 3/8	M5	10 (.39)
DSGM-01Y-3090	3/8 NPT		

■ Plug-in Connector Type: DSHG-01-***-N₁-13/1380/1390

● Internal Pilot-Internal Drain

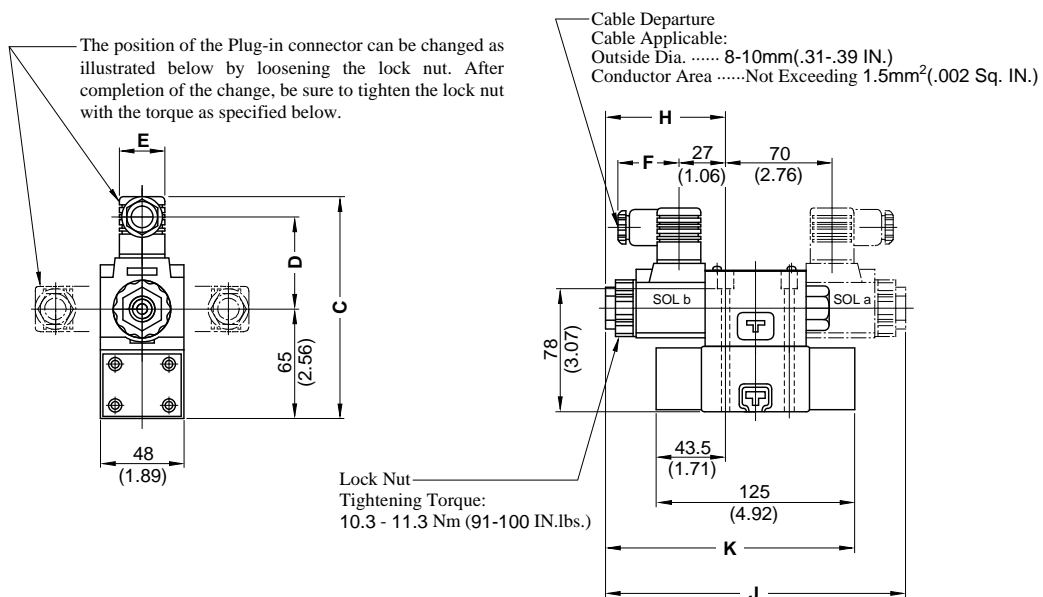

- External Pilot-External Drain
- External Pilot-Internal Drain
- Internal Pilot-External Drain

DIMENSIONS IN MILLIMETRES (INCHES)

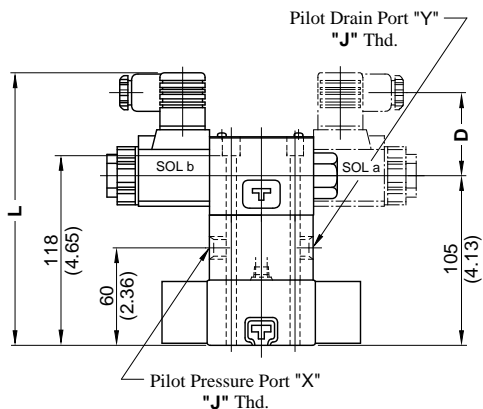

Model Numbers	"J" Thd.
DSHG-01-***-N*-13	Rc 1/4
DSHG-01-***-N*-1380	1/4 BSP.F
DSHG-01-***-N*-1390	1/4 NPT

Model Numbers	Dimensions mm (Inches)							
	C	D	E	F	H	J	K	L
DSHG-01-***-A*-N/N1	130 (5.12)	53 (2.09)	27.5 (1.08)	39 (1.54)	74.2 (2.92)	191.4 (7.54)	158.2 (6.23)	170 (6.69)
DSHG-01-***-D*-N/N1	141 (5.55)	64 (2.52)	27.5 (1.08)	39 (1.54)	83.5 (3.29)	210 (8.27)	167.5 (6.59)	181 (7.13)
DSHG-01-***-R*-N	144 (5.67)	57.2 (2.25)	34 (1.34)	53 (2.09)				184 (7.24)

● For other dimensions, refer to "Terminal Box Type".



Installation Drawing

Terminal Box Type: DSHG-03-***-13/1390

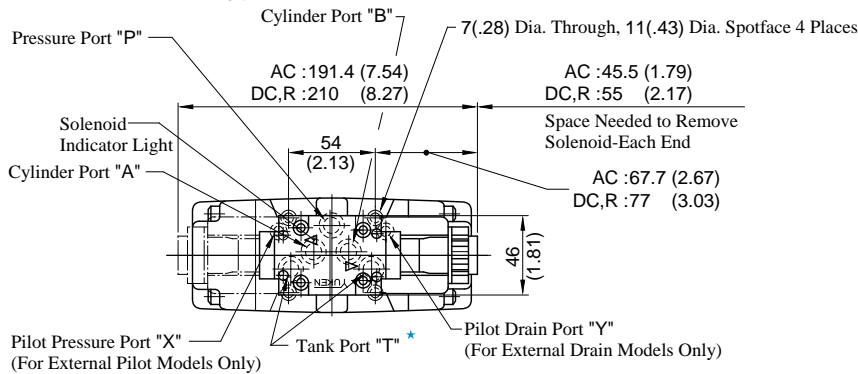

Mounting surface: ISO 4401-AC-05-4-A
(The pilot and drain ports in accordance with the ISO original draft)

Model Numbers	"C" Thd.
DSHG-03-***-13	G 1/2
DSHG-03-***-1390	1/2 NPT

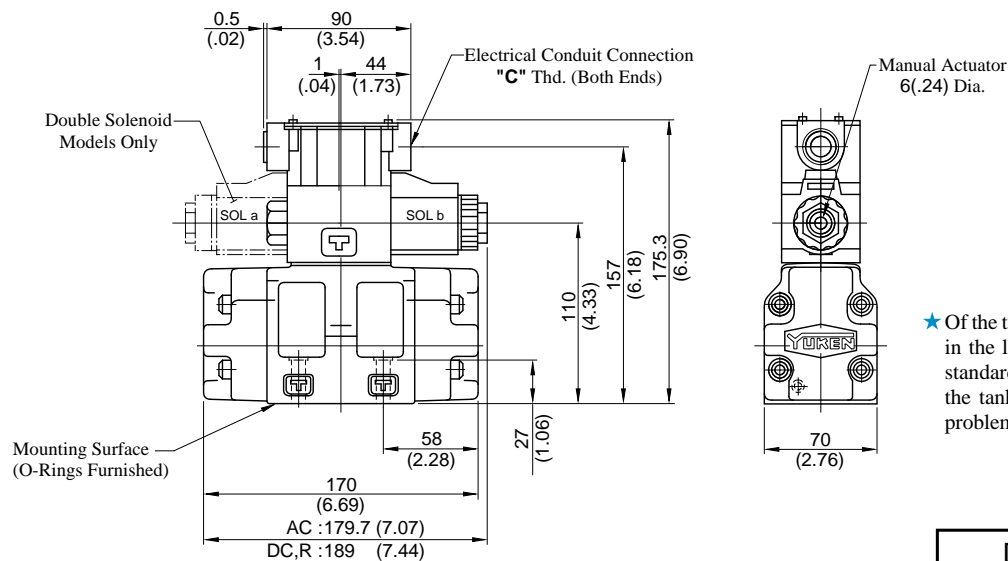

★ Of the two of tank port "T", the tank port in the left side is normally used in our standard sub-plate, though, either side of the tank port "T" can be used without problem.

**DIMENSIONS IN
MILLIMETRES (INCHES)**

Plug-in Connector Type: DSHG-03-***-N_{N1}-13/1390

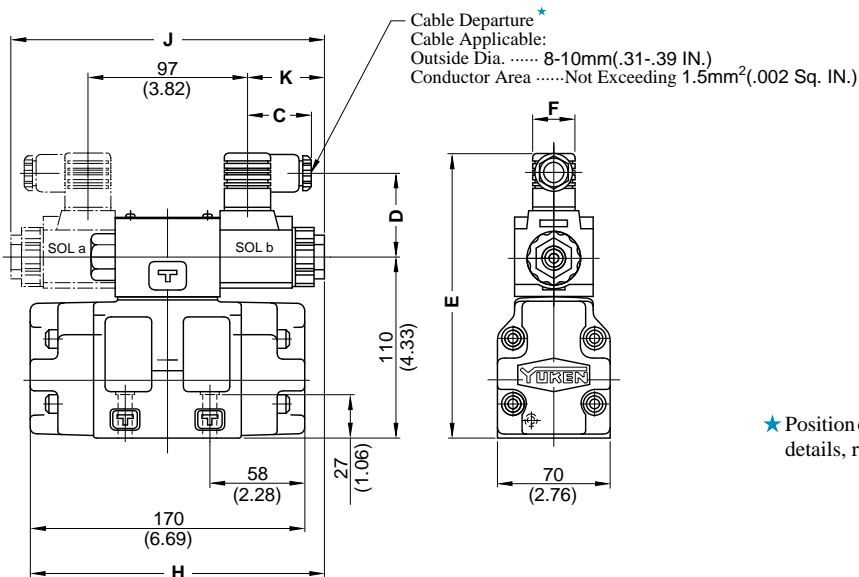

★ Position of cable departure can be changed. For details, refer to DSHG-01 valve on page 19.

Model Numbers	Dimensions mm (Inches)						
	C	D	E	F	H	J	K
DSHG-03-***-A*-N/N1	39 (1.54)	53 (2.09)	175 (6.89)	27.5 (1.08)	179.7 (7.07)	191.4 (7.54)	47.2 (1.86)
DSHG-03-***-D*-N/N1	39 (1.54)	64 (2.52)	186 (7.32)	27.5 (1.08)	189 (7.44)	210 (8.27)	56.5 (2.22)
DSHG-03-***-R*-N	53 (2.09)	57.2 (2.25)	189 (7.44)	34 (1.34)			

• For other dimensions, refer to "Terminal Box Type".

Installation Drawing

Terminal Box Type: (S-)DSHG-04-***-51/5190

Mounting surface:
ISO 4401-AD-07-4-A

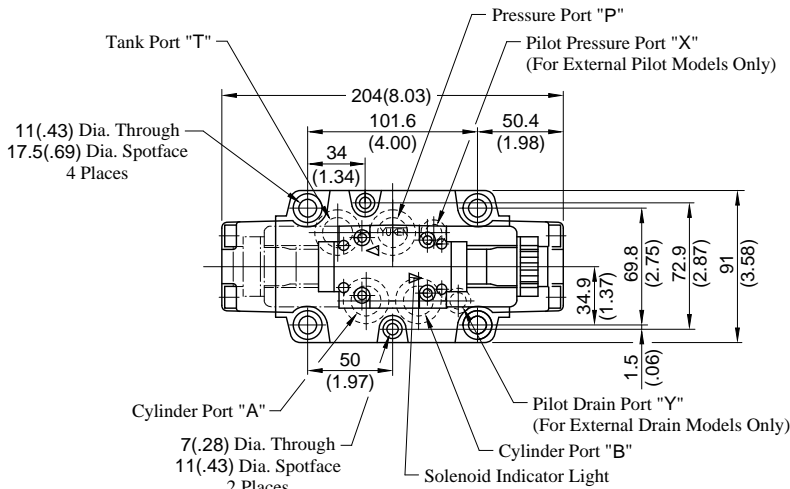

Model Numbers	"C" Thd.
(S-)DSHG-04-***-51	G 1/2
(S-)DSHG-04-***-5190	1/2 NPT

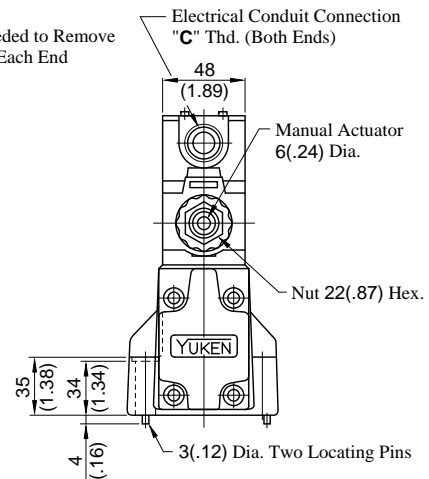
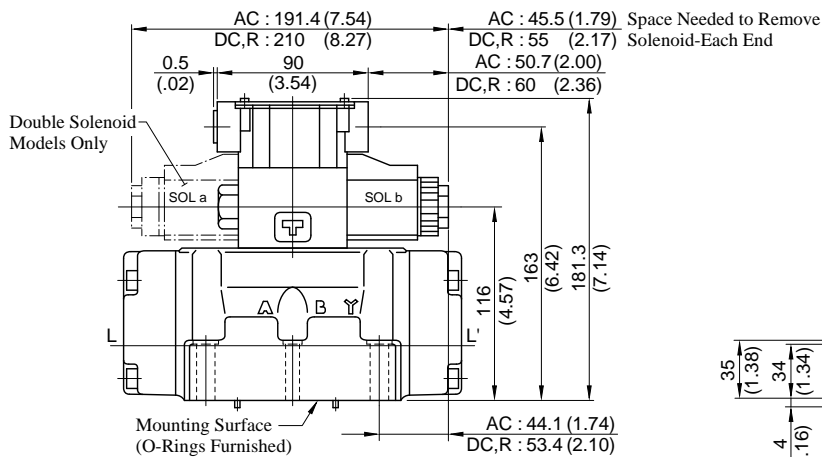

DIMENSIONS IN
MILLIMETRES (INCHES)

Plug-in Connector Type: (S-)DSHG-04-***-N₁-51/5190

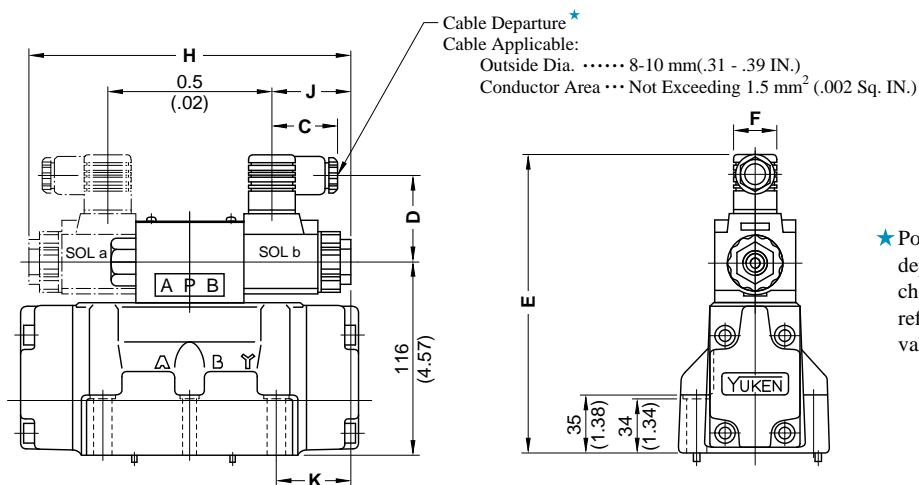

★ Position of cable departure can be changed. For details, refer to DSHG-01 valve on page 19.

Model Numbers	Dimensions mm (Inches)						
	C	D	E	F	H	J	K
(S-)DSHG-04-***-A*-N/N1	39(1.54)	53(2.09)	181(7.13)	27.5(1.08)	191.4(7.54)	47.2(1.86)	44.1(1.74)
(S-)DSHG-04-***-D*-N/N1	39(1.54)	64(2.52)	192(7.56)	27.5(1.08)	210(8.27)	56.5(2.22)	53.4(2.10)
(S-)DSHG-04-***-R*-N	53(2.09)	57.2(2.25)	195(7.68)	34(1.34)	210(8.27)	56.5(2.22)	53.4(2.10)

• For other dimensions, refer to "Terminal Box Type".

Installation Drawing

Terminal Box Type: (S-)DSHG-06-***-52/5290

Mounting surface:
ISO 4401-AE-08-4-A

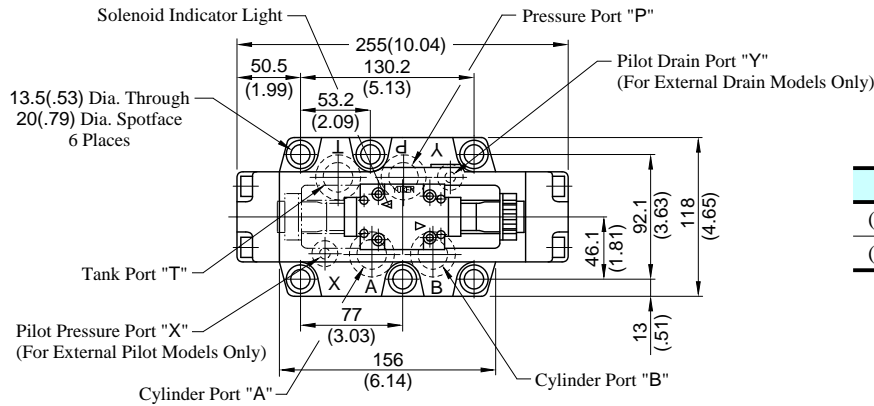

Model Numbers	"C" Thd.
(S-)DSHG-06-***-52	G 1/2
(S-)DSHG-06-***-5290	1/2 NPT

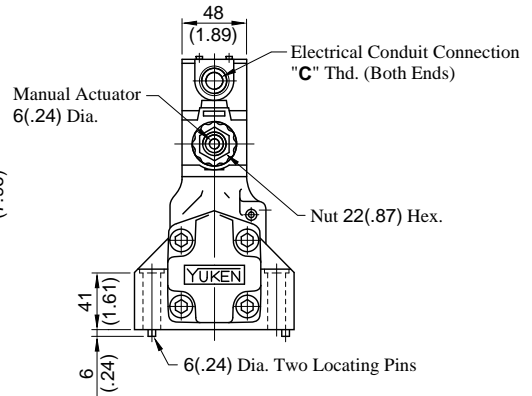
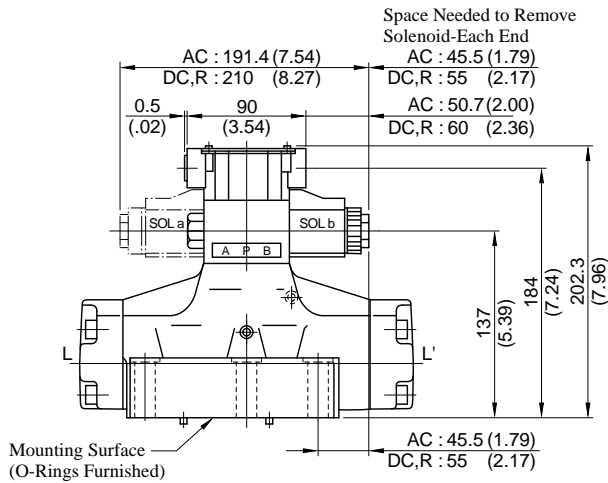

**DIMENSIONS IN
MILLIMETRES (INCHES)**

Plug-in Connector Type: (S-)DSHG-06-***-N₁-52/5290

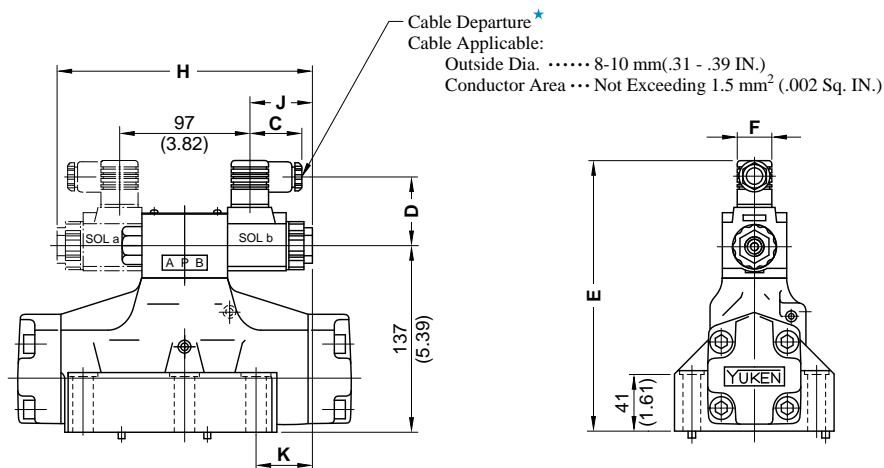

★ Position of cable departure can be changed. For details, refer to DSHG-01 valve on page 19.

Model Numbers	Dimensions mm (Inches)						
	C	D	E	F	H	J	K
(S-)DSHG-06-***-A*-N/N1	39 (1.54)	53 (2.09)	202 (7.95)	27.5 (1.08)	191.4 (7.54)	47.2 (1.86)	42.7 (1.68)
(S-)DSHG-06-***-D*-N/N1	39 (1.54)	64 (2.52)	213 (8.39)	27.5 (1.08)	210 (8.27)	56.5 (2.22)	52 (2.05)
(S-)DSHG-06-***-R*-N	53 (2.09)	57.2 (2.25)	216 (8.50)	34 (1.34)			

• For other dimensions, refer to "Terminal Box Type".

Installation Drawing

Terminal Box Type: (S-)DSHG-10-***-42/4290

Mounting surface:
ISO 4401-AF-10-4-A

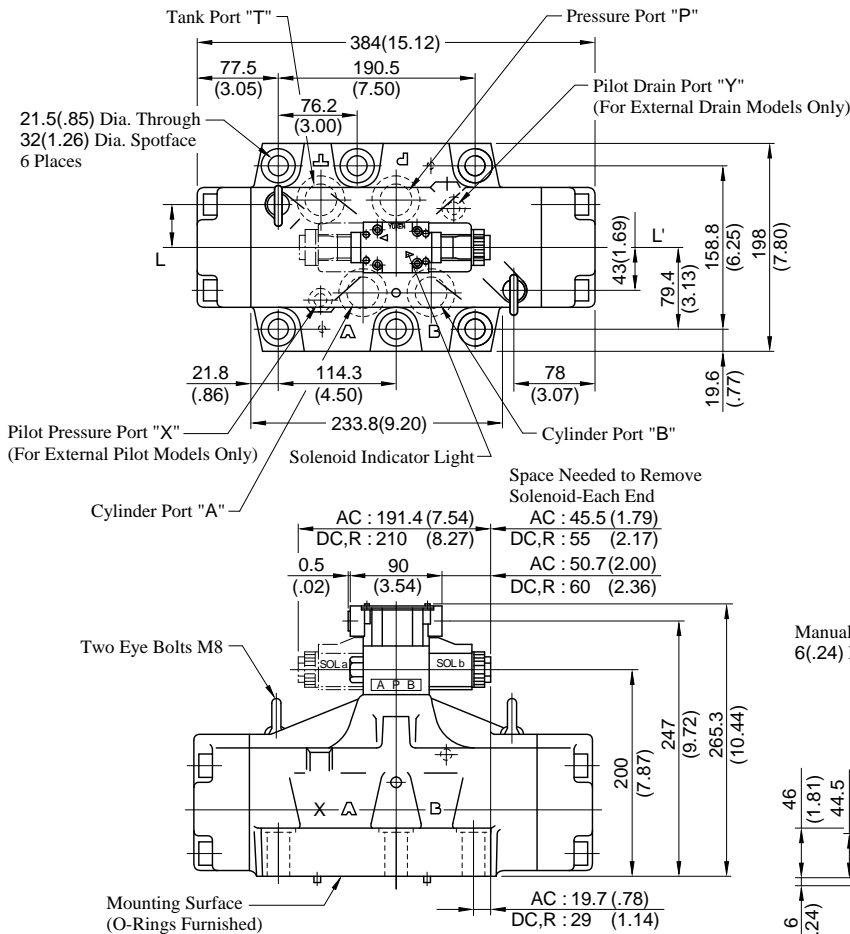

Model Numbers	"C" Thd.
(S-)DSHG-10-***-42	G 1/2
(S-)DSHG-10-***-4290	1/2 NPT

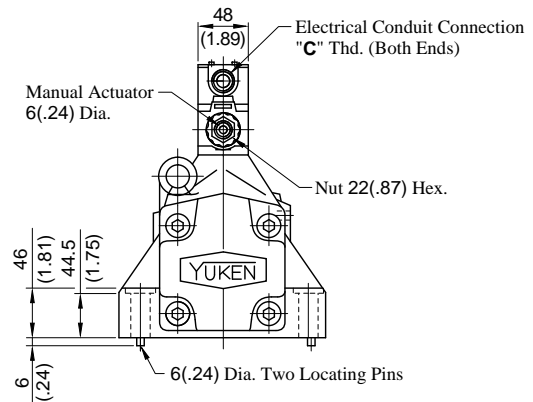

**DIMENSIONS IN
MILLIMETRES (INCHES)**

Plug-in Connector Type: (S-)DSHG-10-***-N₁-42/4290

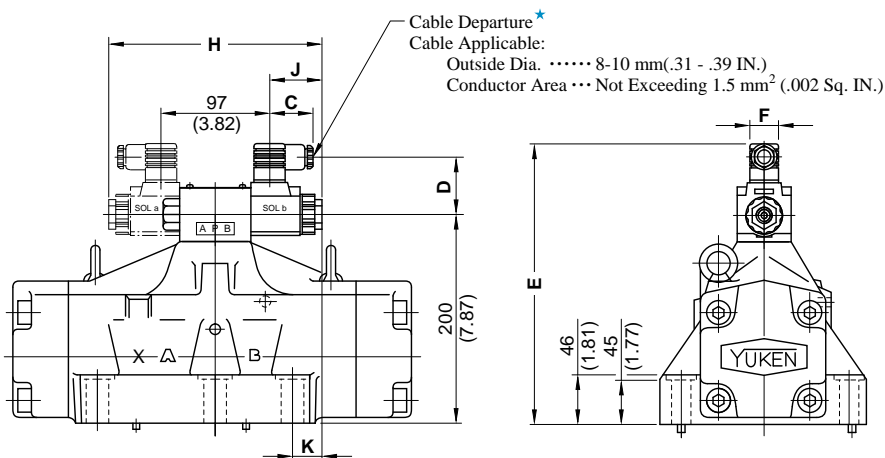

★ Position of cable departure can be changed. For details, refer to DSHG-01 valve on page 19.

Model Numbers	Dimensions mm (Inches)						
	C	D	E	F	H	J	K
(S-)DSHG-10-***-A*-N/N1	39 (1.54)	53 (2.09)	265 (10.43)	27.5 (1.08)	191.4 (7.54)	47.2 (1.86)	19.7 (.78)
(S-)DSHG-10-***-D*-N/N1	39 (1.54)	64 (2.52)	276 (10.87)	27.5 (1.08)	210 (8.27)	56.5 (2.22)	29 (1.14)
(S-)DSHG-10-***-R*-N	53 (2.09)	57.2 (2.25)	279 (10.98)	34 (1.34)	210 (8.27)	56.5 (2.22)	29 (1.14)

• For other dimensions, refer to "Terminal Box Type".

Options

Models with Pilot Choke Valve

Terminal Box Type

Plug-in Connector Type

● DSHG-03-***-C1/C2/C1C2

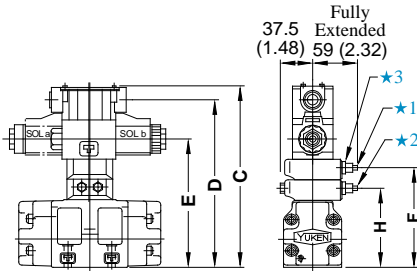

● DSHG-03-***-C1/C2/C1C2-N_{N1}

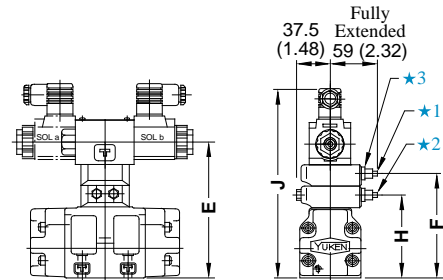

● (S-)DSHG-04-***-C1/C2/C1C2

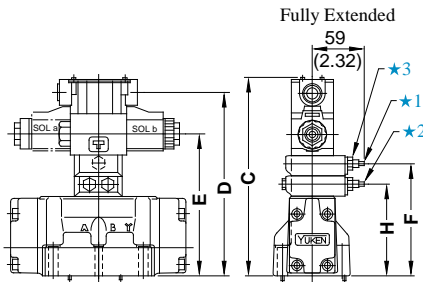

● (S-)DSHG-04-***-C1/C2/C1C2-N_{N1}

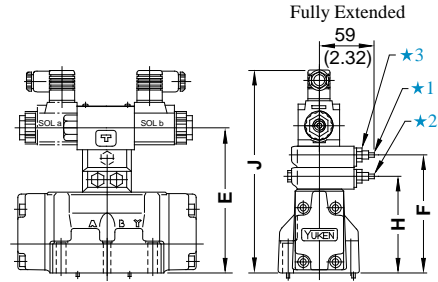

● (S-)DSHG-06-10-***-C1/C2/C1C2

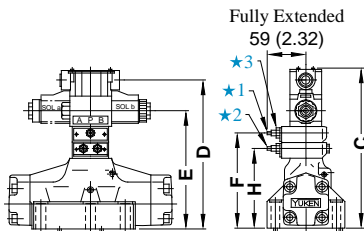

● (S-)DSHG-06-10-***-C1/C2/C1C2-N_{N1}

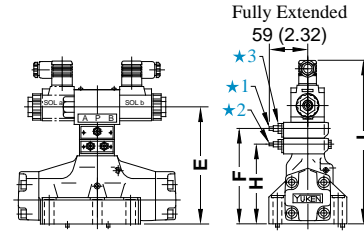

- ★1. "C1" Choke Adj. Screw 6 (.24) Hex.
- ★2. "C2" Choke Adj. Screw 6 (.24) Hex.
- ★3. Lock Nut 12 (.47) Hex.

DIMENSIONS IN
MILLIMETRES (INCHES)

Model Numbers	Dimensions mm (Inches)							
	C	D	E	F	H	J		
						AC SOL	DC SOL	R SOL
DSHG-03-***-C1	200.3 (7.89)	182 (7.17)	135 (5.31)	100 (3.94)	—	200 (7.87)	211 (8.31)	214 (8.43)
DSHG-03-***-C2				—	100 (3.94)			
DSHG-03-***-C1C2	225.3 (8.87)	207 (8.15)	160 (6.30)	125 (4.92)	100 (3.94)	225 (8.86)	236 (9.29)	239 (9.41)
(S-) DSHG-04-***-C1	206.3 (8.12)	188 (7.40)	141 (5.55)	106 (4.17)	—	206 (8.11)	217 (8.54)	220 (8.66)
(S-) DSHG-04-***-C2				—	106 (4.17)			
(S-) DSHG-04-***-C1C2	231.3 (9.11)	213 (8.39)	166 (6.54)	131 (5.16)	106 (4.17)	231 (9.09)	242 (9.53)	245 (9.65)
(S-) DSHG-06-***-C1	227.3 (8.95)	209 (8.23)	162 (6.38)	127 (5.00)	—	227 (8.94)	238 (9.37)	241 (9.49)
(S-) DSHG-06-***-C2				—	127 (5.00)			
(S-) DSHG-06-***-C1C2	252.3 (9.93)	234 (9.21)	187 (7.36)	152 (5.98)	127 (5.00)	252 (9.92)	263 (10.35)	266 (10.47)
(S-) DSHG-10-***-C1	290.3 (11.43)	272 (10.71)	225 (8.86)	190 (7.48)	—	390 (15.35)	401 (15.79)	404 (15.91)
(S-) DSHG-10-***-C2				—	190 (7.48)			
(S-) DSHG-10-***-C1C2	315.3 (12.41)	297 (11.69)	250 (9.84)	215 (8.46)	190 (7.48)	415 (16.34)	426 (16.77)	429 (16.89)

Options

Models with Stroke Adjustment

- **DSHG-03-***-R***

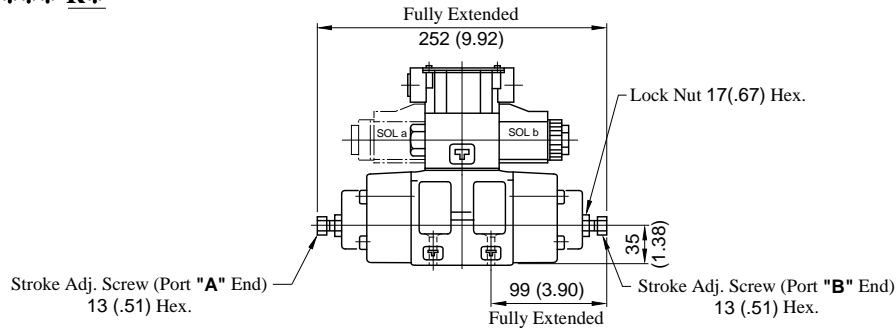

- **(S-)DSHG-04-***-R***

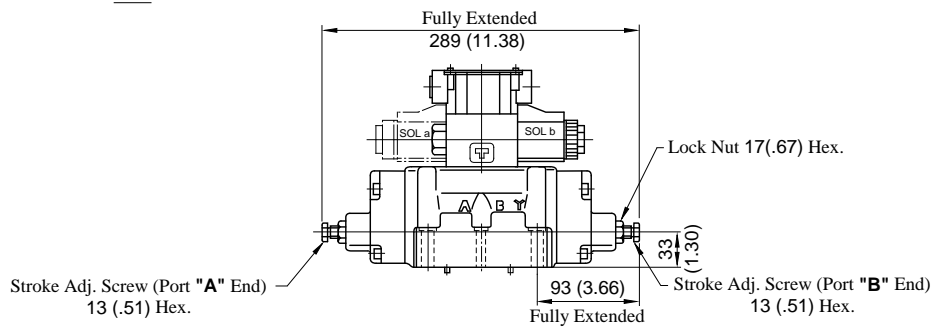

- **(S-)DSHG-06-***-R***

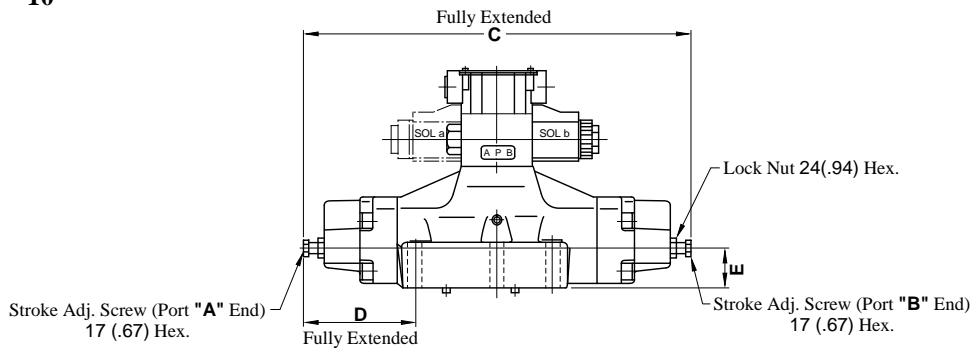

Model Numbers	C	D	E
(S-)DSHG-06-***-R2	376 (14.80)	111 (4.37)	40 (1.57)
(S-)DSHG-10-***-R2	558 (21.97)	164.5 (6.48)	65 (2.56)

DIMENSIONS IN MILLIMETRES (INCHES)

Pressure Centred Models

- **(S-)DSHG-06-3H***

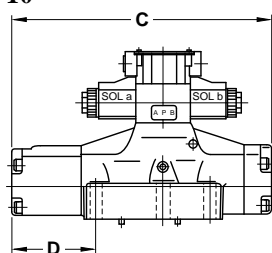

Model Numbers	C	D
(S-)DSHG-06-3H	306.5 (12.07)	102 (4.02)
*	456 (17.95)	149.5 (5.89)

Models with Pilot Piston

- **(S-)DSHG-06-***-P***

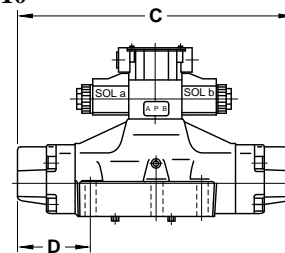

Model Numbers	C	D
(S-)DSHG-06-***-P2	323 (12.72)	84 (3.31)
(S-)DSHG-10-***-P2	479 (18.86)	125 (4.92)

Installation Drawing

● DHGM-03Y-10/1080/1090

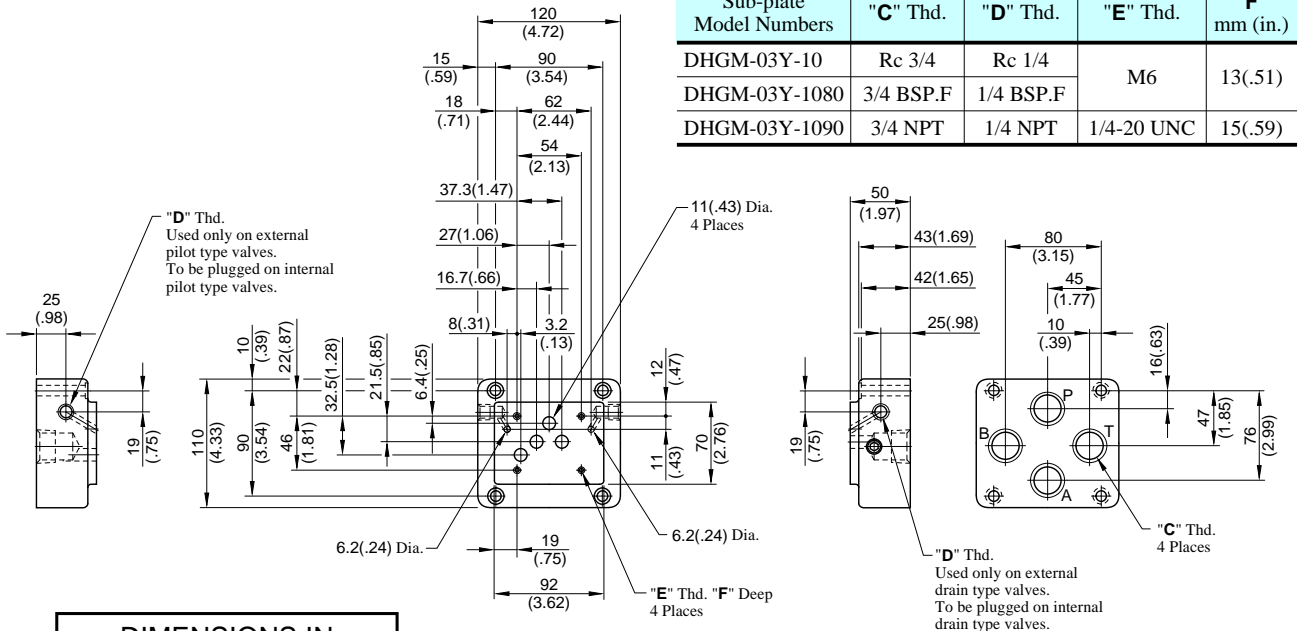

DIMENSIONS IN MILLIMETRES (INCHES)

● DHGM-04-20/2080/2090

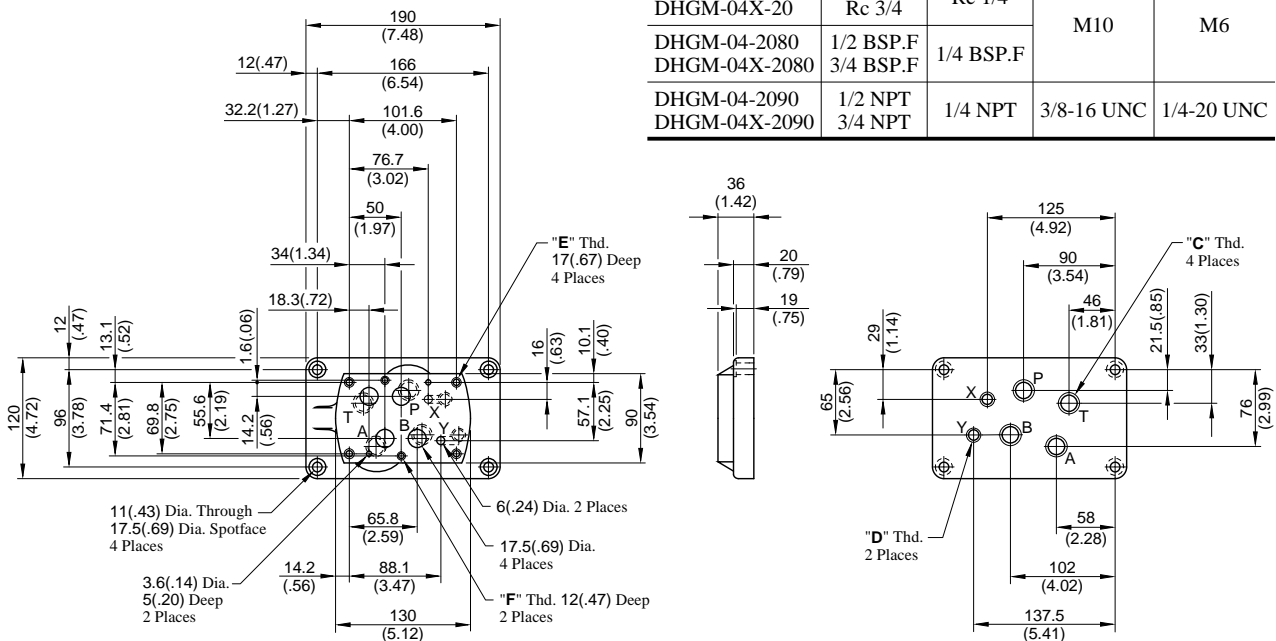

Sub-plate Model Numbers	"C" Thd.	"D" Thd.	"E" Thd.	"F" Thd.
DHGM-04-20 DHGM-04X-20	Rc 1/2 Rc 3/4	Rc 1/4	M10	M6
DHGM-04-2080 DHGM-04X-2080	1/2 BSP.F 3/4 BSP.F	1/4 BSP.F		
DHGM-04-2090 DHGM-04X-2090	1/2 NPT 3/4 NPT	1/4 NPT	3/8-16 UNC	1/4-20 UNC

Valve Types		Pilot Pressure Port "X"	Port "Y"
Solenoid Controlled Pilot Operated Directional Valves		Used only on external pilot type valves. To be plugged on internal pilot type valves.	Used as drain port only on external drain type valves. To be plugged on internal drain type valves.
Pilot Operated Directional Valves	Spring Centred No-spring	Used	Used as pilot pressure port
	Spring Offset		Used as pilot drain port
Manually Operated Directional Valves		Not used (plug is not required)	Used as drain port

Installation Drawing

● DHGM-06-06X-50/5090

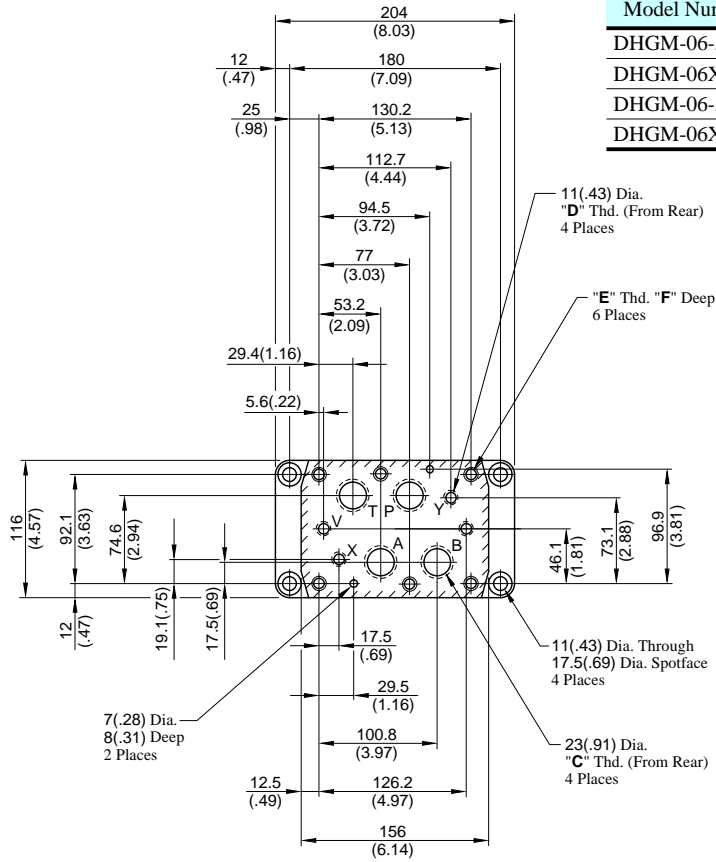

Sub-plate Model Numbers	"C" Thd.	"D" Thd.	"E" Thd.	F mm (in.)
DHGM-06-50	Rc 3/4	Rc 1/4	M12	24 (.94)
DHGM-06X-50	Rc 1			
DHGM-06-5090	3/4 NPT	1/4 NPT	1/2-13 UNC	26 (1.02)
DHGM-06X-5090	1 NPT			

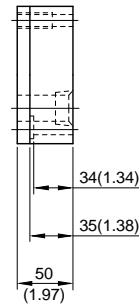

DIMENSIONS IN MILLIMETRES (INCHES)

● DHGM-06-06X-5080

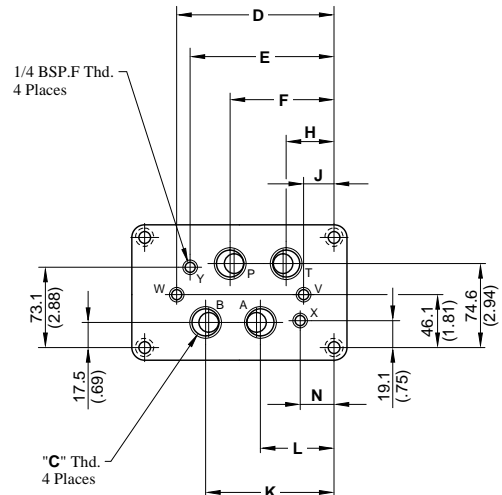
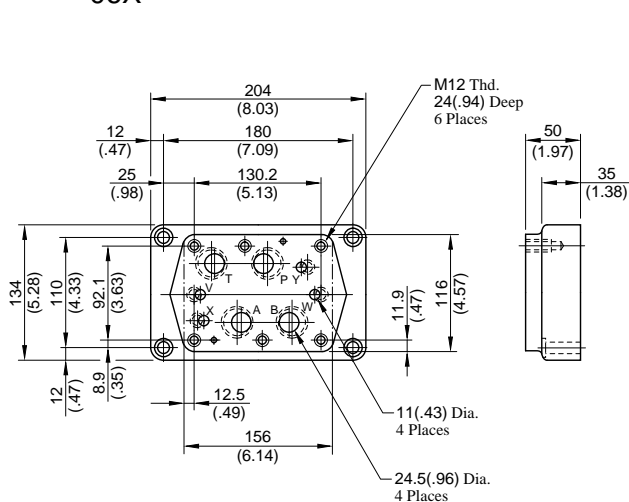

Sub-plate Model Numbers	"C" Thd.	Dimensions mm (Inches)							
		D	E	F	H	J	K	L	N
DHGM-06-5080	3/4 BSP.F	151.2 (5.95)	137.7 (5.42)	102 (4.02)	54.4 (2.14)	30.6 (1.20)	125.8 (4.95)	78.2 (3.08)	42.5 (1.67)
DHGM-06X-5080	1 BSP.F	155.2 (6.11)	148 (5.83)	106 (4.17)	50 (1.97)	25 (.98)	130 (5.12)	74 (2.91)	32 (1.26)

For other dimensions, refer to "DHGM-06*-50/5090" above.

* For Uses of Port "X", "Y", "V", "W", refer to DHGM-10* on the following page.



● DHGM-10_{10X}-40/4080/4090

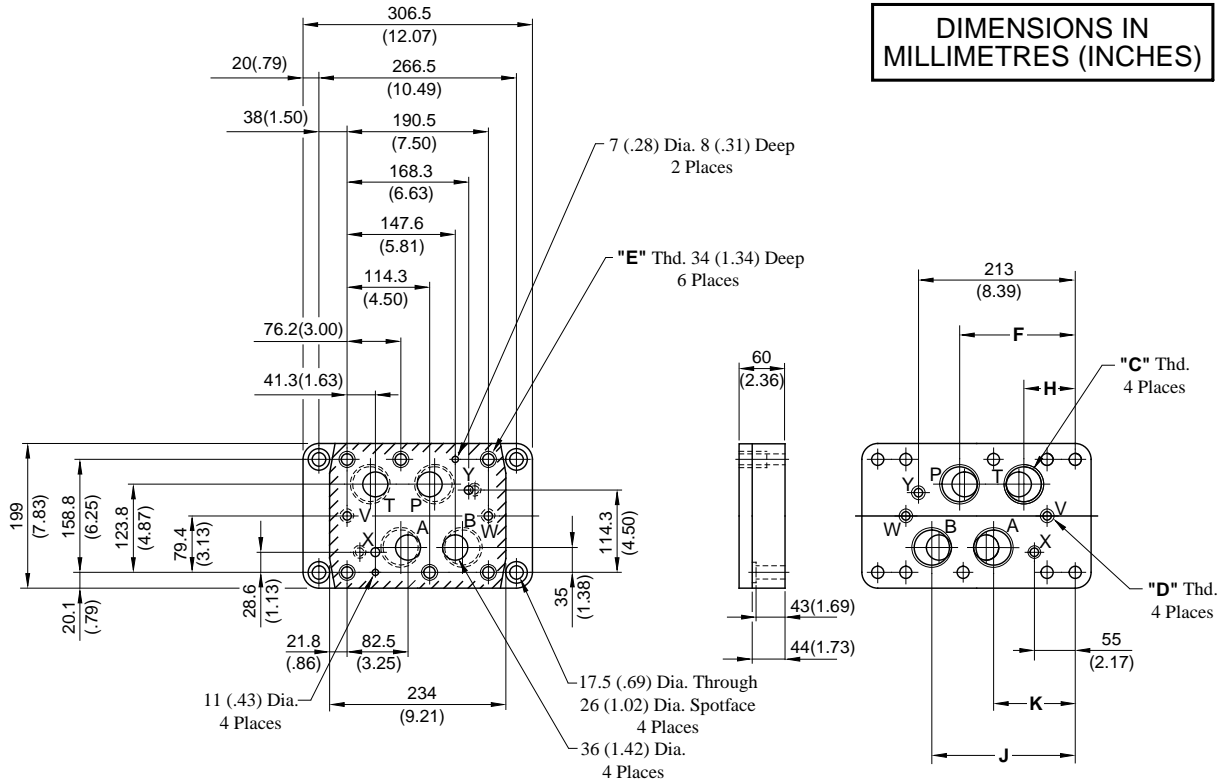

DIMENSIONS IN MILLIMETRES (INCHES)

Sub-plate Model Numbers	"C" Thd.	"D" Thd.	"E" Thd.	Dimensions mm (Inches)			
				F	H	J	K
DHGM-10-40	Rc 1-1/4	Rc 3/8	M20				
DHGM-10-4080	1-1/4 BSP.F	3/8 BSP.F	M20	152 (5.98)	79 (3.11)	185.5 (7.30)	120.5 (4.74)
DHGM-10-4090	1-1/4 NPT	3/8 NPT	3/4-10 UNC				
DHGM-10X-40	Rc 1-1/2	Rc 3/8	M20				
DHGM-10X-4080	1-1/2 BSP.F	3/8 BSP.F	M20	156 (6.14)	74 (2.91)	194.5 (7.66)	112.5 (4.43)
DHGM-10X-4090	1-1/2 NPT	3/8 NPT	3/4-10 UNC				

Note: Uses of port "X", "Y", "V", and "W"

Valve Types		Pilot Pres. Port "X"	Port "Y"	Drain Port "V"	Drain Port "W"
Solenoid Controlled Pilot Operated Directional Valves	Spring Centred, No-spring, Spring Offset	Used only on external pilot type valves.	Used as drain port only on external drain type valves.	Not used (plug is not required)	
	Pressure Centred			Used	Not used
	With Pilot Piston, Both Ends	To be plugged on internal pilot type valves.	To be plugged on* internal drain type valves.	Used	Used
	With Pilot Piston, Port "A" End			Used	Not used (plug is required)
	With Pilot Piston, Port "B" End			Not used (plug is required)	Used
Pilot Operated Directional Valves	Spring Centred, No-spring	Used	Used as pilot pres. port	Not used (plug is not required)	
	Spring Offset		Used as pilot drain port		
	Pressure Centred			Used	Not used
	With Pilot Piston, Both Ends		Used as pilot pres. port	Used	Used
	With Pilot Piston, Port "B" End		Used as pilot pres. port	Not used (plug is required)	Used
	With Pilot Piston Port "A" End		Spring Centred No-spring	Used as pilot pres. port	Used
	Spring Offset	Used as pilot drain port			
Manually Operated Directional Valves		Not used (plug is not required)	Not used (plug is not required)	Used	Not used (plug is not required)

* As the thread is provided on the body, plug either port on the sub-plate or port on the body.

Spare Parts List

DSHG-01-***-13/1380/1390

CAUTION

When making replacement of seals or pilot valves, please do it carefully after reading through the relevant instructions in the Operator's Manual.

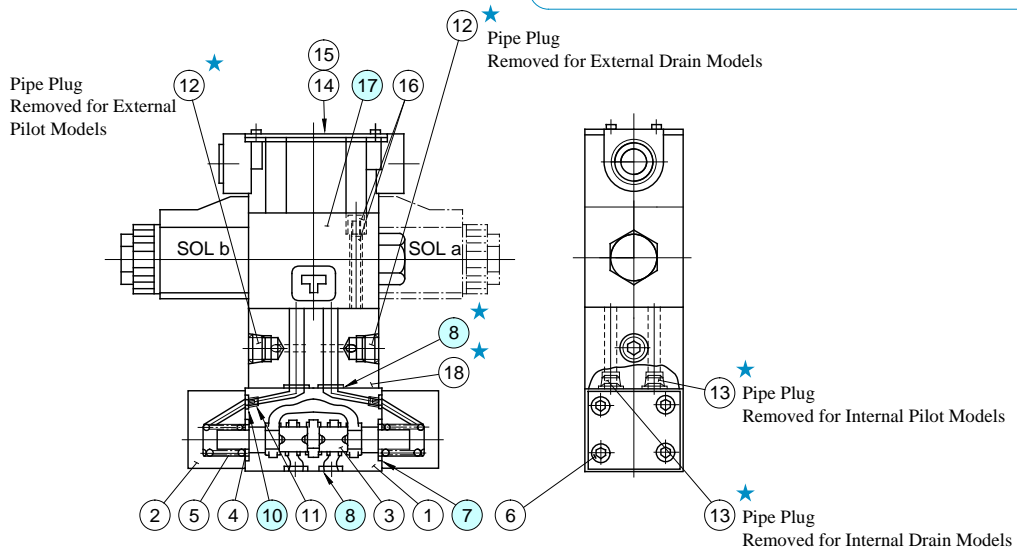

Note: Piece parts marked ★ are not available for internal pilot-internal drain type

DSHG-03-***-13/1390

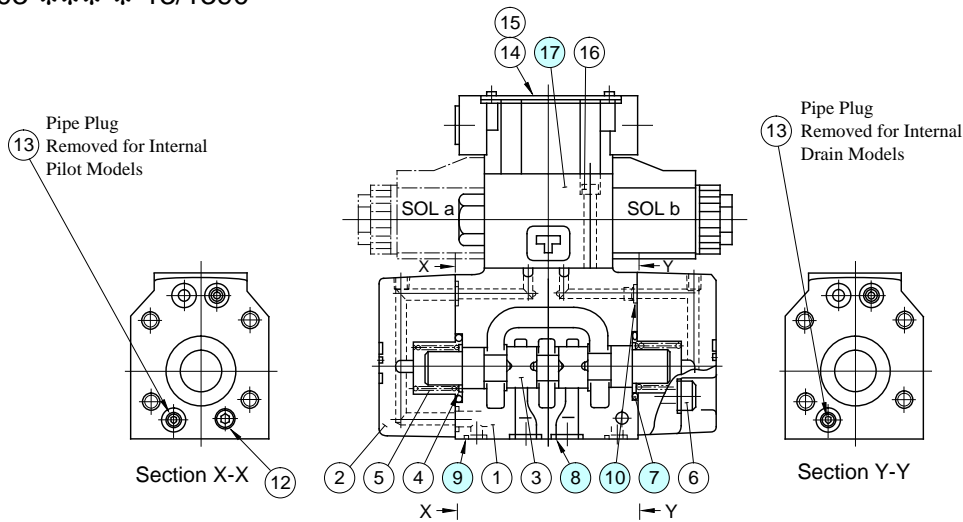

List of Seals

Item	Name	DSHG-01		DSHG-03	
		Part Numbers	Qty.	Part Numbers	Qty.
7	O-Ring	JASO-1018-1A	2	SO-NB-P28	2
8	O-Ring	SO-NB-P9	8(4)★	SO-NB-A104	5
9	O-Ring	—	—	SO-NB-P9	2
10	O-Ring	SO-NB-P5	2	SO-NB-P9	6

Pilot Valves

See page 31 for the pilot valve model numbers to be used.

★ Quantities in the () are applicable to internal pilot-internal drain.

Note: When ordering the o-rings, please specify the seal kit number listed in page 31. In addition to the above o-rings, o-rings for pilot valve is included in the seal kit.

For the detail of the pilot valve o-rings, see the catalogue No. Pub. EC-0402.



Spare Parts List

(S-)DSHG-04-***-51/5190

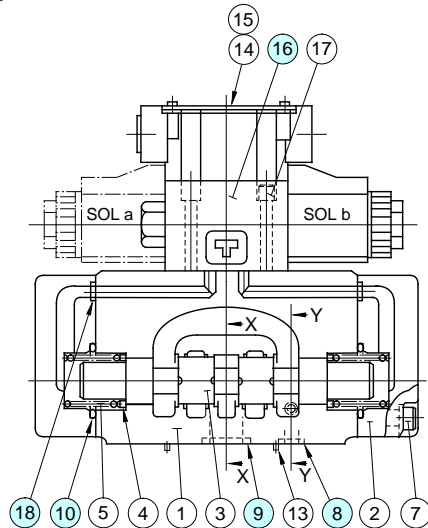

(S-)DSHG-06-***-52/5290

(S-)DSHG-10-***-42/4290

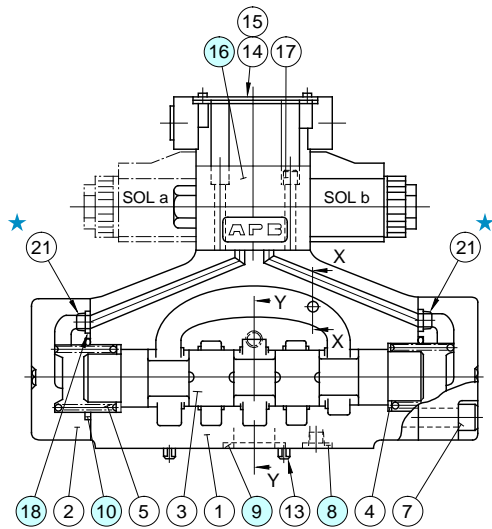

Note: Item ⑳ orifice marked ★ is applicable to pressure centred models (3H*) with pilot pressure more than 10 MPa (1450 PSI).

● List of Seals

Item	Name	Part Numbers			Qty.
		(S-)DSHG-04	(S-)DSHG-06	(S-)DSHG-10	
8	O-Ring	SO-NB-P9	SO-NB-P14	SO-NB-P20	2
9		SO-NB-P22	SO-NB-P30	SO-NB-P42	4
10		SO-NB-P34	SO-NB-P40	SO-NB-P65	2
18		SO-NB-P9	SO-NB-P10	SO-NB-P14	2

Note: When ordering the o-rings, please specify the seal kit number listed in page 31. In addition to the above o-rings, o-rings for pilot valve is included in the seal kit.

For the detail of the pilot valve o-rings, see the catalogue No. Pub. EC-0402.

⚠ CAUTION

When making replacement of seals or pilot valves, please do it carefully after reading through the relevant instructions in the Operator's Manual.

⑪ Pipe Plug
Removed for Internal
Drain Models

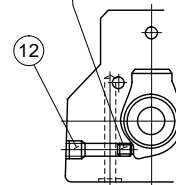

Section Y-Y

⑪ Pipe Plug
Removed for Internal
Pilot Models

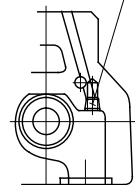

Section X-X

⑪ Pipe Plug
Removed for Internal
Pilot Models

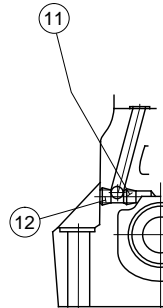

Section Y-Y

⑪ Pipe Plug
Removed for Internal
Drain Models

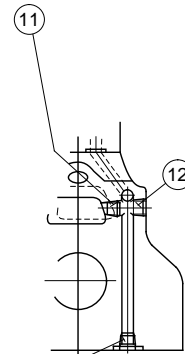

Section X-X

⑪ Pipe Plug
Removed for External
Drain Models

● Pilot Valves

See page 31 for the pilot valve model numbers to be used.

List of Pilot Valves & Seal Kits

Valve Model Numbers	Pilot Valve Model Numbers	Seal Kit Numbers
DSHG-01-3C*-★-▲-13 DSHG-01-3C*-★-N-1380 DSHG-01-3C*-★-▲-1390	DSG-01-3C4-★-▲-60 DSG-01-3C4-★-N-60 DSG-01-3C4-★-▲-6090	KS-DSHG-01-▲-13 (For Internal Pilot-Internal Drain)
DSHG-01-2B*-★-▲-13 DSHG-01-2B*-★-N-1380 DSHG-01-2B*-★-▲-1390	DSG-01-2B2-★-▲-60-L DSG-01-2B2-★-N-60-L DSG-01-2B2-★-▲-6090-L	
DSHG-03-3C*-★-▲-13 DSHG-03-3C*-★-▲-1390	DSG-01-3C4-★-▲-60 DSG-01-3C4-★-▲-6090	KS-DSHG-03-▲-13
DSHG-03-2B*-★-▲-13 DSHG-03-2B*-★-▲-1390	DSG-01-2B2-★-▲-60 DSG-01-2B2-★-▲-6090	
DSHG-03-2N*-★-▲-13 DSHG-03-2N*-★-▲-1390	DSG-01-2D2-★-▲-60 DSG-01-2D2-★-▲-6090	
(S-)DSHG-04-3C*-★-▲-51 (S-)DSHG-04-3C*-★-▲-5190	DSG-01-3C4-★-▲-60 DSG-01-3C4-★-▲-6090	KS-DSHG-04-▲-51
(S-)DSHG-04-2B*-★-▲-51 (S-)DSHG-04-2B*-★-▲-5190	DSG-01-2B2-★-▲-60 DSG-01-2B2-★-▲-6090	
(S-)DSHG-04-2N*-★-▲-51 (S-)DSHG-04-2N*-★-▲-5190	DSG-01-2D2-★-▲-60 DSG-01-2D2-★-▲-6090	
(S-)DSHG-06-3C*-★-▲-52 (S-)DSHG-06-3C*-★-▲-5290	DSG-01-3C4-★-▲-60 DSG-01-3C4-★-▲-6090	KS-DSHG-06-▲-52
(S-)DSHG-06-2B*-★-▲-52 (S-)DSHG-06-2B*-★-▲-5290	DSG-01-2B2-★-▲-60-L DSG-01-2B2-★-▲-6090-L	
(S-)DSHG-06-2N*-★-▲-52 (S-)DSHG-06-2N*-★-▲-5290	DSG-01-2D2-★-▲-60 DSG-01-2D2-★-▲-6090	
(S-)DSHG-10-3C*-★-▲-42 (S-)DSHG-10-3C*-★-▲-4290	DSG-01-3C4-★-▲-60 DSG-01-3C4-★-▲-6090	KS-DSHG-10-▲-42
(S-)DSHG-10-2B*-★-▲-42 (S-)DSHG-10-2B*-★-▲-4290	DSG-01-2B2-★-▲-60-L DSG-01-2B2-★-▲-6090-L	
(S-)DSHG-10-2N*-★-▲-42 (S-)DSHG-10-2N*-★-▲-4290	DSG-01-2D2-★-▲-60 DSG-01-2D2-★-▲-6090	

Notes) 1: Fill coil type (a symbol representing current/voltage) in section marked ★. Likewise, in section marked ▲, fill a symbol representing the type of electrical conduit connection (None: Terminal Box Type, N: Plug-in Connector Type).

2: For the details of the pilot valves, see the catalogue No. Pub.EC-0402.



Interchangeability between Current and New Design

● DSHG-01, 03

In accordance with the improvement of the pilot valve (DSG-01), DSHG-01 and -03 have been model-changed (from 12-design to 13-design).

Descriptions	Model No.	Current	New
			DSHG-01-***-12*
Specifications	No changes		
Interchangeability in Mtg.	Yes		
Pilot Valve		DSG-01-***-50*	DSG-01-***-60*
For details, refer to the Catalogue No. Pub. EC-0402			

Current

New

● DSHG-01

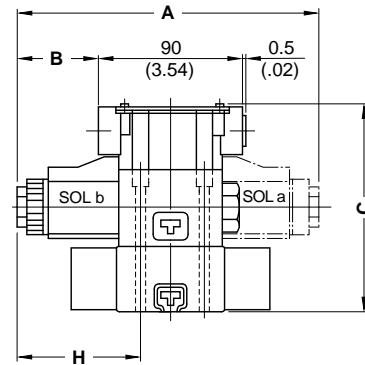
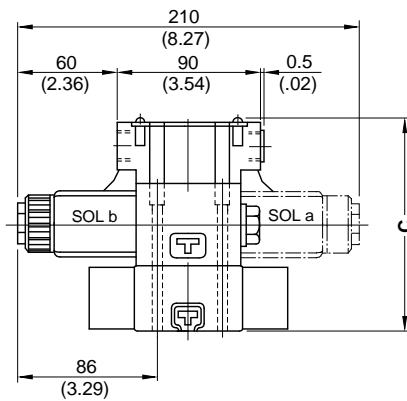

Model No.	C
DSHG-01-T	130.3 (5.13)
DSHG-01-E/ET/None	170.3 (6.70)

Model No.		A	B	C	H
DSHG-01-T	AC	191.4 (7.54)	50.7 (2.00)	130.3 (5.13)	76.7 (3.02)
	DC	210 (8.27)	60 (2.36)		86 (3.39)
	R				
DSHG-01-E/ET/None	AC	191.4 (7.54)	50.7 (2.00)	170.3 (6.70)	76.7 (3.02)
	DC	210 (8.27)	60 (2.36)		86 (3.39)
	R				

**DIMENSIONS IN
MILLIMETRES (INCHES)**

● DSHG-03

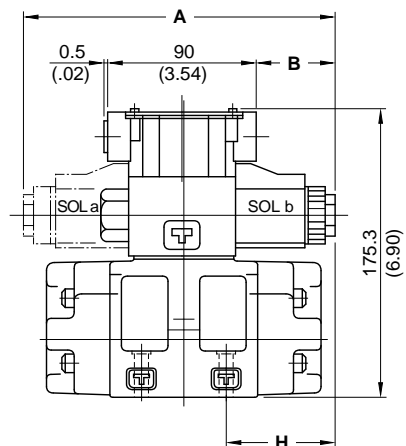
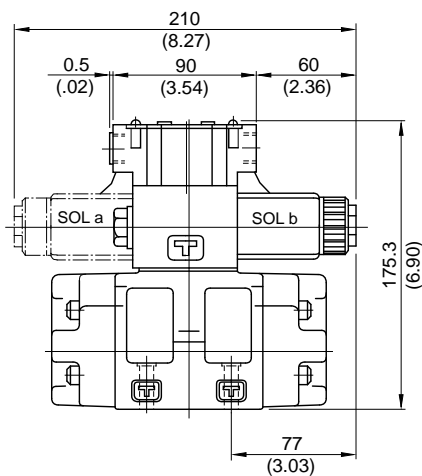

Model No.		A	B	H
DSHG-03	AC	191.4 (7.54)	50.7 (2.00)	67.7 (2.67)
	DC	210 (8.27)	60 (2.36)	77 (3.03)
	R			

Interchangeability between Current and New Design

● (S)-DSHG-04

(S-) DSHG-04 has been model changed in accordance with the improvement of the pilot valve (DSG-01). For details, see the following.

Descriptions	Model No.	Current (S-)DSHG-04-***-50*	New (S-)DSHG-04-***-51*
Specifications	No changes		
Interchangeability in Mtg.	Yes		
Pilot Valve		DSG-01-***-50*	DSG-01-***-60*
For details, refer to the Catalogue No. Pub. EC-0402.			

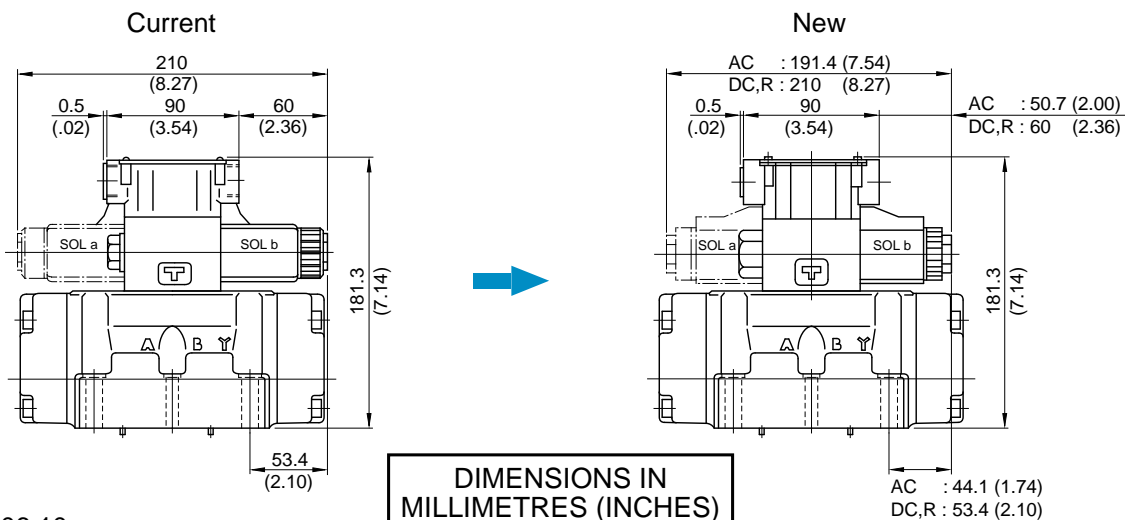

● (S)-DSHG-06,10

(S-) DSHG-06 and -10 have been model changed in accordance with the improvement of the pilot valve (DSG-01). For details, see below.

Descriptions	Model No.	Current (S-)DSHG-06-***-51* (S-)DSHG-10-***-41*	New (S-)DSHG-06-***-52* (S-)DSHG-10-***-42*
Specifications	No changes		
Interchangeability in Mtg.	Yes		
Pilot Valve		DSG-01-***-50*	DSG-01-***-60*
For details, refer to the Catalogue No. Pub. EC-0402			

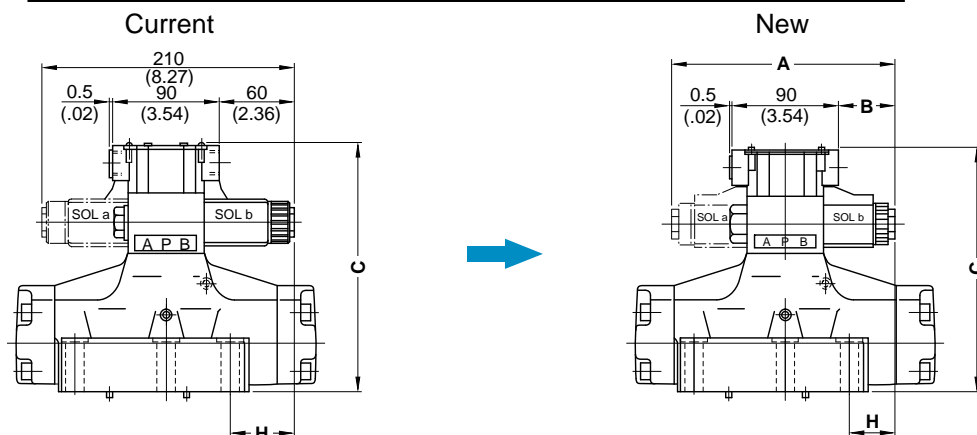

Model No.	C	H
(S-)DSHG-06	202.3 (7.96)	51.3 (2.02)
(S-)DSHG-10	265.3 (10.44)	28.5 (1.12)

Model No.	A	B	C	H	
(S-)DSHG-06	AC	191.4 (7.54)	50.7 (2.00)	202.3 (7.96)	42.7 (1.68)
	DC	210 (8.27)	60 (2.36)		
	R			52 (2.05)	
(S-)DSHG-10	AC	191.4 (7.54)	50.7 (2.00)	265.3 (10.44)	19.7 (.78)
	DC	210 (8.27)	60 (2.36)		
	R			29 (1.14)	