

**YUKEN**

## MULTI-PURPOSE CONTROL VALVES DSLHG-04/06/10 (1/2,3/4,1-1/4) Sub-plate Mounting

DIRECTIONAL  
CONTROLS

Up to 25 MPa (3630 PSI), 500 L/min (132 U.S.GPM)

### *The Yuken Multi-Purpose Control Valves Comply with The Needs of Reducing Cost and Size of Your Machine*

YUKEN's Multi Purpose Control Valves are compound valves composed of the main valve having four poppets, 1/8 Solenoid Operated Directional Valves for pilot and Pilot Selector Valves. This valve is multifunctionalized by having individual poppet had functions such as directional control, flow control or pressure control according to the combination of the main valve and pilot selector valve.

#### ■ Features

##### ● Multi-purpose control valves

The valves combine three functions of directional control, flow control and of pilot operated check valve (or counterbalance valve). The valves contribute for reducing a number of valves in applications and space for installation and then eventually leads to reduction in size and cost of your machines.

##### ● Quick response, High reliability

Changeover response time is very quick as the valves are poppet type, there is no over-lap.

No hydraulic lock occurs as there is no leakage of pressurised oil from the seat parts.

##### ● Easy to reduce shock in your hydraulic system

By selecting proper diameter of orifice for pilot, the open/close timing of the flow passage can be set freely. Therefore, smooth starting and stopping of actuator can be done combined with using shockless type poppet. Noise of ON/OFF and vibration of piping in hydraulic system can be also reduced.

##### ● For regenerative circuit

4 position-4 way type, which is to compose regenerative circuit, is available. By adopting regenerative circuit, gaining fast feed speed by using smaller volume pump is possible. Therefore saving electric power of system is possible.

##### ● The mounting dimensions are conformed with ISO standard

The valves are interchangeable with our conventional valves in mounting.

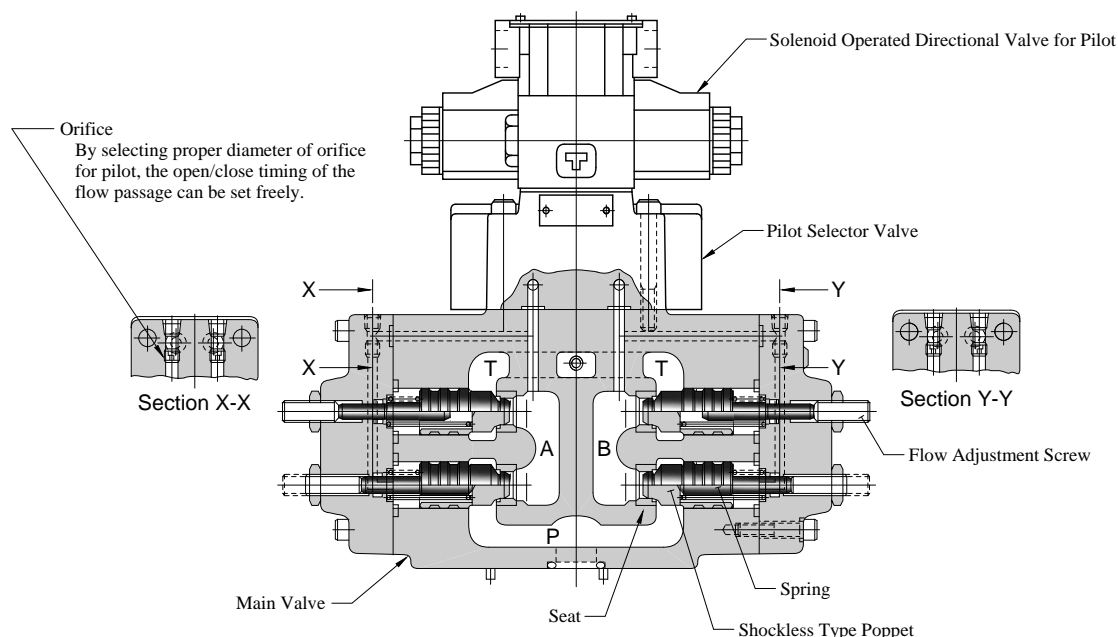
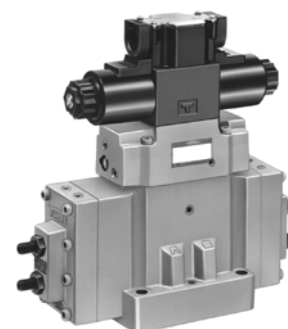
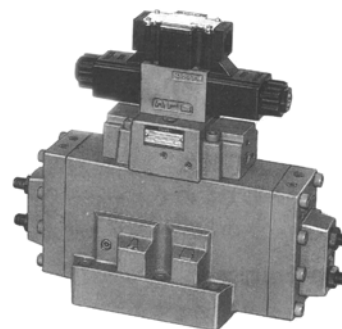

#### ■ Specifications

Model Numbers	Max. Flow L/min (U.S.GPM)	Max. Operating Pressure MPa (PSI)	Max. Pilot Pressure MPa (PSI)	Max. T-Line Back Pres. MPa (PSI)	Pressure Adj. Range of Counterbalance MPa (PSI)	Ratio of Poppet Area (Seat Area: Annular Area)		Approx. Mass kg (lbs.)
						Direction & Flow Control	Pressure Control	
DSLHG-04-1*-*-12*	150 (39.6)	25 (3630)	25 (3630)	16 (2320)	—	1:1	—	15 (33)
DSLHG-04-2*-*-12*								15 (33)
DSLHG-04-3*-*-12*								19 (42)
DSLHG-04-4*-*-12*	150 {100}* (39.6 {26.4})	25 (3630)	25 (3630)	16 (2320)	Refer to Model No. Designation	1:1	24:1	20 (44)
DSLHG-04-5*-*-12*								22.5 (50)
DSLHG-06-1*-*-12*	300 (79.3)	25 (3630)	25 (3630)	16 (2320)	—	1:1	—	26.5 (59)
DSLHG-06-2*-*-12*								26.5 (59)
DSLHG-06-3*-*-12*								28 (62)
DSLHG-06-4*-*-12*	300 {200}* (79.3 {52.8})	25 (3630)	25 (3630)	16 (2320)	Refer to Model No. Designation	1:1	24:1	31 (68)
DSLHG-06-5*-*-12*								34.5 (76)
DSLHG-10-1*-*-12*	500 (132)	25 (3630)	25 (3630)	16 (2320)	—	1:1	—	59 (130)
DSLHG-10-2*-*-12*								59 (130)
DSLHG-10-3*-*-12*								62 (137)
DSLHG-10-4*-*-12*	500 {300}* (132 {79.3})	25 (3630)	25 (3630)	16 (2320)	Refer to Model No. Designation	1:1	24:1	63.5 (140)
DSLHG-10-5*-*-12*								67 (148)

★ In case of counterbalance function line, maximum flow is limited to the values in brackets.

#### ■ Solenoid Ratings

Electric Source	Coil Type	Frequency (Hz)	Voltage (V)		Current & Power at Rated Voltage				
			Source Rating	Serviceable Range	Inrush (A)★	Holding (A)	Power (W)		
AC	A100	50	100	80 - 110	2.42	0.51	—		
			100	90 - 120	2.14	0.37			
					110	2.35		0.44	
	A120	50	120	96 - 132	2.02	0.42			
					108 - 144	1.78		0.31	
	A200	50	200	160 - 220	1.21	0.25			
					200	180 - 240		1.07	0.19
								220	1.18
	A240	50	240	192 - 264	1.01	0.21			
					216 - 288	0.89		0.15	
DC (K Series)	D12	—	12	10.8 - 13.2	—	2.45	29		
	D24		24	21.6 - 26.4		1.23			
	D48		48	43.2 - 52.8		0.61			
AC→DC Rectified	R100	50/60	100	90 - 110	—	0.33	29		
	R200		200	180 - 220		0.16			

★ Inrush current in the above table shows rms values at maximum stroke.

The coil type numbers in the shaded column are handled as optional extras. In case these coils are required to be chosen, please confirm the time of delivery with us before ordering.

### Model Number Designation

#### Model Number Designation

F-	DSLH	G	-04	-4	A	-B	-E	T	-A100	-C	-N	-12	*
Special Seals	Series Number	Type of Mounting	Valve Size	Type of Pilot Control	Counterbalance Function	Pressure Adj. Range of Counterbalance MPa (PSI)	Pilot Connection	Drain <sup>★2</sup> Connection	Coil Type	Manual Override	Electrical Conduit Connection	Design Number	Design Standards
<b>F:</b> For phosphate ester type fluids (Omit if not required)	<b>DSLH:</b> Multi-Purpose Control Valve	<b>G</b> Sub-plate Mounting	<b>04</b>	1	—	—	<b>None:</b> Internal Pilot  <b>E:</b> External Pilot	<b>None:</b> External Drain  <b>T:</b> Internal Drain	AC: <b>A100</b> <b>A120</b> <b>A200</b> <b>A240</b>	<b>None:</b> Manual Override Pin  <b>C:</b> Push Button & Lock Nut (Options)	<b>None:</b> Terminal Box Type  <b>N:</b> Plug-in Connector Type	<b>12</b>	<b>None:</b> Japanese Std. "JIS" <b>90:</b> N.American Design Std.
				2	—	<b>B:</b> *★1 - 7 (*★1 - 1020) <b>H:</b> 6 - 25 (870 - 3630)							
				3	—								
				4	A : AT Line W : AT & BT Lines				<b>None:</b> *★1 - 25 (*★1 - 3630)				
				5	—								
			<b>06</b>	1	—	<b>None:</b> *★1 - 25 (*★1 - 3630)	<b>None:</b> External Drain  <b>T:</b> Internal Drain	<b>A:</b> AT Line <b>W:</b> AT & BT Lines	<b>None:</b> *★1 - 25 (*★1 - 3630)	<b>None:</b> Manual Override Pin  <b>C:</b> Push Button & Lock Nut (Options)	<b>None:</b> Terminal Box Type  <b>N:</b> Plug-in Connector Type	<b>12</b>	<b>None:</b> Japanese Std. "JIS" & European Design Std. <b>90:</b> N.American Design Std.
				2	—								
				3	—								
				4	A : AT Line W : AT & BT Lines								
				5	—								
<b>10</b>	1	—	<b>None:</b> *★1 - 25 (*★1 - 3630)	<b>None:</b> External Drain  <b>T:</b> Internal Drain	<b>A:</b> AT Line <b>W:</b> AT & BT Lines	<b>None:</b> *★1 - 25 (*★1 - 3630)	<b>None:</b> Manual Override Pin  <b>C:</b> Push Button & Lock Nut (Options)	<b>None:</b> Terminal Box Type  <b>N:</b> Plug-in Connector Type	<b>12</b>	<b>None:</b> Japanese Std. "JIS" & European Design Std. <b>90:</b> N.American Design Std.			
	2	—											
	3	—											
	4	A : AT Line W : AT & BT Lines											
	5	—											
See page 5 for functions and purpose of use.													

★1. See "Min. Adjustment Pressure", page 7, for information on minimum adjustment pressure.

★2. In case of lines with counterbalance function (-4<sup>A</sup>, -5<sup>A</sup>), External Drain must be selected for Drain Connection.

In the table above, the symbols or numbers highlighted with shade represent the optional extras. The valves with model number having such optional extras are handled as options, therefore, please confirm the time of delivery with us before ordering.



## ■ Hydraulic Fluids

### ● Fluid Types

Any type of hydraulic fluids listed in the table below can be used.

Petroleum base oils	Use fluids equivalent to ISO VG 32 or VG 46.
Synthetic fluids	Use phosphate ester or polyol ester fluid. When phosphate ester fluid is used, prefix "F-" to the model number because the special seals (fluororubber) are required to be used.
Water containing fluids	Use water-glycol fluids or W/O emulsion fluids.

Note: For use with hydraulic fluids other than those listed above, please consult your Yuken representatives in advance.

### ● Recommended Viscosity and Oil Temperatures

Viscosity ranging between 15 - 400 mm<sup>2</sup>/s (77 - 1800 SSU).

Oil temperatures between -15/+70°C (5 - 158°F).

Use hydraulic fluids which satisfy the recommended viscosity and oil temperatures given above.

### ● Control of Contamination

Due caution must be paid to maintaining control over contamination of the hydraulic fluids which may otherwise lead to breakdowns and shorten the life of the valves. Please maintain the degree of contamination within NAS 1638-Grade 12. Use 25 μm or finer line filter.

## ■ Sub-plate

Valve Model Numbers	Japanese Standard "JIS"			European Design Standard			N. American Design Standard		
	Sub-plate Model Numbers	Thread Size	Approx. Mass kg (lbs.)	Sub-plate Model Numbers	Thread Size	Approx. Mass kg (lbs.)	Sub-plate Model Numbers	Thread Size	Approx. Mass kg (lbs.)
DSLHG-04	DHGM-04-20	Rc 1/2	4.4 (9.7)	DHGM-04-2080	1/2 BSP.F	4.4 (9.7)	DHGM-04-2090	1/2 NPT	4.4 (9.7)
	DHGM-04X-20	Rc 3/4	4.1 (9.0)	DHGM-04X-2080	3/4 BSP.F	4.1 (9.0)	DHGM-04X-2090	3/4 NPT	4.1 (9.0)
DSLHG-06	DHGM-06-50	Rc 3/4	7.4 (16.3)	DHGM-06-5080	3/4 BSP.F	8.5 (18.7)	DHGM-06-5090	3/4 NPT	7.4 (16.3)
	DHGM-06X-50	Rc 1	7.4 (16.3)	DHGM-06X-5080	1 BSP.F	8.5 (18.7)	DHGM-06X-5090	1 NPT	7.4 (16.3)
DSLHG-10	DHGM-10-40	Rc 1-1/4	21.5 (47.4)	DHGM-10-4080	1-1/4 BSP.F	21.5 (47.4)	DHGM-10-4090	1-1/4 NPT	21.5 (47.4)
	DHGM-10X-40	Rc 1-1/2	21.5 (47.4)	DHGM-10X-4080	1-1/2 BSP.F	21.5 (47.4)	DHGM-10X-4090	1-1/2 NPT	21.5 (47.4)

● Sub-plates are available. Specify the sub-plate model number from the table above.

When sub-plates are not used, the mounting surface should have a good machined finish.

## ■ Mounting Bolts

Socket head cap screws in the table below are included.

Model Numbers	Socket Head Cap Screw			
	Japanese Standard "JIS" and European Design Standard	N. American Design Standard	Qty.	Tightening Torque Nm (In. lbs.)
DSLHG-04	M6 × 40 Lg.	1/4-20 UNC × 1-1/2 Lg.	2	12-15 (106-133)
	M10 × 45 Lg.	3/8-16 UNC × 1-3/4 Lg.	4	58-72 (513-637)
DSLHG-06	M12 × 60 Lg.	1/2-13 UNC × 2-1/2 Lg.	6	100-123 (885-1089)
DSLHG-10	M20 × 75 Lg.	3/4-10 UNC × 3 Lg.	6	473-585 (4186-5177)

#### Function and Purpose of Use

Type of Pilot Control	Model No.	Graphic Symbols	Function			Purpose of Use									
			Directional Control	Flow Control	Pilot Operated Check Valve / Pressure Control										
Type "1"	DSLHG-*1					<ul style="list-style-type: none"> <li>Functions as Three Position Four-Way Valve (Spring Centred Model).</li> </ul>									
							<table border="1"> <thead> <tr> <th>Position</th> <th>#1</th> <th>#2</th> <th>#3</th> </tr> </thead> <tbody> <tr> <td>SOL a</td> <td>ON</td> <td>OFF</td> <td>OFF</td> </tr> <tr> <td>SOL b</td> <td>OFF</td> <td>OFF</td> <td>ON</td> </tr> </tbody> </table>	Position	#1	#2	#3	SOL a	ON	OFF	OFF
Position	#1	#2	#3												
SOL a	ON	OFF	OFF												
SOL b	OFF	OFF	ON												
Type "2"	DSLHG-*2			<p>Both Metre-in and Metre-out are possible</p>	<p>To get a function of pilot operated check valve, the following conditions should be fulfilled.</p> <ul style="list-style-type: none"> <li>Internal pilot type ("P" port pressure) <math>\geq</math> ("A""B" ports pressure)</li> <li>External pilot type (Pilot pressure) <math>\geq</math> ("A""B" ports pressure)</li> </ul>	<ul style="list-style-type: none"> <li>Functions as Three Position Four-Way Valve (Spring Centred Model) as well as Two Position Valve which uses positions #1 and #3.</li> <li>Effective especially when the actuator has inertia force.</li> </ul>									
							<table border="1"> <thead> <tr> <th>Position</th> <th>#1</th> <th>#2</th> <th>#3</th> </tr> </thead> <tbody> <tr> <td>SOL a</td> <td>ON</td> <td>OFF</td> <td>OFF</td> </tr> <tr> <td>SOL b</td> <td>OFF</td> <td>OFF</td> <td>ON</td> </tr> </tbody> </table>	Position	#1	#2	#3	SOL a	ON	OFF	OFF
Position	#1	#2	#3												
SOL a	ON	OFF	OFF												
SOL b	OFF	OFF	ON												
Type "3"	DSLHG-*3					<ul style="list-style-type: none"> <li>Functions as Four Position Four-Way Valve.</li> <li>Regenerative circuit can be constructed at the Position #3.</li> </ul>									
							<table border="1"> <thead> <tr> <th>Position</th> <th>#1</th> <th>#2</th> <th>#3</th> <th>#4</th> </tr> </thead> <tbody> <tr> <td>SOL a</td> <td>ON</td> <td>OFF</td> <td>ON</td> <td>OFF</td> </tr> <tr> <td>SOL b</td> <td>OFF</td> <td>OFF</td> <td>ON</td> <td>ON</td> </tr> </tbody> </table>	Position	#1	#2	#3	#4	SOL a	ON	OFF
Position	#1	#2	#3	#4											
SOL a	ON	OFF	ON	OFF											
SOL b	OFF	OFF	ON	ON											
Type "4"	DSLHG-*4A					<ul style="list-style-type: none"> <li>Pressure control function (counterbalance valve) has been added to Type "2" to make this type.</li> </ul>									
							<table border="1"> <thead> <tr> <th>Position</th> <th>#1</th> <th>#2</th> <th>#3</th> </tr> </thead> <tbody> <tr> <td>SOL a</td> <td>ON</td> <td>OFF</td> <td>OFF</td> </tr> <tr> <td>SOL b</td> <td>OFF</td> <td>OFF</td> <td>ON</td> </tr> </tbody> </table>	Position	#1	#2	#3	SOL a	ON	OFF	OFF
Position	#1	#2	#3												
SOL a	ON	OFF	OFF												
SOL b	OFF	OFF	ON												
Type "4"	DSLHG-*4W					<ul style="list-style-type: none"> <li>Used to control the back pressure of the actuator.</li> </ul>									
							<table border="1"> <thead> <tr> <th>Position</th> <th>#1</th> <th>#2</th> <th>#3</th> </tr> </thead> <tbody> <tr> <td>SOL a</td> <td>ON</td> <td>OFF</td> <td>OFF</td> </tr> <tr> <td>SOL b</td> <td>OFF</td> <td>OFF</td> <td>ON</td> </tr> </tbody> </table>	Position	#1	#2	#3	SOL a	ON	OFF	OFF
Position	#1	#2	#3												
SOL a	ON	OFF	OFF												
SOL b	OFF	OFF	ON												
Type "5"	DSLHG-*5A					<ul style="list-style-type: none"> <li>Pressure control function (counterbalance valve) has been added to Type "3" to make this type.</li> </ul>									
							<table border="1"> <thead> <tr> <th>Position</th> <th>#1</th> <th>#2</th> <th>#3</th> <th>#4</th> </tr> </thead> <tbody> <tr> <td>SOL a</td> <td>ON</td> <td>OFF</td> <td>ON</td> <td>OFF</td> </tr> <tr> <td>SOL b</td> <td>OFF</td> <td>OFF</td> <td>ON</td> <td>ON</td> </tr> </tbody> </table>	Position	#1	#2	#3	#4	SOL a	ON	OFF
Position	#1	#2	#3	#4											
SOL a	ON	OFF	ON	OFF											
SOL b	OFF	OFF	ON	ON											
Type "5"	DSLHG-*5W					<ul style="list-style-type: none"> <li>Used to control the back pressure of the actuator.</li> </ul>									
							<table border="1"> <thead> <tr> <th>Position</th> <th>#1</th> <th>#2</th> <th>#3</th> <th>#4</th> </tr> </thead> <tbody> <tr> <td>SOL a</td> <td>ON</td> <td>OFF</td> <td>ON</td> <td>OFF</td> </tr> <tr> <td>SOL b</td> <td>OFF</td> <td>OFF</td> <td>ON</td> <td>ON</td> </tr> </tbody> </table>	Position	#1	#2	#3	#4	SOL a	ON	OFF
Position	#1	#2	#3	#4											
SOL a	ON	OFF	ON	OFF											
SOL b	OFF	OFF	ON	ON											



#### ■ Instructions

##### ● Pilot Pressure

Pilot pressure of external pilot drain models must always exceed the pressure of the main pressure port "P".

##### ● Pilot Drain Port

Avoid connecting the pilot drain port to a line with possible surge pressure.

##### ● Drain Connection when with Counterbalance Function

When a valve having counterbalance function is used with internal drain type, the counterbalance pilot valve is subjected to pressure fluctuation and the pressure setting becomes unstable. For this reason, be sure to use external drain type valve.

##### ● Flow Adjustment

To perform the flow adjustment, loosen the lock nut, then turn the flow adjustment screw clockwise to decrease the flow. Be sure to re-tighten the lock nut after the adjustment.

##### ● Pressure Adjustment

To perform the pressure adjustment, loosen the lock nut, then turn the pressure adjustment screw clockwise to increase the pressure. Be sure to re-tighten the lock nut after the adjustment.

##### ● Min. Controlled Flow for Types "2" and "4A" at The Time of Metre-out Control

Minimum controlled flow at the time of metre-out control is limited (this does not happen during metre-in control) as shown in the figure below only in the case of pilot control types "2" (DSLHG-\*-2) and "4A" (DSLHG-\*-4A).

Min. Controlled Flow for Types "2" and "4A" at The Time of Metre-out Control

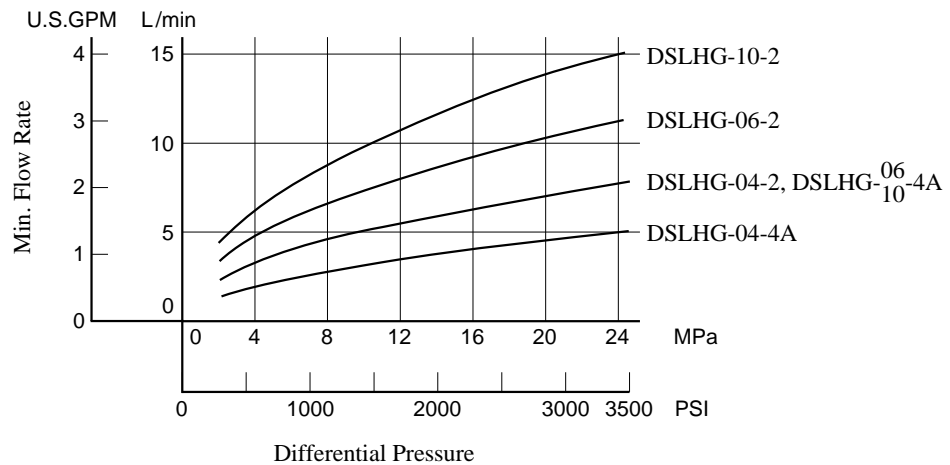

Hydraulic Fluid: Viscosity 35 mm<sup>2</sup>/s (164 SSU), Specific Gravity 0.850

#### ■ Pressure Drop

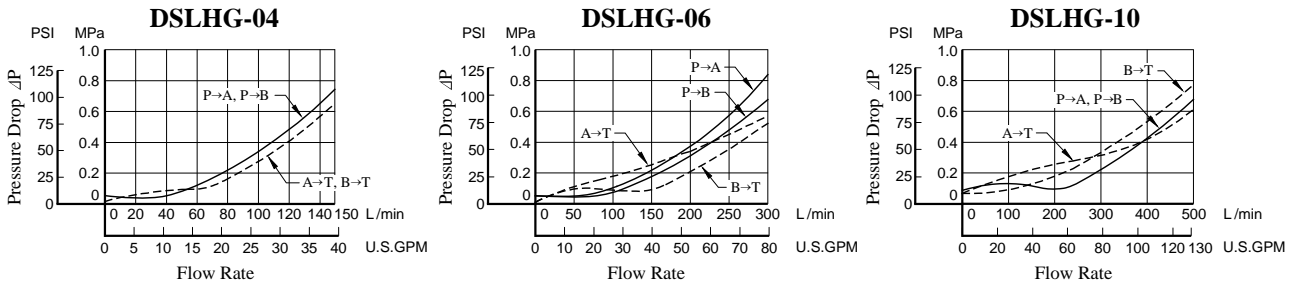

- For any other viscosity, multiply the factors in the table below.

Viscosity	mm <sup>2</sup> /s	15	20	30	40	50	60	70	80	90	100
	SSU		77	98	141	186	232	278	324	371	417
Factor		0.81	0.87	0.96	1.03	1.09	1.14	1.19	1.23	1.27	1.30

- For any other specific gravity (G'), the pressure drop (ΔP') may be obtained from the formula below.

$$\Delta P' = \Delta P (G'/0.850)$$

#### ■ Flow vs. Adjustment Revolutions

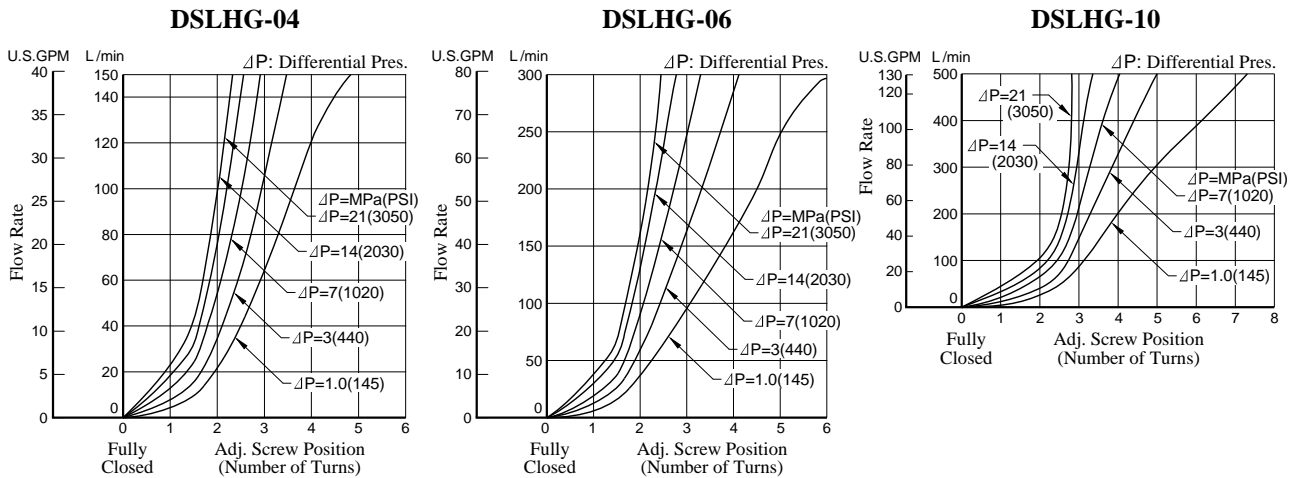

#### ■ Minimum Adjustment Pressure

Because the minimum adjustment pressure varies with the tank line back pressure, add the tank line back pressure to the value on the following lines.

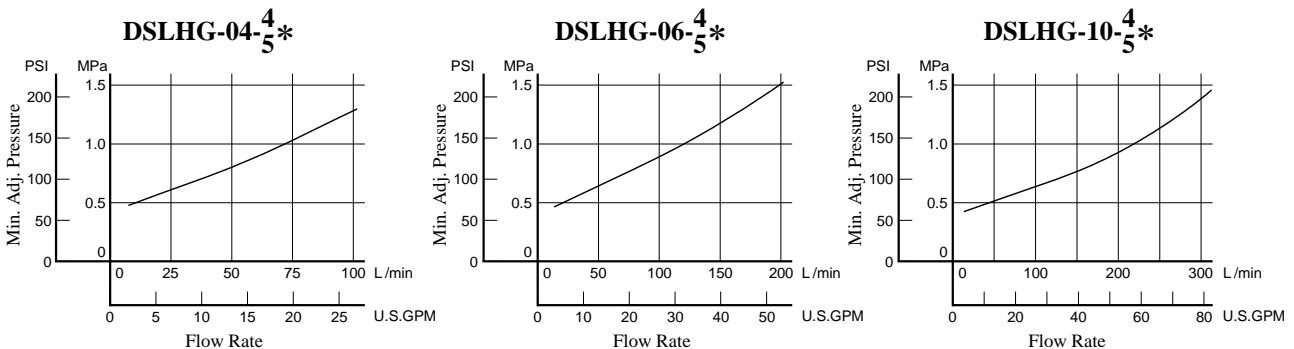



### Terminal Box Type

Mounting Surface:  
ISO 4401-AD-07-4-A

#### DSLHG-04- $\frac{1}{2}$ -\*-12/1290

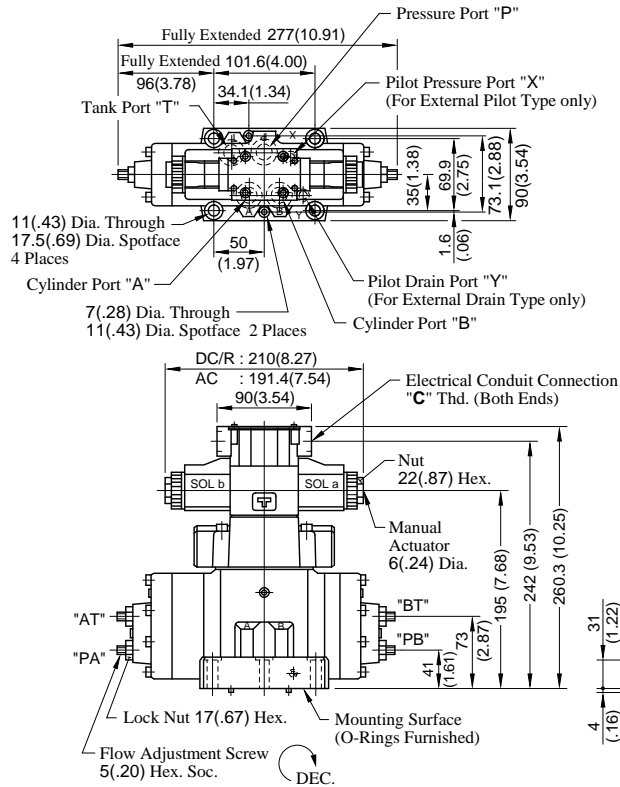

#### DSLHG-04-3-\*-12/1290

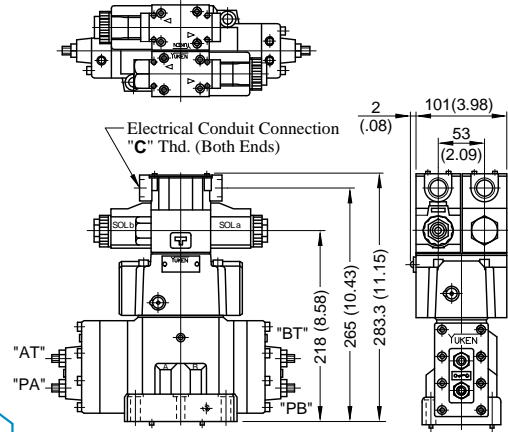

For other dimensions, see "DSLHG-04- $\frac{1}{2}$ " drawing left.

Model Numbers	"C" Thd.
DSLHG-04-*-12	G 1/2
DSLHG-04-*-1290	1/2 NPT

**DIMENSIONS IN  
MILLIMETRES (INCHES)**

#### DSLHG-04-4W-\*-12/1290

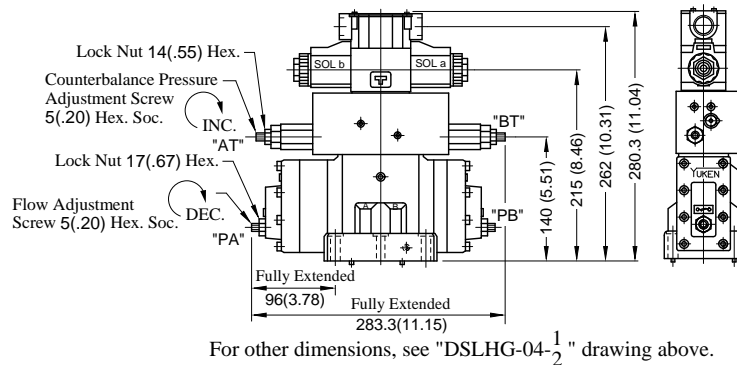

For other dimensions, see "DSLHG-04- $\frac{1}{2}$ " drawing above.

#### DSLHG-04-4A-\*-12/1290

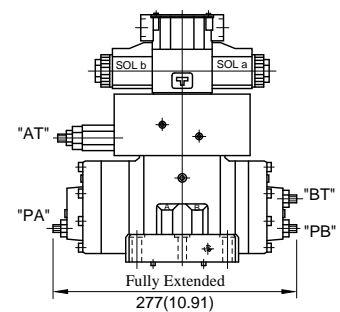

For other dimensions, see "DSLHG-04-4W" drawing left.

#### DSLHG-04-5W-\*-12/1290

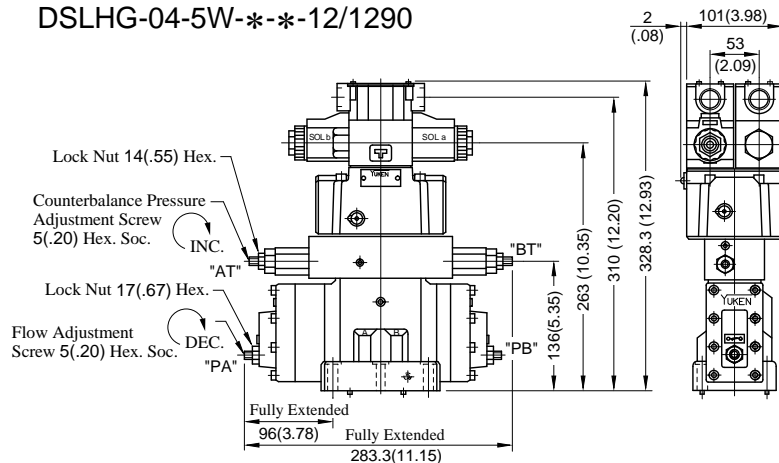

For other dimensions, see "DSLHG-04- $\frac{1}{2}$ " drawing above.

#### DSLHG-04-5A-\*-12/1290

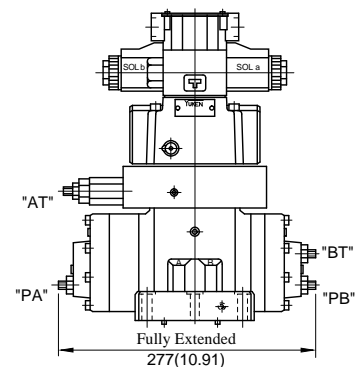

For other dimensions, see "DSLHG-04-5W" drawing left.



### Plug-in Connector Type

Mounting Surface:  
ISO 4401-AD-07-4-A

DSLHG-04- $\frac{1}{2}$ \*-N-12/1290

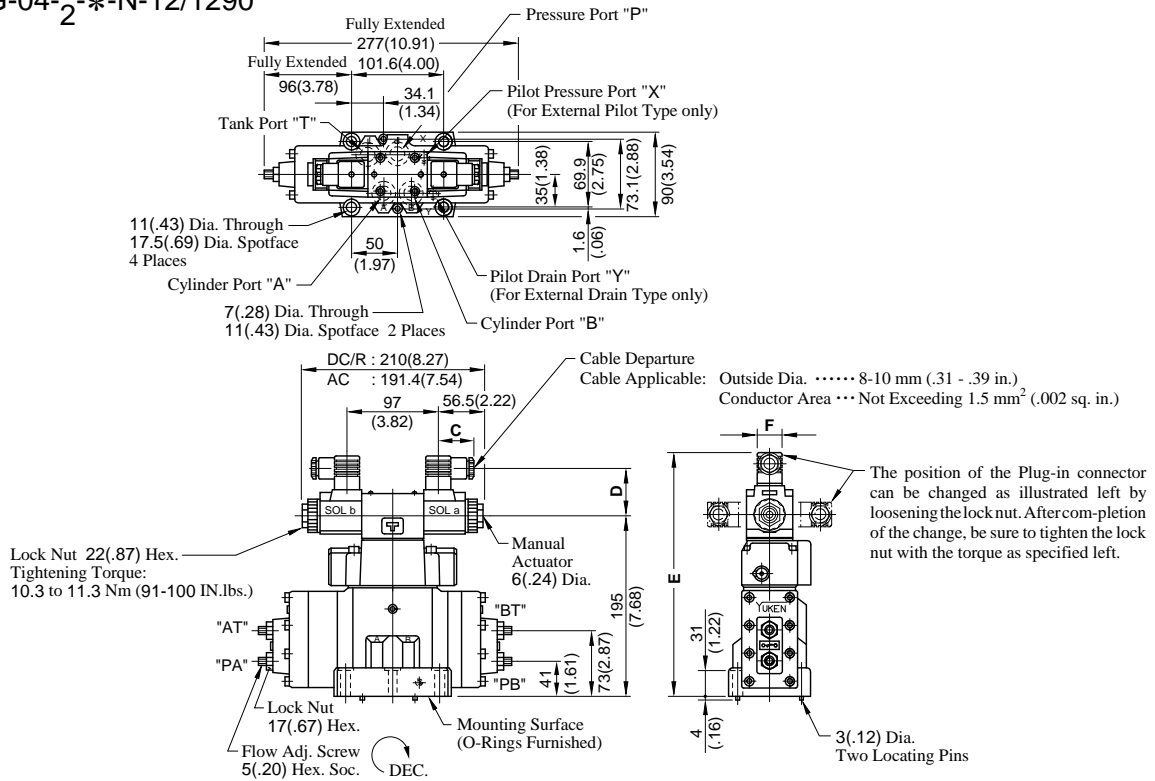

Model Numbers	Dimensions mm (Inches)			
	C	D	E	F
DSLHG-04*-A*-N	39 (1.54)	53 (2.09)	260 (10.24)	27.5 (1.08)
DSLHG-04*-D*-N	39 (1.54)	64 (2.52)	271 (10.67)	27.5 (1.08)
DSLHG-04*-R*-N	53 (2.09)	57.2 (2.25)	274 (10.79)	34 (1.34)

DSLHG-04-3\*-N-12/1290

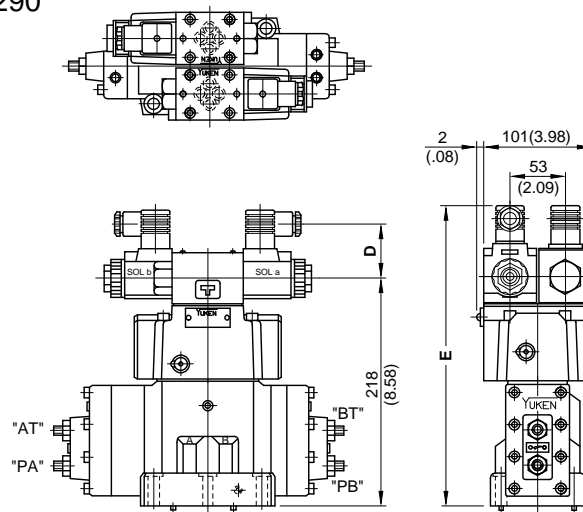

Model Numbers	Dimensions mm (Inches)	
	D	E
DSLHG-04-3-A*-N	53 (2.09)	283 (11.14)
DSLHG-04-3-D*-N	64 (2.52)	294 (11.57)
DSLHG-04-3-R*-N	57.2 (2.25)	297 (11.69)

**DIMENSIONS IN  
MILLIMETRES (INCHES)**

For other dimensions, see "DSLHG-04- $\frac{1}{2}$ \*-N" drawing above.

### Plug-in Connector Type

Mounting Surface:  
ISO 4401-AD-07-4-A

#### DSLHG-04-4W-\*-N-12/1290

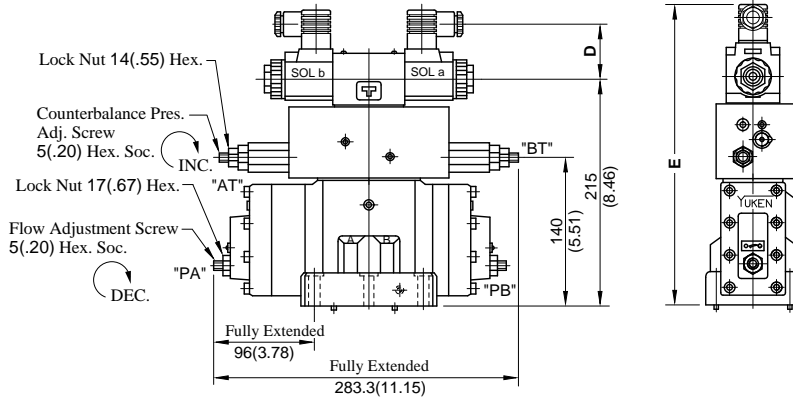

Model Numbers	Dimensions mm (Inches)	
	D	E
DSLHG-04-4W-*-A*-N	53 (2.09)	280 (11.02)
DSLHG-04-4W-*-D*-N	64 (2.52)	291 (11.46)
DSLHG-04-4W-*-R*-N	57.2 (2.25)	294 (11.57)

For other dimensions, see DSLHG-04- $\frac{1}{2}$ -\*-N on the previous page.

#### DSLHG-04-4A-\*-N-12/1290

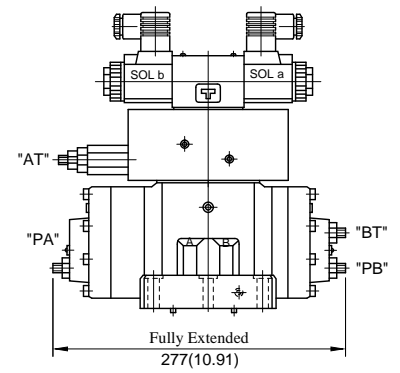

For other dimensions, see  
"DSLHG-04-4W-\*-N" drawing left.

#### DSLHG-04-5W-\*-N-12/1290

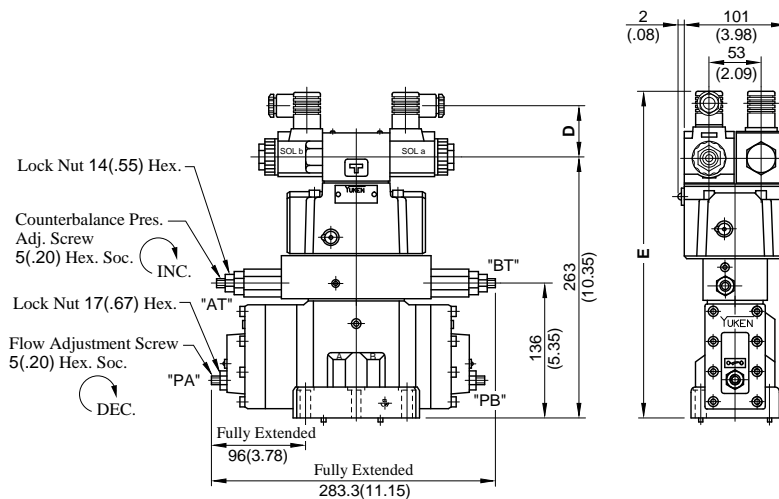

Model Numbers	Dimensions mm (Inches)	
	D	E
DSLHG-04-5W-*-A*-N	53 (2.09)	328 (12.91)
DSLHG-04-5W-*-D*-N	64 (2.52)	339 (13.35)
DSLHG-04-5W-*-R*-N	57.2 (2.25)	342 (13.46)

For other dimensions, see DSLHG-04- $\frac{1}{2}$ -\*-N on the previous page.

#### DSLHG-04-5A-\*-N-12/1290

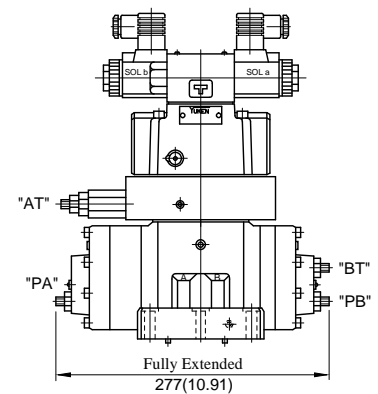

For other dimensions, see  
"DSLHG-04-5W-\*-N" drawing left.

**DIMENSIONS IN  
MILLIMETRES (INCHES)**

### Terminal Box Type

Mounting Surface:  
ISO 4401-AE-08-4-A

#### DSLHG-06-1/2-\*12/1290

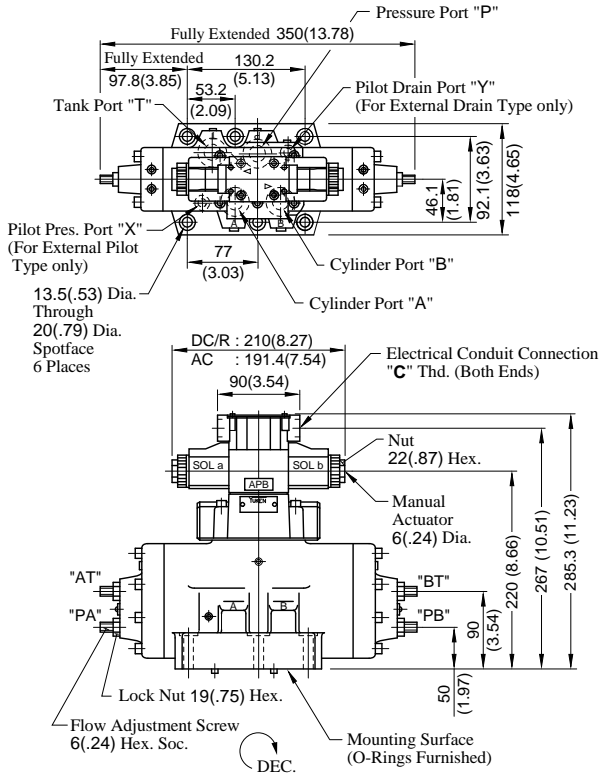

#### DSLHG-06-3-\*12/1290

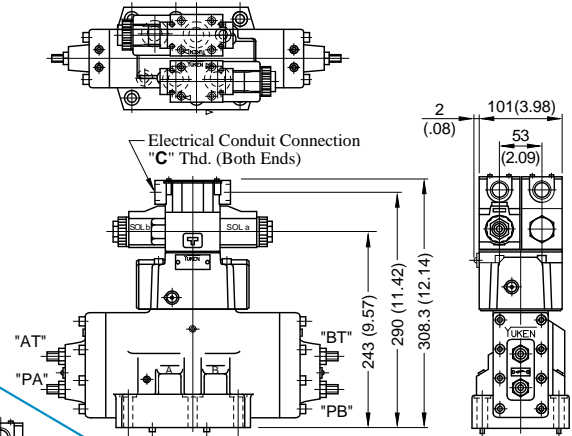

For other dimensions, see "DSLHG-06-1/2" drawing left.

Model Numbers	"C" Thd.
DSLHG-06-***-12	G 1/2
DSLHG-06-***-1290	1/2 NPT

**DIMENSIONS IN MILLIMETRES (INCHES)**

#### DSLHG-06-4W-\*12/1290

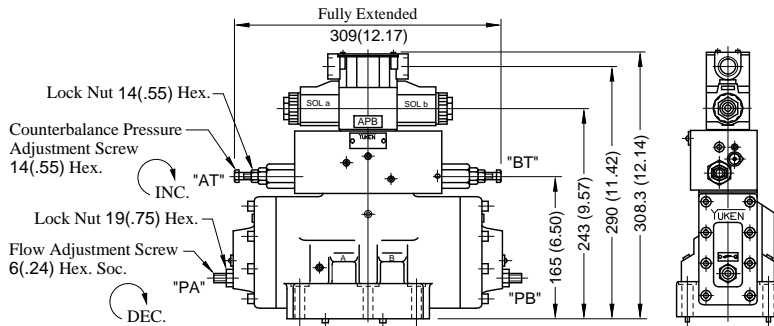

For other dimensions, see "DSLHG-06-1/2" drawing above.

#### DSLHG-06-4A-\*12/1290

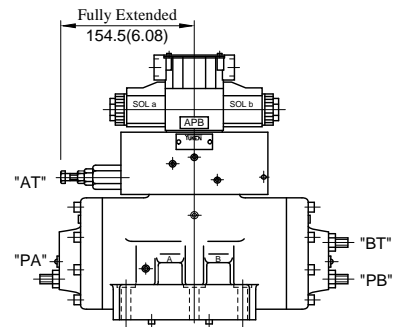

For other dimensions, see "DSLHG-06-4W" drawing left.

#### DSLHG-06-5W-\*12/1290

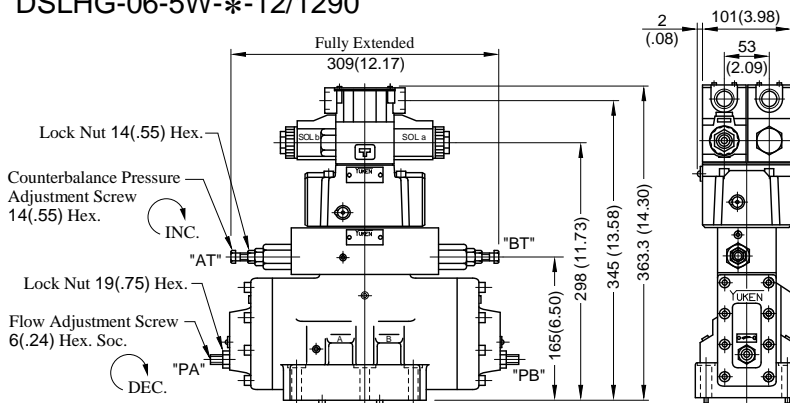

For other dimensions, see "DSLHG-06-1/2" drawing above.

#### DSLHG-06-5A-\*12/1290

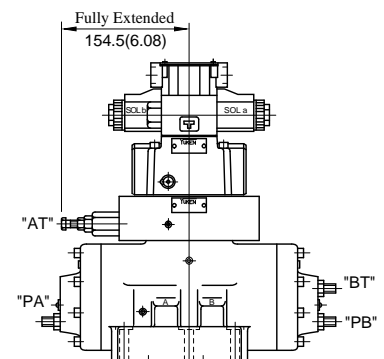

For other dimensions, see "DSLHG-06-5W" drawing left.

### Plug-in Connector Type

DSLHG-06- $\frac{1}{2}$ -\*-N-12/1290

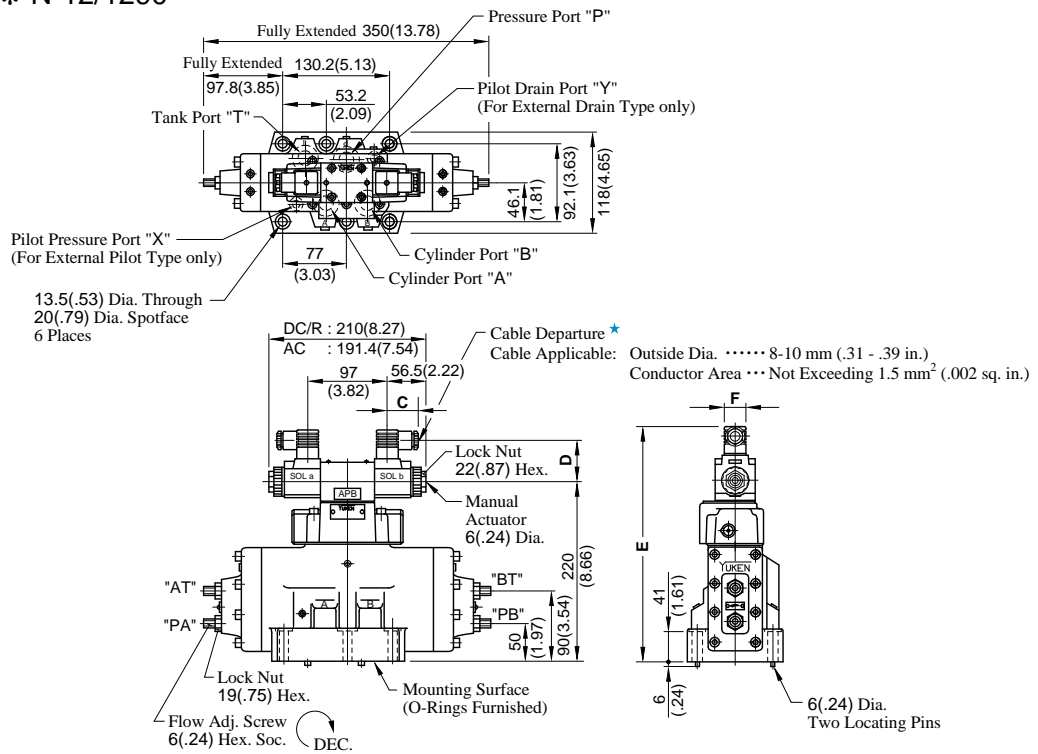

Model Numbers	Dimensions mm (Inches)			
	C	D	E	F
DSLHG-06-*-A*-N	39 (1.54)	53 (2.09)	285 (11.22)	27.5 (1.08)
DSLHG-06-*-D*-N	39 (1.54)	64 (2.52)	296 (11.65)	27.5 (1.08)
DSLHG-06-*-R*-N	53 (2.09)	57.2 (2.25)	299 (11.77)	34 (1.34)

★ Position of cable departure can be changed. For the details, refer to DSLHG-04 valve on page 9.

DSLHG-06-3-\*-N-12/1290

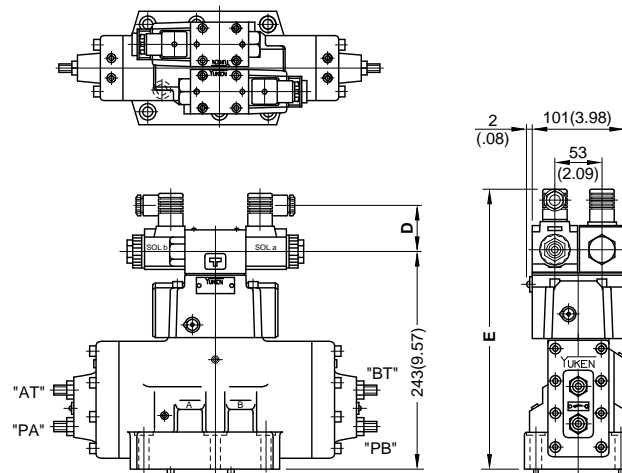

Model Numbers	Dimensions mm (Inches)	
	D	E
DSLHG-06-3-A*-N	53 (2.09)	308 (12.13)
DSLHG-06-3-D*-N	64 (2.52)	319 (12.56)
DSLHG-06-3-R*-N	57.2 (2.25)	322 (12.68)

**DIMENSIONS IN  
MILLIMETRES (INCHES)**

For other dimensions, see "DSLHG-06- $\frac{1}{2}$ -\*-N" drawing above.

### Plug-in Connector Type

Mounting Surface:  
ISO 4401-AE-08-4-A

#### DSLHG-06-4W-\*-N-12/1290

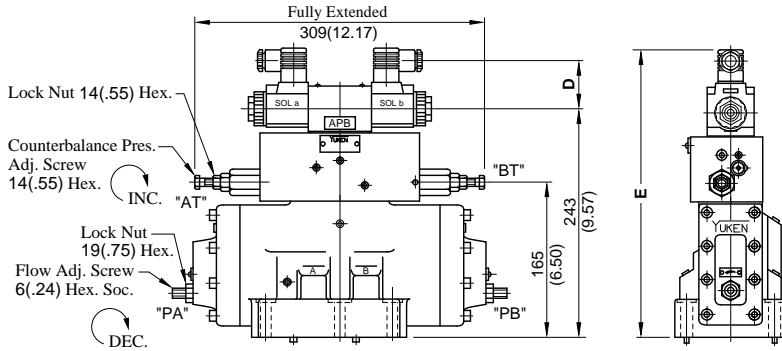

Model Numbers	Dimensions mm (Inches)	
	D	E
DSLHG-06-4W-A*-N	53 (2.09)	308 (12.13)
DSLHG-06-4W-D*-N	64 (2.52)	319 (12.56)
DSLHG-06-4W-R*-N	57.2 (2.25)	322 (12.68)

For other dimensions, see DSLHG-06- $\frac{1}{2}$ -\*-N on the previous page.

#### DSLHG-06-4A-\*-N-12/1290

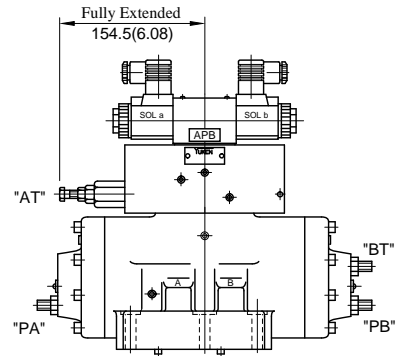

For other dimensions, see "DSLHG-06-4W-\*-N" drawing left.

E

#### DSLHG-06-5W-\*-N-12/1290

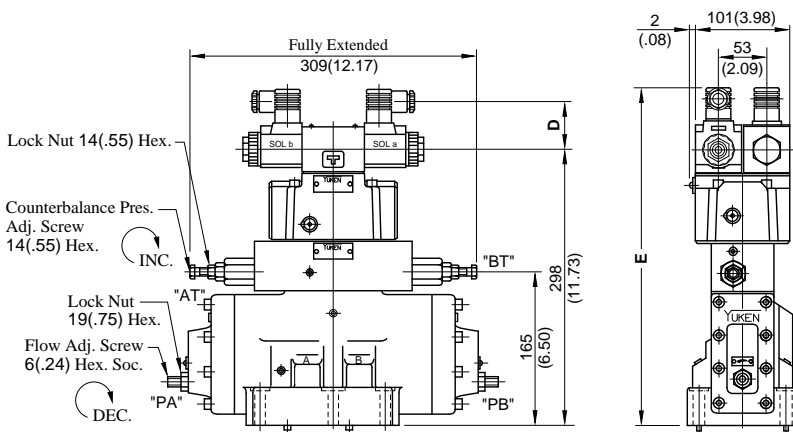

Model Numbers	Dimensions mm (Inches)	
	D	E
DSLHG-06-5W-A*-N	53 (2.09)	363 (14.29)
DSLHG-06-5W-D*-N	64 (2.52)	374 (14.72)
DSLHG-06-5W-R*-N	57.2 (2.25)	377 (14.84)

For other dimensions, see DSLHG-06- $\frac{1}{2}$ -\*-N on the previous page.

#### DSLHG-06-5A-\*-N-12/1290

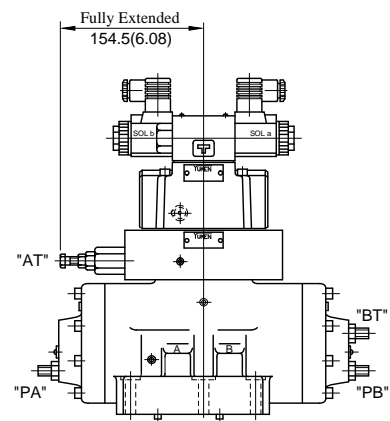

For other dimensions, see "DSLHG-06-5W-\*-N" drawing left.

DIMENSIONS IN  
MILLIMETRES (INCHES)

### Terminal Box Type

Mounting Surface:  
ISO 4401-AF-10-4-A

#### DSLHG-10- $\frac{1}{2}$ -\*-12/1290

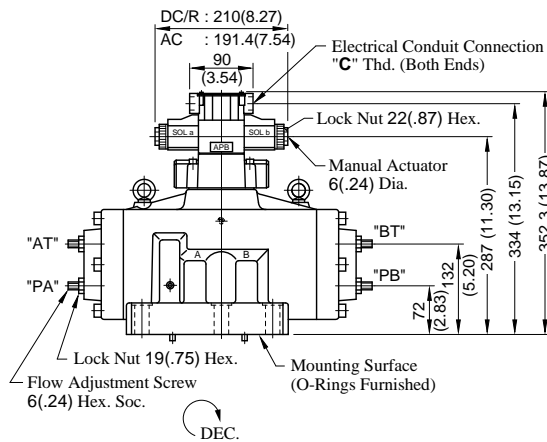
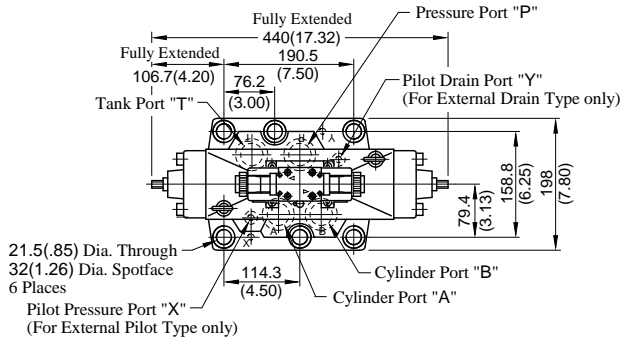

#### DSLHG-10-3-\*-12/1290

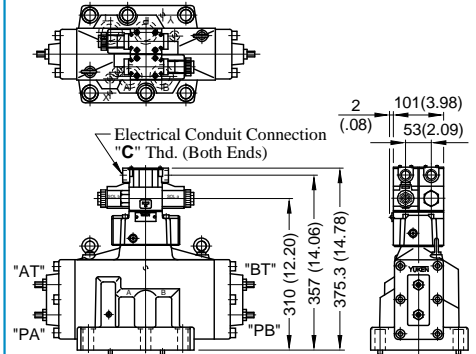

For other dimensions, see "DSLHG-10- $\frac{1}{2}$ " drawing left.

Model Numbers	"C" Thd.
DSLHG-10-*-*-12	G 1/2
DSLHG-10-*-*-1290	1/2 NPT

**DIMENSIONS IN  
MILLIMETRES (INCHES)**

#### DSLHG-10-4W-\*-12/1290

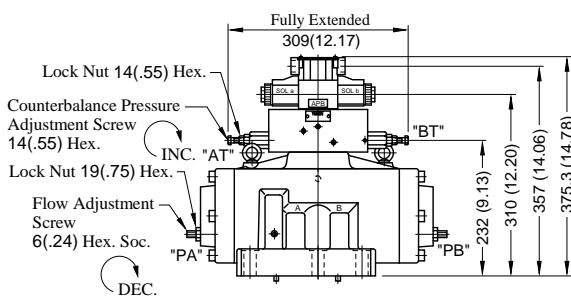

For other dimensions, see "DSLHG-10- $\frac{1}{2}$ " drawing above.

#### DSLHG-10-4A-\*-12/1290

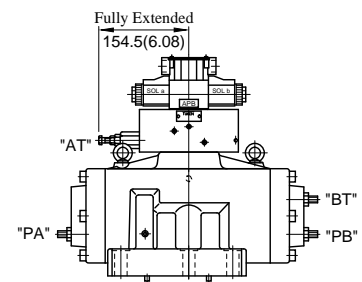

For other dimensions, see "DSLHG-10-4W" drawing left.

#### DSLHG-10-5W-\*-12/1290

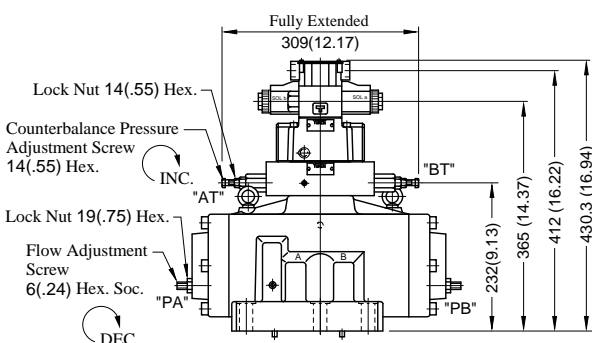

For other dimensions, see "DSLHG-10- $\frac{1}{2}$ " drawing above.

#### DSLHG-10-5A-\*-12/1290

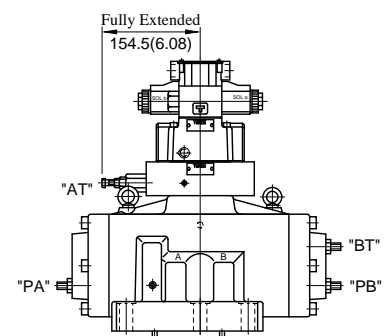

For other dimensions, see "DSLHG-10-5W" drawing left.

### Plug-in Connector Type

DSLHG-10- $\frac{1}{2}$ -\*-N-12/1290

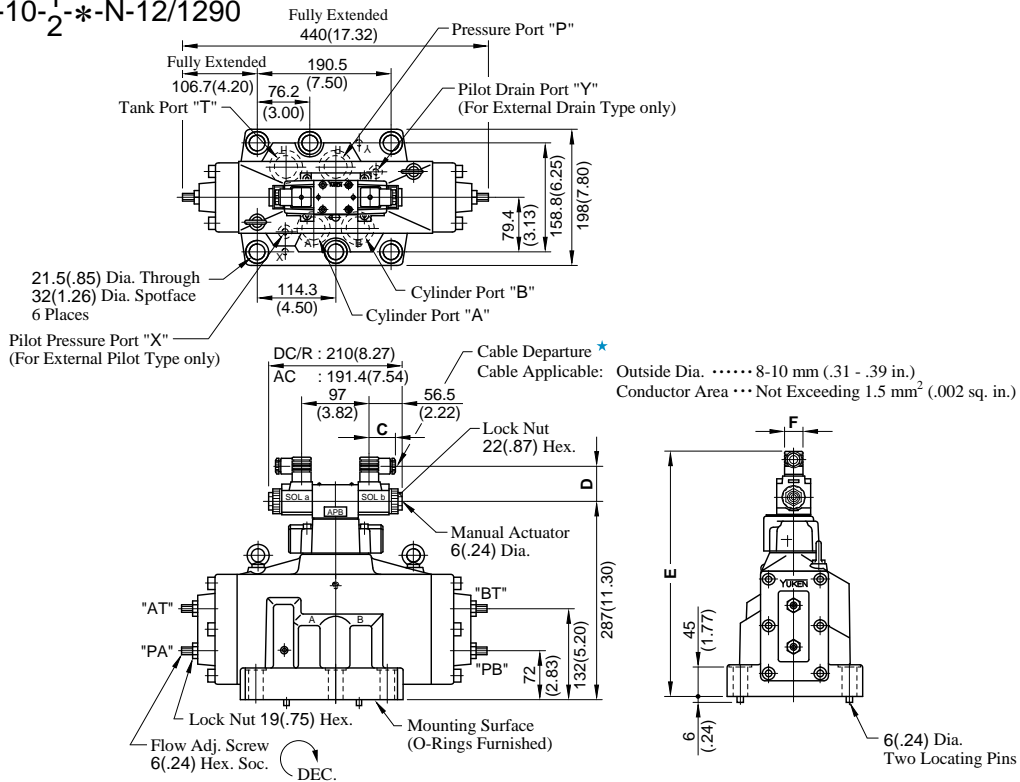

Model Numbers	Dimensions mm (Inches)			
	C	D	E	F
DSLHG-10-*-A*-N	39 (1.54)	53 (2.09)	352 (13.86)	27.5 (1.08)
DSLHG-10-*-D*-N	39 (1.54)	64 (2.52)	363 (14.29)	27.5 (1.08)
DSLHG-10-*-R*-N	53 (2.09)	57.2 (2.25)	366 (14.41)	34 (1.34)

★ Position of cable departure can be changed. For the details, refer to DSLHG-04 valve on page 9.

DSLHG-10-3-\*-N-12/1290

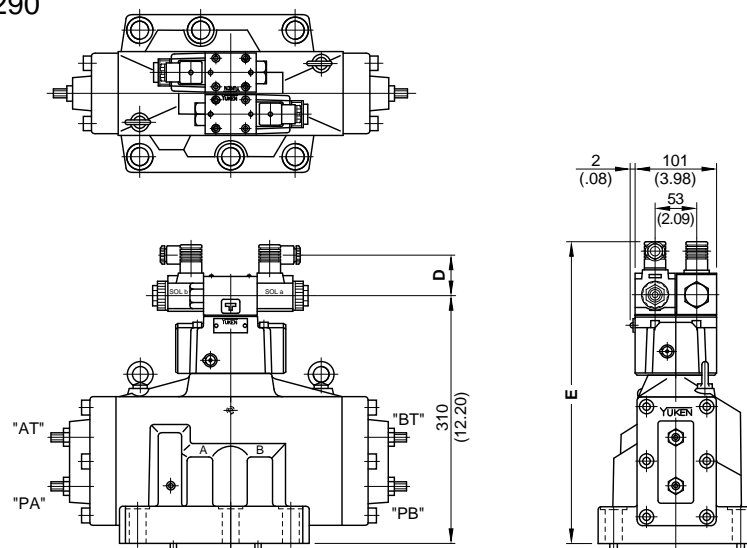

Model Numbers	Dimensions mm (Inches)	
	D	E
DSLHG-10-3-A*-N	53 (2.09)	375 (14.76)
DSLHG-10-3-D*-N	64 (2.52)	386 (15.20)
DSLHG-10-3-R*-N	57.2 (2.25)	389 (15.31)

DIMENSIONS IN  
MILLIMETRES (INCHES)

For other dimensions, see "DSLHG-10- $\frac{1}{2}$ -\*-N" drawing above.



### Plug-in Connector Type

Mounting Surface:  
ISO 4401-AF-10-4-A

#### DSLHG-10-4W-\*-N-12/1290

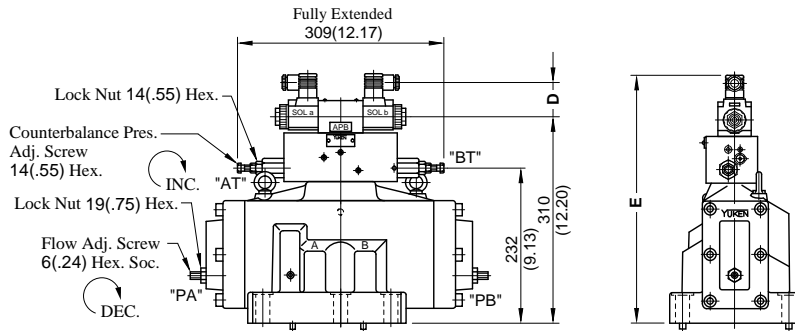

Model Numbers	Dimensions mm (Inches)	
	D	E
DSLHG-10-4W-A*-N	53 (2.09)	375 (14.76)
DSLHG-10-4W-D*-N	64 (2.52)	386 (15.20)
DSLHG-10-4W-R*-N	57.2 (2.25)	389 (15.31)

For other dimensions, see DSLHG-10- $\frac{1}{2}$ -\*-N on the previous page.

#### DSLHG-10-4A-\*-N-12/1290

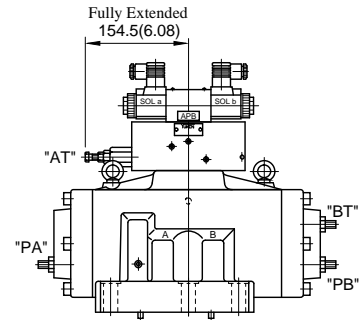

For other dimensions, see  
"DSLHG-10-4W-\*-N" drawing left.

#### DSLHG-10-5W-\*-N-12/1290

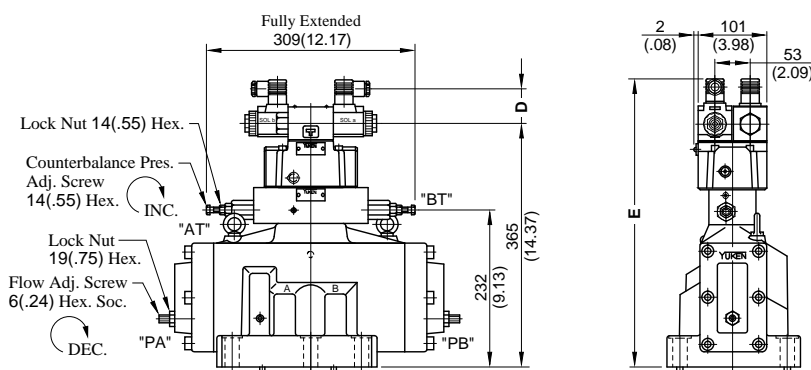

Model Numbers	Dimensions mm (Inches)	
	D	E
DSLHG-10-5W-A*-N	53 (2.09)	430 (16.93)
DSLHG-10-5W-D*-N	64 (2.52)	441 (17.36)
DSLHG-10-5W-R*-N	57.2 (2.25)	444 (17.48)

For other dimensions, see DSLHG-10- $\frac{1}{2}$ -\*-N on the previous page.

#### DSLHG-10-5A-\*-N-12/1290

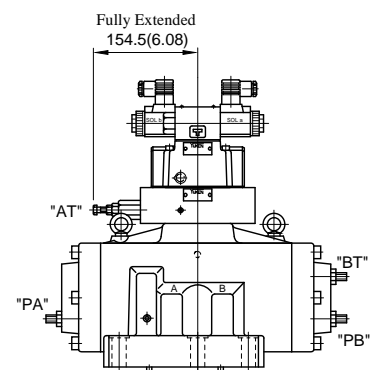

For other dimensions, see  
"DSLHG-10-5W-\*-N" drawing left.

**DIMENSIONS IN  
MILLIMETRES (INCHES)**

● DHGM-04-20/2080/2090  
04X

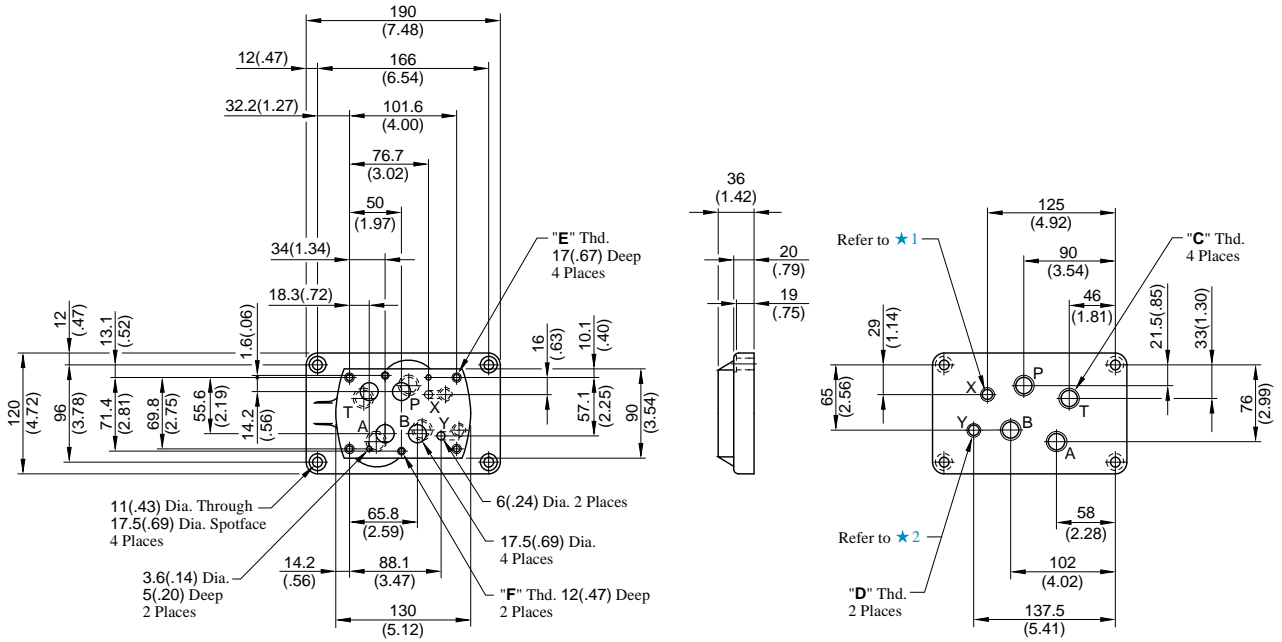

- ★ 1. Used only on external pilot type valves. To be plugged on internal pilot type valves.
- ★ 2. Used only on external drain type valves. To be plugged on internal drain type valves.

**DIMENSIONS IN MILLIMETRES (INCHES)**

Sub-plate Model Numbers	"C" Thd.	"D" Thd.	"E" Thd.	"F" Thd.
DHGM-04-20	Rc 1/2	Rc 1/4	M10	M6
DHGM-04X-20	Rc 3/4			
DHGM-04-2080	1/2 BSP.F	1/4 BSP.F	M10	M6
DHGM-04X-2080	3/4 BSP.F			
DHGM-04-2090	1/2 NPT	1/4 NPT	3/8-16 UNC	1/4-20 UNC
DHGM-04X-2090	3/4 NPT			

#### ● DHGM-06-06X-50/5090

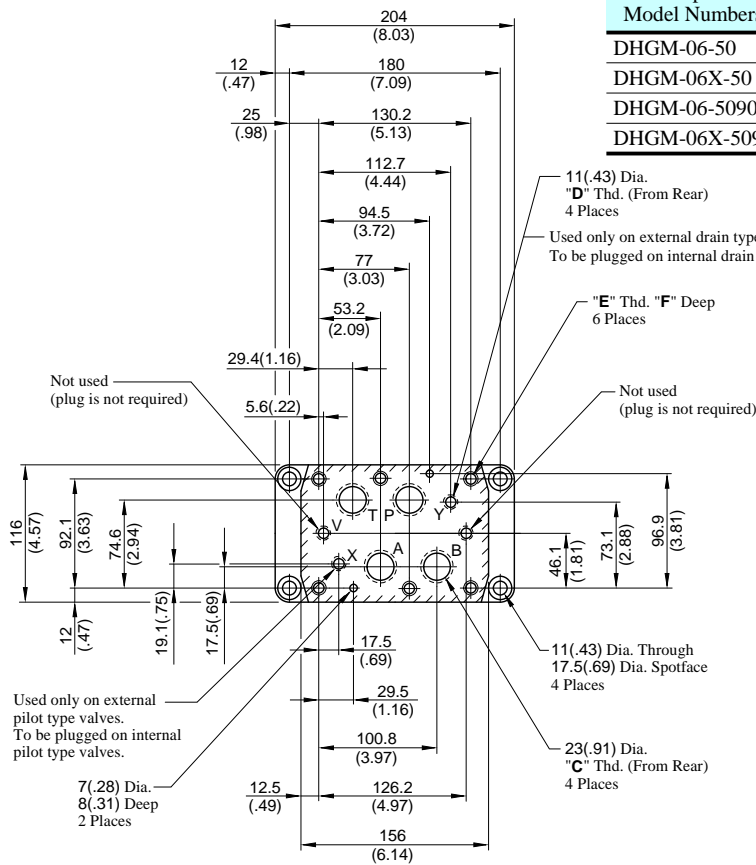

Sub-plate Model Numbers	"C" Thd.	"D" Thd.	"E" Thd.	F mm (in.)
DHGM-06-50	Rc 3/4	Rc 1/4	M12	24 (.94)
DHGM-06X-50	Rc 1			
DHGM-06-5090	3/4 NPT	1/4 NPT	1/2-13 UNC	26 (1.02)
DHGM-06X-5090	1 NPT			

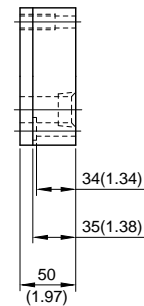

**DIMENSIONS IN MILLIMETRES (INCHES)**

#### ● DHGM-06-06X-5080

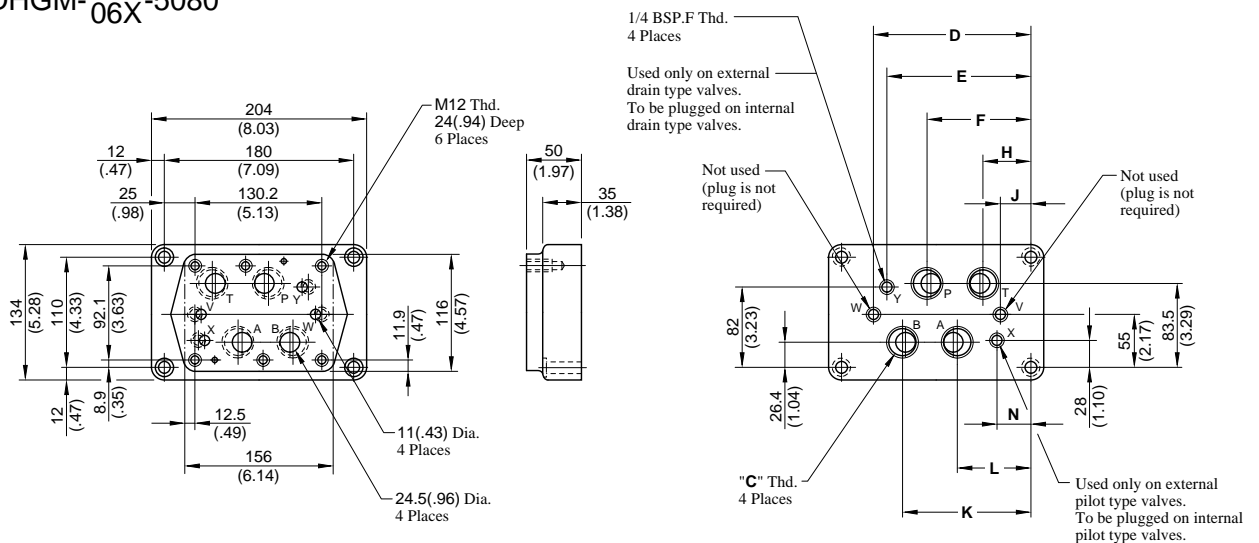

Sub-plate Model Numbers	"C" Thd.	Dimensions mm (Inches)							
		D	E	F	H	J	K	L	N
DHGM-06-5080	3/4 BSP.F	151.2 (5.95)	137.7 (5.42)	102 (4.02)	54.4 (2.14)	30.6 (1.20)	125.8 (4.95)	78.2 (3.08)	42.5 (1.67)
DHGM-06X-5080	1 BSP.F	155.2 (6.11)	148 (5.83)	106 (4.17)	50 (1.97)	25 (.98)	130 (5.12)	74 (2.91)	32 (1.26)

For other dimensions, refer to "DHGM-06\*-50/5090" above.

● DHGM-10<sup>10</sup>X-40/4080/4090

DIMENSIONS IN MILLIMETRES (INCHES)

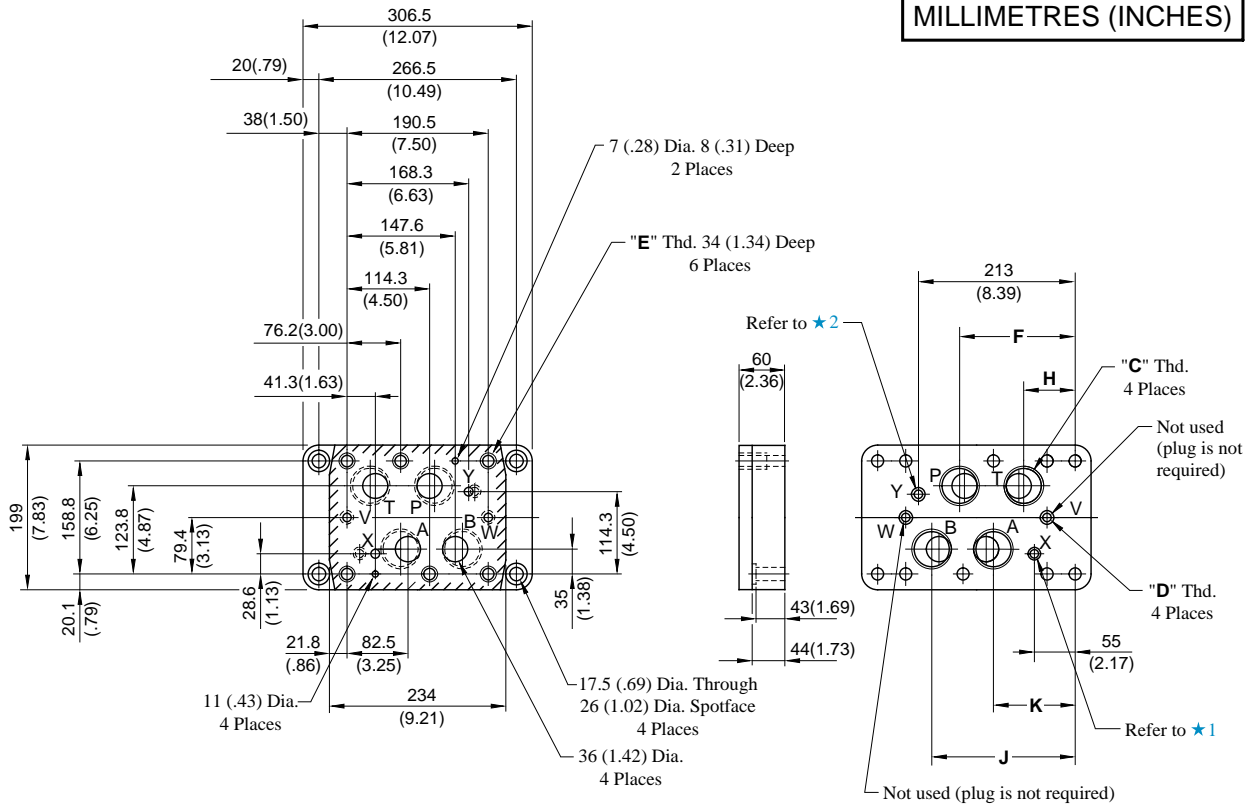

Sub-plate Model Numbers	"C" Thd.	"D" Thd.	"E" Thd.	Dimensions mm (Inches)			
				F	H	J	K
DHGM-10-40	Rc 1-1/4	Rc 3/8	M20	152 (5.98)	79 (3.11)	185.5 (7.30)	120.5 (4.74)
DHGM-10-4080	1-1/4 BSP.F	3/8 BSP.F	M20				
DHGM-10-4090	1-1/4 NPT	3/8 NPT	3/4-10 UNC				
DHGM-10X-40	Rc 1-1/2	Rc 3/8	M20	156 (6.14)	74 (2.91)	194.5 (7.66)	112.5 (4.43)
DHGM-10X-4080	1-1/2 BSP.F	3/8 BSP.F	M20				
DHGM-10X-4090	1-1/2 NPT	3/8 NPT	3/4-10 UNC				

- ★ 1. Used only on external pilot type valves. To be plugged on internal pilot type valves.
- ★ 2. Used only on external drain type valves. To be plugged on internal drain type valves.



DSLHG-04/06/10-<sup>1</sup>/<sub>2</sub>-\*-12/1290

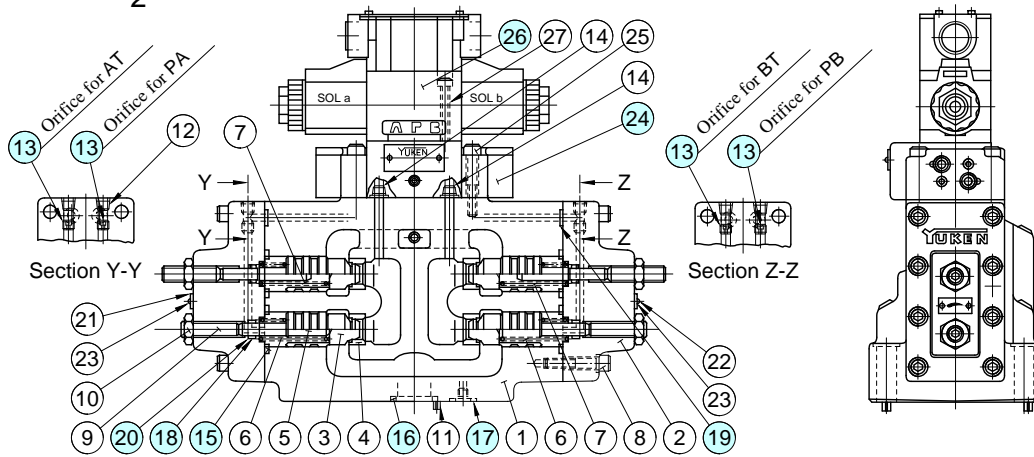

DSLHG-04/06/10-3-\*-12/1290

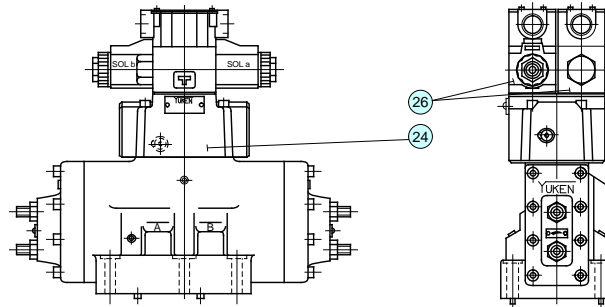

Note) Main valve is same as above drawings.

#### ● List of Seals for Main Valves

Item	Name of Parts	Part Numbers			Qty.
		DSLHG-04	DSLHG-06	DSLHG-10	
15	O-Ring	SO-NB-P22	SO-NB-G30	SO-NB-G40	4
16	O-Ring	SO-NB-P22	SO-NB-P30	SO-NB-P42	4
17	O-Ring	SO-NB-P9	SO-NB-P14	SO-NB-P14	2
18	O-Ring	SO-NA-P8	SO-NA-P10	SO-NA-P16	4
19	O-Ring	SO-NB-P8	SO-NB-P9	SO-NB-P11	4
20	Back Up Ring	SO-BB-P8	SO-BB-P10	SO-BB-P16	4

Note: When ordering the seals, please specify the seal kit number listed on page 24.

#### ● Item 13 Orifice

The timing of flow path opening/closing can be adjusted as required by selecting the appropriate pilot orifice diameter. When the diameter of the orifice is to be changed, another orifice should be ordered. Standard built-in orifice diameters and selectable orifice diameters are listed in the table below.

Orifice Type	TP-OPT-1/16 x d		
	Orifice Diameter "d" mm		
Model Numbers	Standard Built-in	Selectable	Max. Dia. at Pressure over 20 MPa(2900 PSI)
DSLHG-04	1.0	0.5, 0.6, 0.8, 1.0	1.2
DSLHG-06	1.2	1.2, 1.4, 1.6, 1.8	
DSLHG-10	1.4	2.0, 2.5	1.4

#### ● Item 24 Pilot Selector Valve List

Multi-Purpose Control Valve Model Numbers	24 Pilot Selector Valve Model Numbers
DSLHG-04-1	CG-04-1-10
DSLHG-04-2	CG-04-2-10
DSLHG-04-3	CG-04-3-10
DSLHG-06-1	CG-06-1-10
DSLHG-06-2	CG-06-2-10
DSLHG-06-3	CG-06-3-10
DSLHG-10-1	CG-06-1-10
DSLHG-10-2	CG-06-2-10
DSLHG-10-3	CG-06-3-10

Note: For details of Pilot Selector Valve, see page 22.

#### ● Pilot Valve

Refer to page 24 for Pilot Valve Model Numbers.

#### ⚠ CAUTION

When making replacement of seals, pilot valve, pilot selector valves or other parts, please do it carefully after reading through the relevant instructions in the Operator's Manual.

#### DSLHG-04/06/10-4W-\*-12/1290

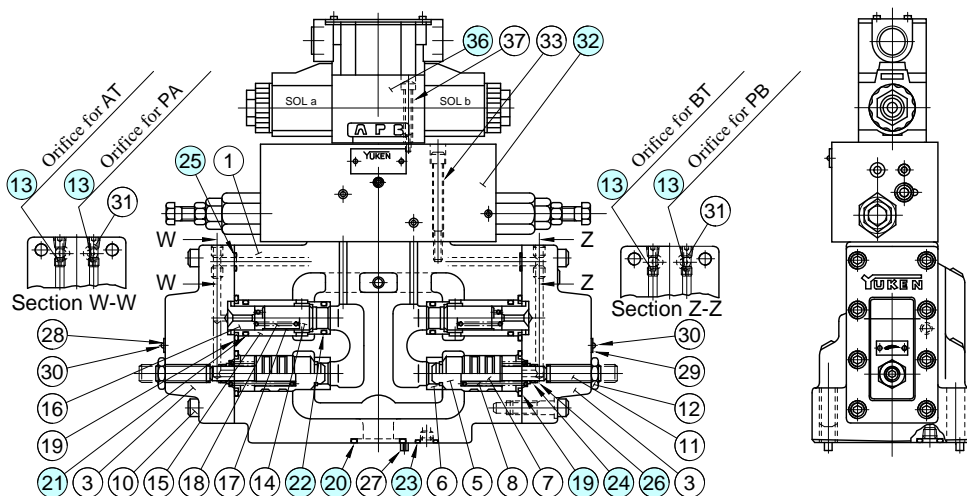

#### DSLHG-04/06/10-4A 5A-\*-12/1290

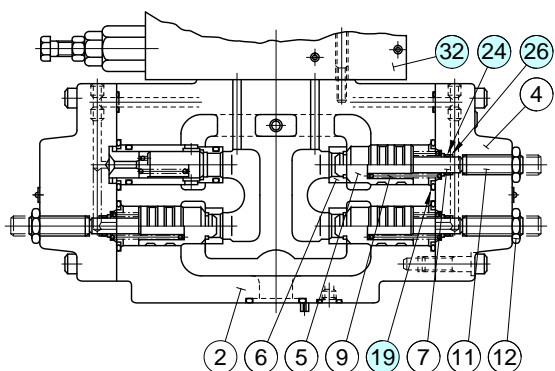

#### DSLHG-04/06/10-5W-\*-12/1290

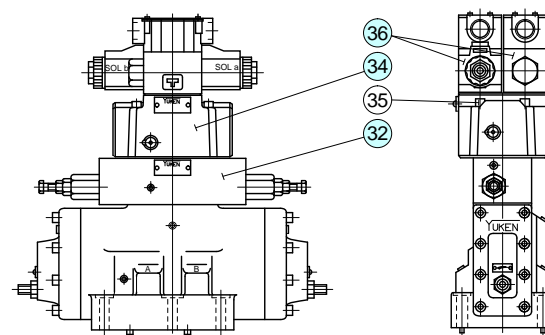

Note) Main valve is the same as above drawings.

#### ● List of Seals for Main Valves

Item	Name of Parts	Part Numbers			Qty.
		DSLHG-04	DSLHG-06	DSLHG-10	
19	O-Ring	SO-NB-P22	SO-NB-G30	SO-NB-G40	4
20	O-Ring	SO-NB-P22	SO-NB-P30	SO-NB-P42	4
21	O-Ring	SO-NB-P16	SO-NB-P22	SO-NB-P30	2(1)
22	O-Ring	SO-NB-P14	SO-NB-P20	SO-NB-	2(1)
23	O-Ring	SO-NB-P9	SO-NB-P14	A122	2
24	O-Ring	SO-NA-P8	SO-NA-P10	SO-NB-P14	2(3)
25	O-Ring	SO-NB-P8	SO-NB-P9	SO-NA-P16	4
26	Back Up Ring	SO-BB-P8	SO-BB-P10	SO-NB-P11	2(3)

Note 1: The figures in ( ) indicate the quantity of seals used for 4A and 5A.

Note 2: When ordering the seals, please specify the seal kit number listed on page 24.

#### ● Pilot Valve

Refer to page 24 for Pilot Valve Model Numbers.

#### ● Pilot Selector Valve List

Multi-Purpose Control Valve Model Numbers	Pilot Selector Valve Model Numbers	
	Item (32)	Item (34)
DSLHG-04-4A-■	CG-04-4A-■-10	—
DSLHG-04-4W-■	CG-04-4W-■-10	—
DSLHG-04-5A-■	CG-04-5A-■-10	CG-04-3-10
DSLHG-04-5W-■	CG-04-5W-■-10	
DSLHG-06-4A	CG-06-4A-10	—
DSLHG-06-4W	CG-06-4W-10	—
DSLHG-06-5A	CG-06-5A-10	CG-06-3-10
DSLHG-06-5W	CG-06-5W-10	
DSLHG-10-4A	CG-06-4A-10	—
DSLHG-10-4W	CG-06-4W-10	—
DSLHG-10-5A	CG-06-5A-10	CG-06-3-10
DSLHG-10-5W	CG-06-5W-10	

Note: Fill "B" or "H" representing the pressure adjustment range in section marked with ■.

See page 23 for the details of the pilot selector valves.



#### CAUTION

When making replacement of seals, pilot valves, pilot selector valves or other parts, please do it carefully after reading through the relevant instructions in the Operator's Manual.

● See the previous page for Item (13) Orifice.



**CAUTION**

When making replacement of seals, please do it carefully after reading through the relevant instructions in the Operator's Manual.

#### CG-04/06-1-10

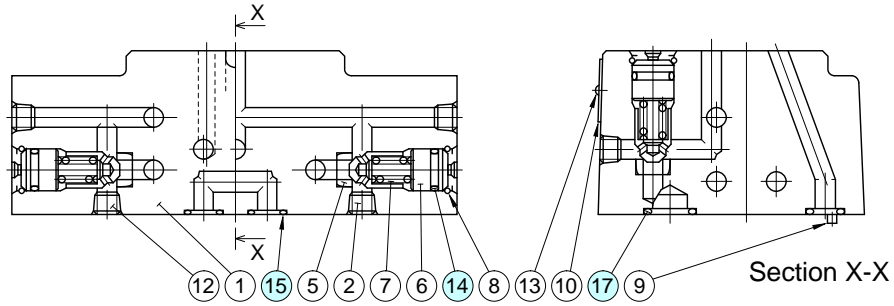

#### CG-04/06-2-10

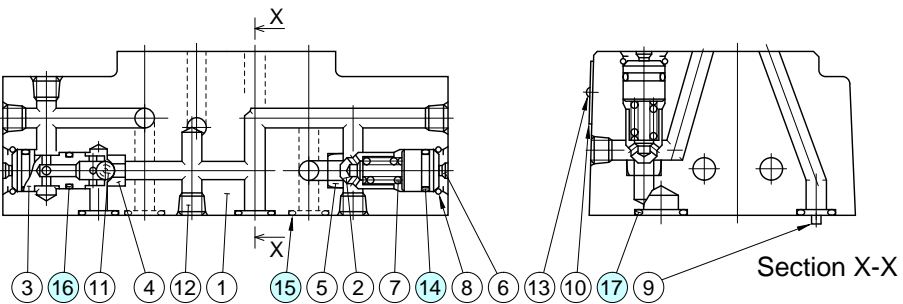

#### CG-04/06-3-10

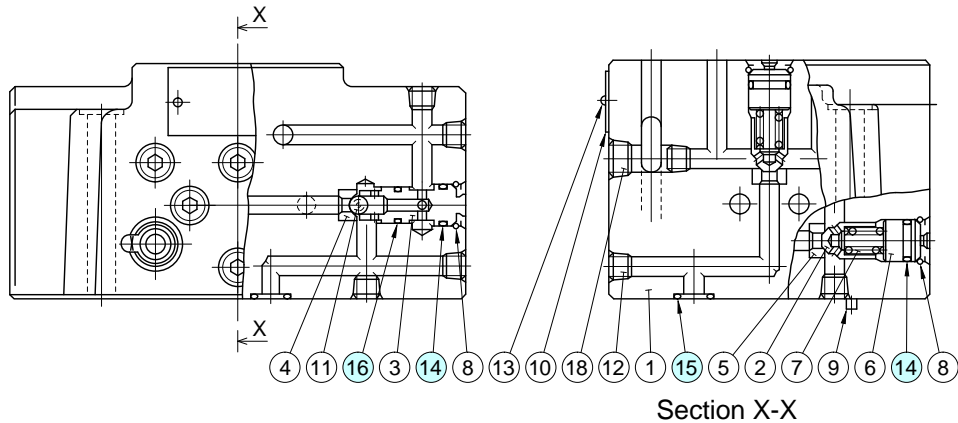

● List of Seals

Item	Name of Parts	CG-04					CG-06			
		Part Numbers	Quantity			Part Numbers	Quantity			
			CG-04-1	CG-04-2	CG-04-3		CG-06-1	CG-06-2	CG-06-3	
14	O-Ring	SO-NB-P10	3	5	5	SO-NB-P10	3	5	5	
15	O-Ring	SO-NB-P8	7	7	8	SO-NB-P9	7	7	8	
16	O-Ring	SO-NB-P8	—	2	2	SO-NB-P8	—	2	2	
17	O-Ring	SO-NB-P8	1	1	—	SO-NB-A014	1	1	—	

Note: When ordering the o-rings, please specify the seal kit number listed in page 24.



**CAUTION**

When making replacement of seals, please do it carefully after reading through the relevant instructions in the Operator's Manual.

#### CG-04/06-4W-10

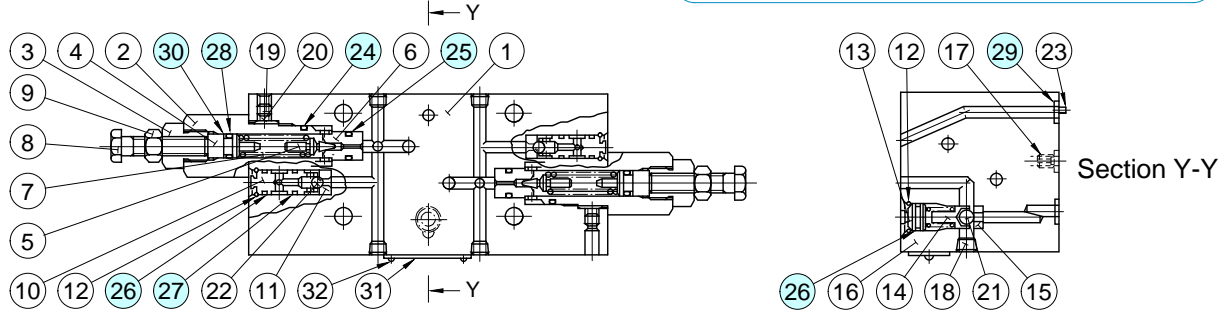

#### CG-04/06-4A-10

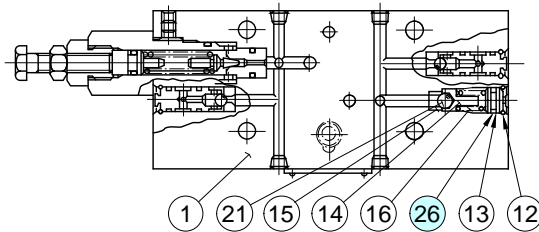

#### CG-04/06-5A-10

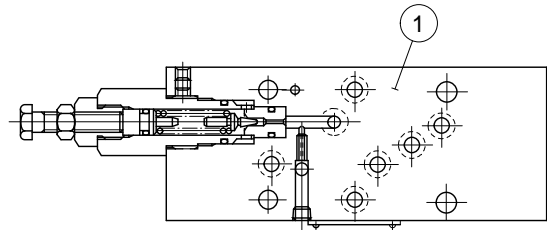

#### CG-04/06-5W-10

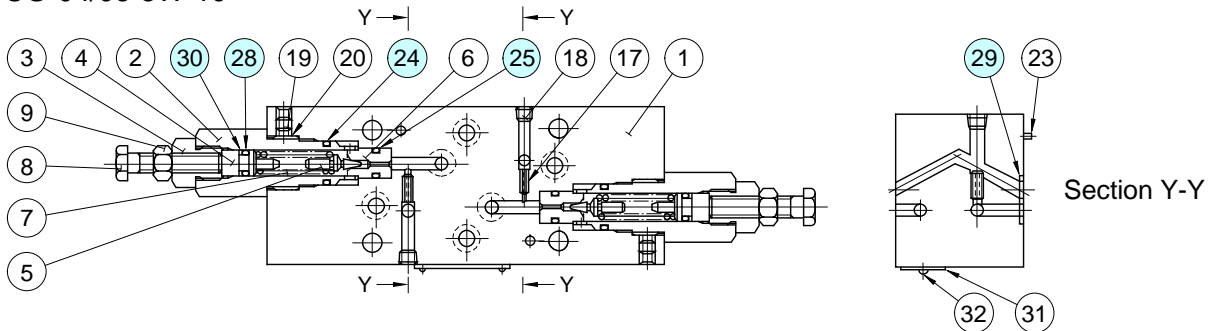

● List of Seals

Item	Name of Parts	CG-04				CG-06					
		Part Numbers	Quantity				Part Numbers	Quantity			
			-4W	-4A	-5W	-5A		-4W	-4A	-5W	-5A
24	O-Ring	SO-NB-P12	2	1	2	1	SO-NB-P16	2	1	2	1
25	O-Ring	SO-NB-P9	2	1	2	1	SO-NB-P11	2	1	2	1
26	O-Ring	SO-NB-P10	3	4	—	—	SO-NB-P10	3	4	—	—
27	O-Ring	SO-NB-P8	2	2	—	—	SO-NB-P8	2	2	—	—
28	O-Ring	SO-NA-P6	2	1	2	1	SO-NA-P9	2	1	2	1
29	O-Ring	SO-NB-P8	8	8	8	8	SO-NB-P9	8	8	8	8
30	Back Up Ring	SO-BB-P6	2	1	2	1	SO-BB-P9	2	1	2	1

Note: When ordering the seals, please specify the seal kit number listed in page 24.



### Spare Parts List

Model Numbers	Pilot Valve Model Numbers	Seal Kit Numbers		
		Complete Kit	For Pilot Selector Valves	For Pilot Valves
DSLHG-04-1-★-▲-12 DSLHG-04-1-★-▲-1290	DSG-01-3C9-★-▲-60 DSG-01-3C9-★-▲-6090	KS-DSLHG-04-1-▲-12	KS-CG-04-1-10	KS-DSG-01-▲-60 (1 Set Req'd)
DSLHG-04-2-★-▲-12 DSLHG-04-2-★-▲-1290	DSG-01-3C9-★-▲-60 DSG-01-3C9-★-▲-6090	KS-DSLHG-04-2-▲-12	KS-CG-04-2-10	
DSLHG-04-3-★-▲-12 DSLHG-04-3-★-▲-1290	DSG-01-2B2-★-▲-60 DSG-01-2B2-★-▲-6090	KS-DSLHG-04-3-▲-12		KS-DSG-01-▲-60 (2 Set Req'd)
DSLHG-04-4A-★-▲-12 DSLHG-04-4A-★-▲-1290	DSG-01-3C9-★-▲-60 DSG-01-3C9-★-▲-6090	KS-DSLHG-04-4A-▲-12	KS-CG-04-4A-10	KS-DSG-01-▲-60 (1 Set Req'd)
DSLHG-04-4W-★-▲-12 DSLHG-04-4W-★-▲-1290	DSG-01-3C9-★-▲-60 DSG-01-3C9-★-▲-6090	KS-DSLHG-04-4W-▲-12	KS-CG-04-4W-10	
DSLHG-04-5A-★-▲-12 DSLHG-04-5A-★-▲-1290	DSG-01-2B2-★-▲-60 DSG-01-2B2-★-▲-6090	KS-DSLHG-04-5A-▲-12	KS-CG-04-5A-10	KS-DSG-01-▲-60 (2 Set Req'd)
DSLHG-04-5W-★-▲-12 DSLHG-04-5W-★-▲-1290	DSG-01-2B2-★-▲-60 DSG-01-2B2-★-▲-6090	KS-DSLHG-04-5W-▲-12	KS-CG-04-5W-10	
DSLHG-06-1-★-▲-12 DSLHG-06-1-★-▲-1290	DSG-01-3C9-★-▲-60 DSG-01-3C9-★-▲-6090	KS-DSLHG-06-1-▲-12	KS-CG-06-1-10	KS-DSG-01-▲-60 (1 Set Req'd)
DSLHG-06-2-★-▲-12 DSLHG-06-2-★-▲-1290	DSG-01-3C9-★-▲-60 DSG-01-3C9-★-▲-6090	KS-DSLHG-06-2-▲-12	KS-CG-06-2-10	
DSLHG-06-3-★-▲-12 DSLHG-06-3-★-▲-1290	DSG-01-2B2-★-▲-60 DSG-01-2B2-★-▲-6090	KS-DSLHG-06-3-▲-12	KS-CG-06-3-10	KS-DSG-01-▲-60 (2 Set Req'd)
DSLHG-06-4A-★-▲-12 DSLHG-06-4A-★-▲-1290	DSG-01-3C9-★-▲-60 DSG-01-3C9-★-▲-6090	KS-DSLHG-06-4A-▲-12	KS-CG-06-4A-10	KS-DSG-01-▲-60 (1 Set Req'd)
DSLHG-06-4W-★-▲-12 DSLHG-06-4W-★-▲-1290	DSG-01-3C9-★-▲-60 DSG-01-3C9-★-▲-6090	KS-DSLHG-06-4W-▲-12	KS-CG-06-4W-10	
DSLHG-06-5A-★-▲-12 DSLHG-06-5A-★-▲-1290	DSG-01-2B2-★-▲-60 DSG-01-2B2-★-▲-6090	KS-DSLHG-06-5A-▲-12	KS-CG-06-5A-10	KS-DSG-01-▲-60 (2 Set Req'd)
DSLHG-06-5W-★-▲-12 DSLHG-06-5W-★-▲-1290	DSG-01-2B2-★-▲-60 DSG-01-2B2-★-▲-6090	KS-DSLHG-06-5W-▲-12	KS-CG-06-5W-10	
DSLHG-10-1-★-▲-12 DSLHG-10-1-★-▲-1290	DSG-01-3C9-★-▲-60 DSG-01-3C9-★-▲-6090	KS-DSLHG-10-1-▲-12	KS-CG-06-1-10	KS-DSG-01-▲-60 (1 Set Req'd)
DSLHG-10-2-★-▲-12 DSLHG-10-2-★-▲-1290	DSG-01-3C9-★-▲-60 DSG-01-3C9-★-▲-6090	KS-DSLHG-10-2-▲-12	KS-CG-06-2-10	
DSLHG-10-3-★-▲-12 DSLHG-10-3-★-▲-1290	DSG-01-2B2-★-▲-60 DSG-01-2B2-★-▲-6090	KS-DSLHG-10-3-▲-12	KS-CG-06-3-10	KS-DSG-01-▲-60 (2 Set Req'd)
DSLHG-10-4A-★-▲-12 DSLHG-10-4A-★-▲-1290	DSG-01-3C9-★-▲-60 DSG-01-3C9-★-▲-6090	KS-DSLHG-10-4A-▲-12	KS-CG-06-4A-10	KS-DSG-01-▲-60 (1 Set Req'd)
DSLHG-10-4W-★-▲-12 DSLHG-10-4W-★-▲-1290	DSG-01-3C9-★-▲-60 DSG-01-3C9-★-▲-6090	KS-DSLHG-10-4W-▲-12	KS-CG-06-4W-10	
DSLHG-10-5A-★-▲-12 DSLHG-10-5A-★-▲-1290	DSG-01-2B2-★-▲-60 DSG-01-2B2-★-▲-6090	KS-DSLHG-10-5A-▲-12	KS-CG-06-5A-10	KS-DSG-01-▲-60 (2 Set Req'd)
DSLHG-10-5W-★-▲-12 DSLHG-10-5W-★-▲-1290	DSG-01-2B2-★-▲-60 DSG-01-2B2-★-▲-6090	KS-DSLHG-10-5W-▲-12	KS-CG-06-5W-10	

Note 1: Fill coil type (a symbol representing current/voltage) in section marked ★. Likewise, in section marked ▲, fill a symbol representing the type of electrical conduit connection (None: Terminal Box Type, N: Plug-in Connector Type).

2: A complete seal kit is composed of seal kit for pilot selector valve, seal kit for pilot valve and seal for main valve. See pages 20 and 21 for information on the seals for main valve.

3: See a catalogue (No. Pub.EC-0402) for the detailed information on the pilot valves.

#### ■ How to Change Pilot & Drain Connection

Pilot Connection and Drain Connection can be changed easily with a disconnection/connection of pilot plug. The following drawings give illustrations of External Pilot-External Drain Type, When changing to Internal Pilot-Internal Drain Type, the following procedure may be followed.

#### ● External Pilot → Internal Pilot (See Section E-E)

- 1) Remove pipe plug ①.
- 2) Remove pipe plug ②.
- 3) Wind a sealing tape around the pipe plug ①, then fit the plug into the port.

#### ● External Drain → Internal Drain (See Section D-D)

- 1) Remove pipe plug ③.
- 2) Remove pipe plug ④.
- 3) Wind a sealing tape around the pipe plug ③, then fit the plug into the port.
- 4) In case of DSLHG-04, fit the plug into the port "Y" on the sub-plate. In case of DSLHG-06/10, wind a sealing tape around the plug ④ and then thread it into the port "Y".

#### DSLHG-04

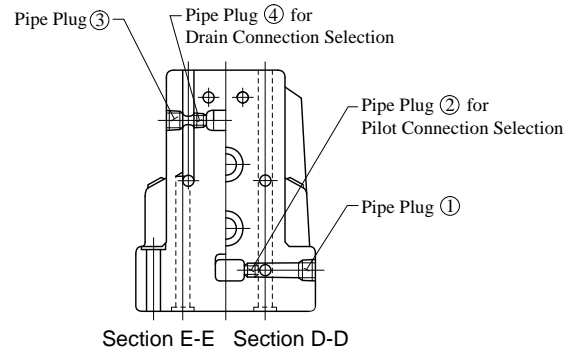
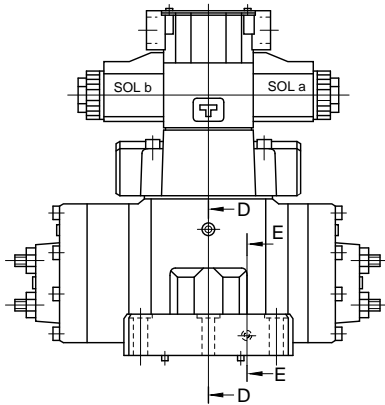

#### DSLHG-06/10

