

RESTRICTORS

SRT/SRG-03/06/10 (3/8, 3/4, 1-1/4)

ONE WAY RESTRICTORS

SRCT/SRCG-03/06/10 (3/8, 3/4, 1-1/4)

Threaded Connections / Sub-plate Mounting

FLOW CONTROLS

Up to 25 MPa (3630 PSI), 500 L/min (132 U.S.GPM)

This valve is used to regulate an actuator speed in a circuit where line pressure is almost steady and small fluctuation of oil flow due to pressure changes is permitted. Integrated check valve allows reversed free flow from outlet to inlet port. Pressure balanced construction provides less effort in adjustment at high pressure.

■ Restrictors

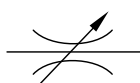
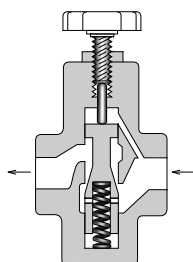

■ One Way Restrictors

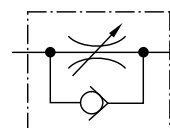
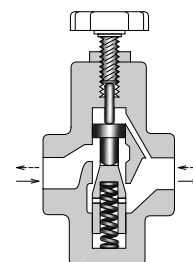

■ Hydraulic Fluids

● Fluid Types

Any type of hydraulic fluid listed in the table below can be used.

Petroleum base oils	Use fluids equivalent to ISO VG 32 or VG 46.
Synthetic fluids	Use phosphate ester or polyol ester fluid. When phosphate ester fluid is used, prefix "F-" to the model number because the special seals (fluororubber) are required to be used.
Water containing fluids	Use water-glycol fluid.

Note: For use with hydraulic fluids other than those listed above, please consult your Yuken representatives in advance.

● Recommended Viscosity and Temperatures

Viscosity ranging between 15 - 400 mm²/s (77 - 1800 SSU).

Oil temperatures between -15/+70°C (5 - 158°F).

Use hydraulic fluids which satisfy the recommended viscosity and oil temperatures given above.

● Control of Contamination

Due caution must be paid to maintaining control over contamination of the hydraulic fluids which may otherwise lead to breakdowns and shorten the life of the valves. Please maintain the degree of contamination within NAS 1638-Grade 12. Use 25 μm or finer line filter.

Specifications

Valve Name	Model Numbers		Rated Flow* L/min (U.S.GPM)	Max. Operating Pres. MPa (PSI)	Approx. Mass kg (lbs.)	
	Threaded Connection	Sub-plate Mounting			Threaded Connection	Sub-plate Mounting
Restrictor	SRT-03-50/5080/5090	SRG-03-50/5090	30 (7.9)	25 (3630)	1.5 (3.3)	2.5 (5.5)
	SRT-06-50/5080/5090	SRG-06-50/5090	85 (22.4)		3.8 (8.4)	3.9 (8.6)
	SRT-10-50/5080/5090	SRG-10-50/5090	230 (60.7)		9.1 (20.1)	7.5 (16.5)
One Way Restrictor	SRCT-03-50/5080/5090	SRCG-03-50/5090	30 (7.9)	25 (3630)	1.5 (3.3)	2.5 (5.5)
	SRCT-06-50/5080/5090	SRCG-06-50/5090	85 (22.4)		3.8 (8.4)	3.9 (8.6)
	SRCT-10-50/5080/5090	SRCG-10-50/5090	230 (60.7)		9.1 (20.1)	7.5 (16.5)

★ Rated flow stands for approximate flow rate when the pressure drop between inlet and outlet ports of the valve in fully opened condition becomes 0.3 MPa (44 PSI) maximum at fluid's specific gravity of 0.85 and kinematic viscosity of 20 mm²/s (98 SSU).

Yuken can offer flanged connection valves described below.

For details, contact us.

Model Numbers	Rated Flow L/min (U.S.GPM)	Max. Operating Pressure MPa (PSI)
SRF/SRCF-10-50 SRF/SRCF-10-5090	230 (60.7)	25 (3630)
SRF/SRCF-16-50 SRF/SRCF-16-5090	500 (132)	

Graphic Symbols

SRT / SRG



SRCT / SRCG

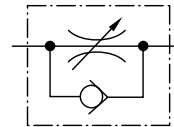

Model Number Designation

F-	SR	T	-03	-50	*
Special Seals	Series Number	Type of Mounting	Valve Size	Design Number	Design Standards
F: Special Seals for Phosphate Ester Type Fluids (Omit if not required)	SR: Restrictor	T: Threaded Connection	03	50	None: Japanese Std. "JIS" 80: European Design Std. 90: N.American Design Std.
			06	50	
			10	50	
		G: Sub-plate Mounting	03	50	
			06	50	
			10	50	
	SRC: One Way Restrictor	T: Threaded Connection	03	50	None: Japanese Std. "JIS" 80: European Design Std. 90: N.American Design Std.
			06	50	
			10	50	
		G: Sub-plate Mounting	03	50	
			06	50	
			10	50	

■ Attachment

● Mounting Bolts

Valve Model Numbers	Socket Head Cap Screw		Qty.
	Japanese Std. "JIS" and European Design Std.	N. American Design Std.	
SRG/SRCG-03	M10 × 45 Lg.	3/8-16 UNC × 1-3/4 Lg.	4
SRG/SRCG-06	M10 × 50 Lg.	3/8-16 UNC × 2 Lg.	4
SRG/SRCG-10	M10 × 55 Lg.	3/8-16 UNC × 2-1/4 Lg.	6

■ Sub-plate

Valve Model Numbers	Japanese Standard "JIS"		European Design Standard		N. American Design Standard		Approx. Mass kg (lbs.)
	Sub-plate Model Numbers	Thread Size	Sub-plate Model Numbers	Thread Size	Sub-plate Model Numbers	Thread Size	
SRG SRCG -03	CRGM-03-50	Rc 3/8	CRGM-03-5080	3/8 BSP.F	CRGM-03-5090	3/8 NPT	1.6 (3.5)
	CRGM-03X-50	Rc 1/2	CRGM-03X-5080	1/2 BSP.F	CRGM-03X-5090	1/2 NPT	1.6 (3.5)
SRG SRCG -06	CRGM-06-50	Rc 3/4	CRGM-06-5080	3/4 BSP.F	CRGM-06-5090	3/4 NPT	2.4 (5.3)
	CRGM-06X-50	Rc 1	CRGM-06X-5080	1 BSP.F	CRGM-06X-5090	1 NPT	3.0 (6.6)
SRG SRCG -10	CRGM-10-50	Rc 1-1/4	CRGM-10-5080	1-1/4 BSP.F	CRGM-10-5090	1-1/4 NPT	4.8 (10.6)
	CRGM-10X-50	Rc 1-1/2	CRGM-10X-5080	1-1/2 BSP.F	CRGM-10X-5090	1-1/2 NPT	5.7 (12.6)

- Sub-plates are available. Specify the sub-plate model number from the table above. When sub-plates are not used, the mounting surface should have a good machined finish.

■ Instructions

● Flow Adjustment

Slacken the lock nut and turn the flow adjustment knob anti-clockwise to throttle flow. After achieving satisfactory performance tighten the lock nut.

SRT/SRCT-03-50/5080/5090
SRT/SRCT-06-50/5080/5090
SRT/SRCT-10-50/5080/5090

DIMENSIONS IN
MILLIMETRES (INCHES)

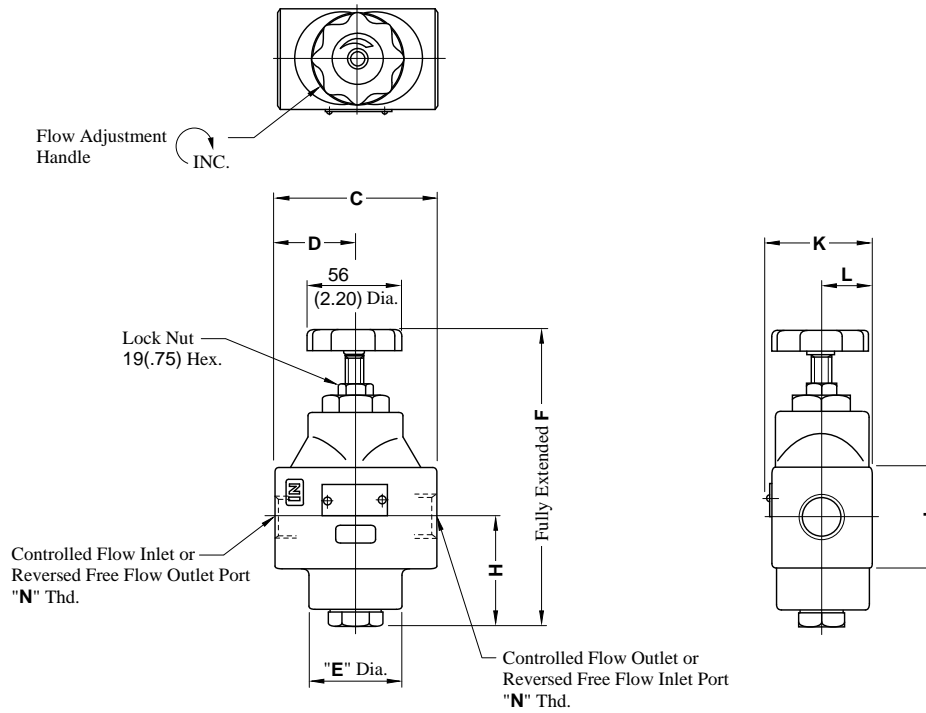

Model Numbers	Dimensions mm (Inches)								Thd. Size
	C	D	E	F	H	J	K	L	"N" Thd.
SRT/SRCT-03-50	72	36	44	150.5	53.5	38	46	22	Rc 3/8
SRT/SRCT-03-5080	(2.83)	(1.42)	(1.73)	(5.93)	(2.11)	38 Dia.	(1.81)	(.87)	3/8 BSP.F
SRT/SRCT-03-5090									3/8 NPT
SRT/SRCT-06-50	100	50	58	180	66.5	62	64	31	Rc 3/4
SRT/SRCT-06-5080	(3.94)	(1.97)	(2.28)	(7.09)	(2.62)	62 Sq.	(2.52)	(1.22)	3/4 BSP.F
SRT/SRCT-06-5090									3/4 NPT
SRT/SRCT-10-50	138	69	80	227	86	80	82	40	Rc 1-1/4
SRT/SRCT-10-5080	(5.43)	(2.72)	(3.15)	(8.94)	(3.39)	80 Sq.	(3.23)	(1.57)	1-1/4 BSP.F
SRT/SRCT-10-5090									1-1/4 NPT

SRG/SRCG-03-50/5090

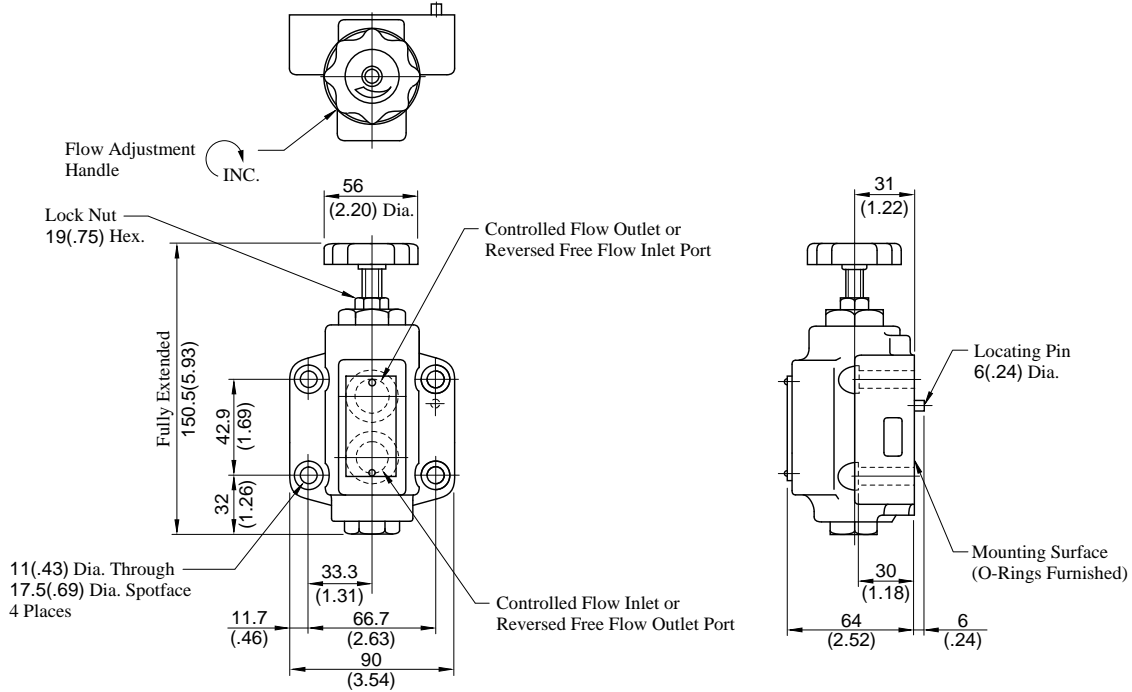

DIMENSIONS IN
MILLIMETRES (INCHES)

■ Sub-plate

CRGM-⁰³_{03X}-50/5080/5090

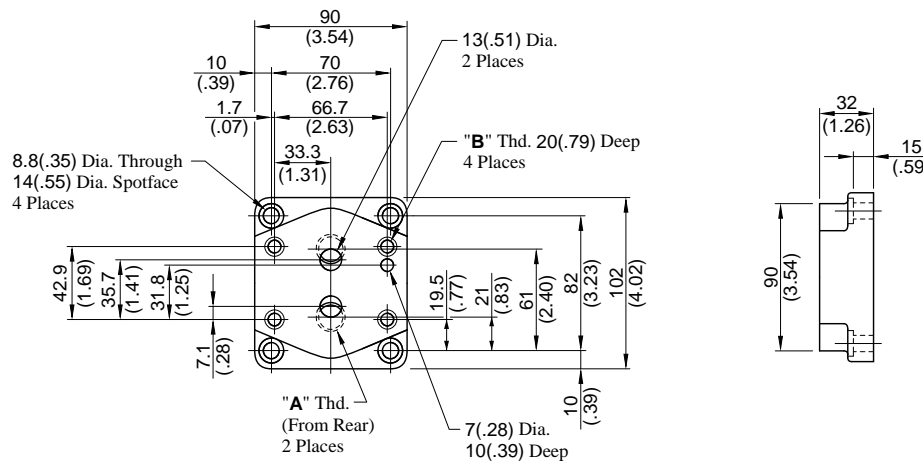

Sub-plate Model Numbers	"A" Thd.	"B" Thd.
CRGM-03-50	Rc 3/8	M10
CRGM-03-5080	3/8 BSP.F	
CRGM-03-5090	3/8 NPT	3/8-16 UNC
CRGM-03X-50	Rc 1/2	M10
CRGM-03X-5080	1/2 BSP.F	
CRGM-03X-5090	1/2 NPT	3/8-16 UNC

SRG/SRCG-06-50/5090

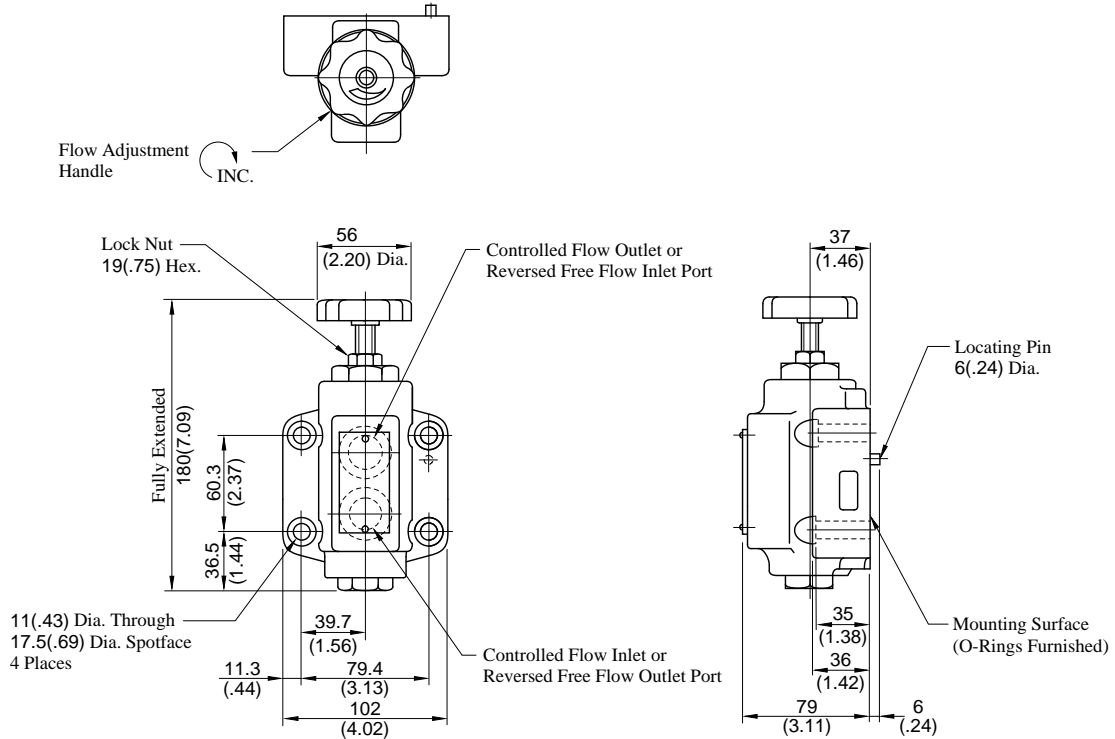

**DIMENSIONS IN
MILLIMETRES (INCHES)**

Sub-plate

CRGM-06 06X-50/5080/5090

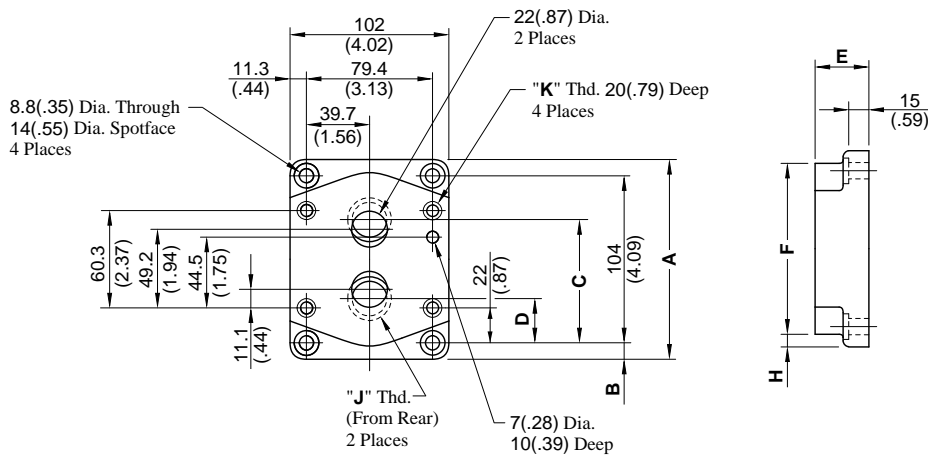

Sub-plate Model Numbers	Dimensions mm (Inches)							"J" Thd.	"K" Thd.
	A	B	C	D	E	F	H		
CRGM-06-50	124 (4.88)	10 (.39)	77 (3.03)	27 (1.06)	36 (1.42)	110 (4.33)	7 (.28)	Rc 3/4	M10
CRGM-06-5080								3/4 BSP.F	
CRGM-06-5090								3/4 NPT	
CRGM-06X-50	136 (5.35)	16 (.63)	82.3 (3.24)	22 (.87)	45 (1.77)	136 (5.35)	0	Rc 1	M10
CRGM-06X-5080			80 (3.15)	24 (.94)				1 BSP.F	
CRGM-06X-5090			82.3 (3.24)	22 (.87)				1 NPT	

SRG/SRCG-10-50/5090

Mounting surface: ISO 5781-AJ-10-2-A

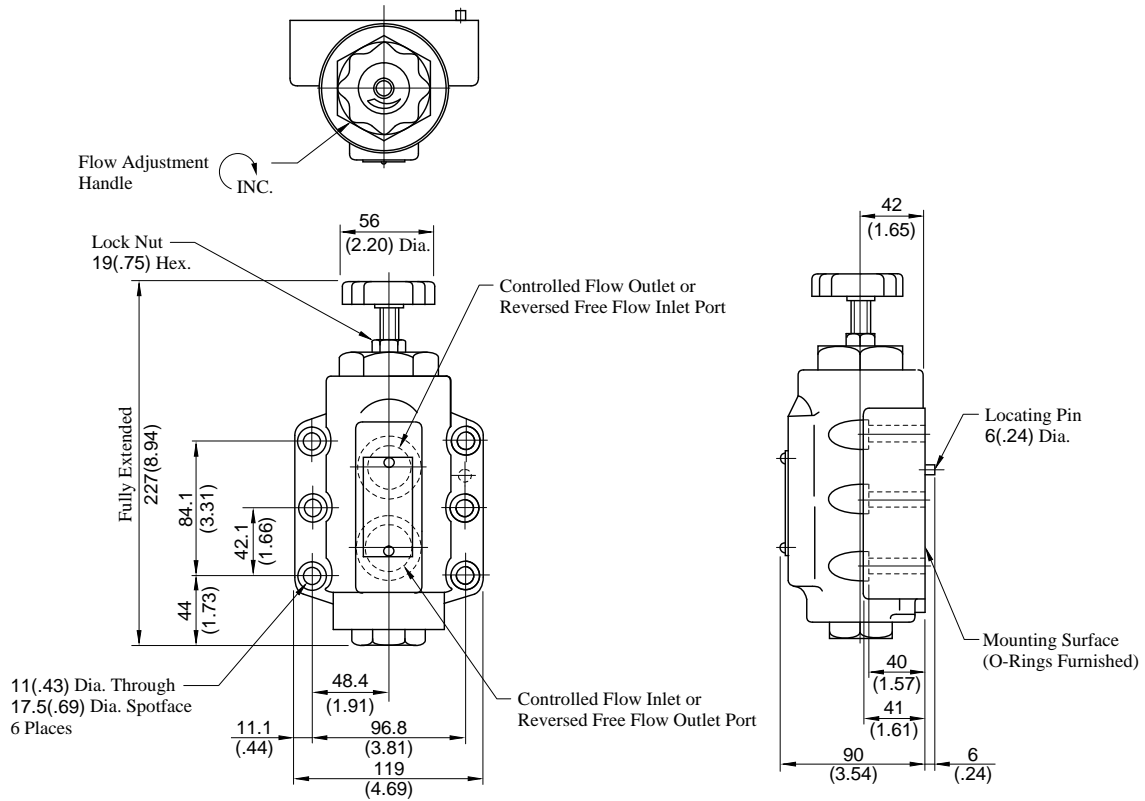

DIMENSIONS IN MILLIMETRES (INCHES)

Sub-plate

CRGM-10-50/5080/5090

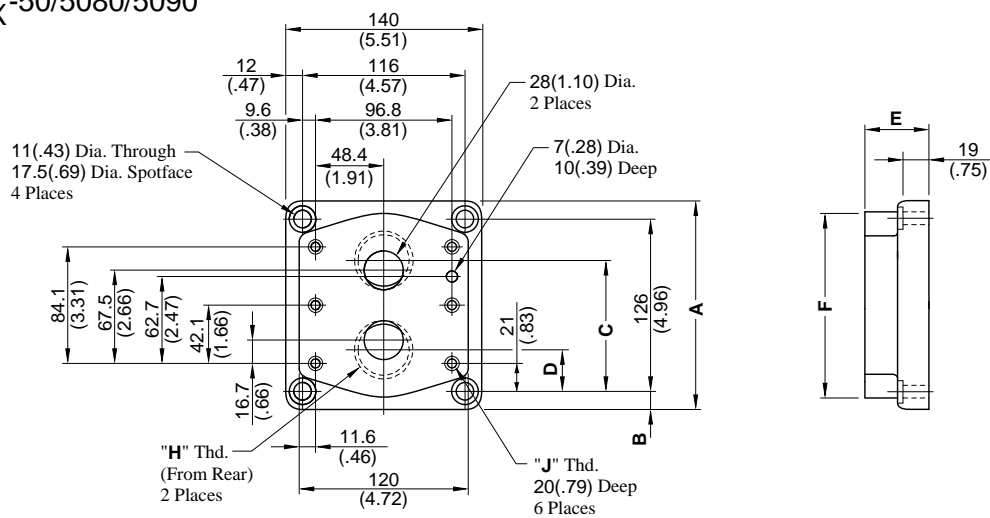

Sub-plate Model Numbers	Dimensions mm (Inches)						"H" Thd.	"J" Thd.
	A	B	C	D	E	F		
CRGM-10-50							Rc 1-1/4	M10
CRGM-10-5080	150 (5.91)	12 (.47)	96 (3.78)	30 (1.18)	45 (1.77)	135 (5.31)	1-1/4 BSP.F	
CRGM-10-5090							1-1/4 NPT	
CRGM-10X-50							Rc 1-1/2	M10
CRGM-10X-5080	177 (6.97)	25.5 (1.00)	104 (4.09)	22 (.87)	50 (1.97)	167 (6.57)	1-1/2 BSP.F	
CRGM-10X-5090							1-1/2 NPT	

Hydraulic Fluid: Viscosity 30 mm²/s (141 SSU), Specific Gravity 0.850

Metred Flow vs Adjustment Handle Revolutions

ΔP: Differential Pressure MPa (PSI)

● SRT SRG-03, SRCT SRCG-03

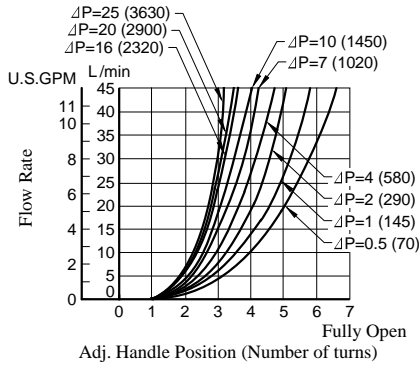

● SRT SRG-06, SRCT SRCG-06

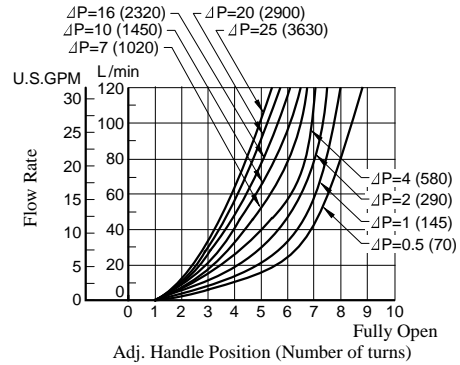

● SRT SRG-10, SRCT SRCG-10

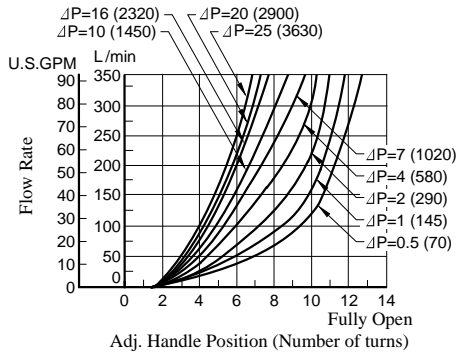

Pressure Drop

● SRT SRG-03, SRCT SRCG-03

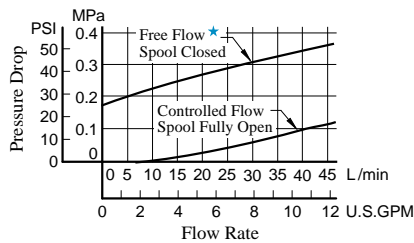

● SRT SRG-06, SRCT SRCG-06

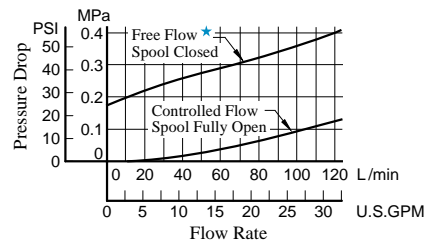

● SRT SRG-10, SRCT SRCG-10

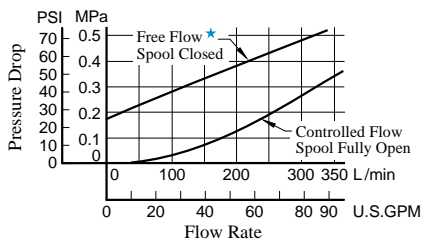

★ Applicable only for one way restrictor (Model No. SRC*)

Spare Parts List

SRT/SRCT-03-50/5080/5090
SRT/SRCT-06-50/5080/5090
SRT/SRCT-10-50/5080/5090

⚠ CAUTION

When making replacement of seals, please do it carefully after reading through the relevant instructions in the Operator's Manual.

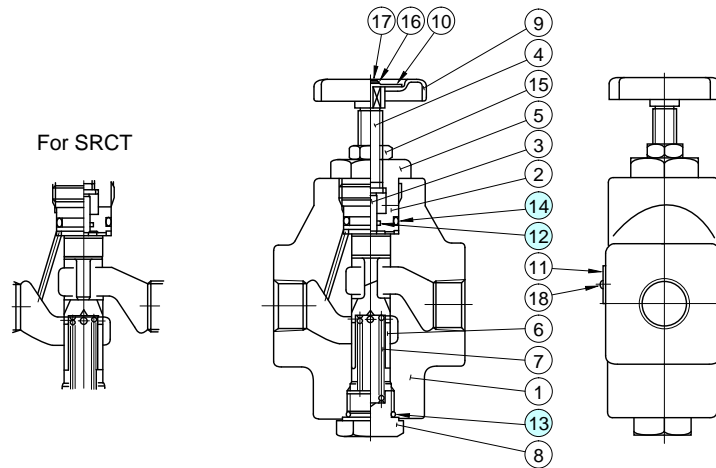

● List of Seals

Item	Name of Parts	Part Numbers			Qty.
		SRT SRCT-03	SRT SRCT-06	SRT SRCT-10	
12	O-Ring	SO-NB-P7	SO-NB-P7	SO-NB-P7	1
13	O-Ring	SO-NB-P15	SO-NB-P21	SO-NB-P29	1
14	O-Ring	SO-NB-P20	SO-NB-P22.4	SO-NB-P36	1

Note: When ordering the seals, please specify the seal kit number from the table right.

● List of Seal Kits

Model Numbers	Seal Kit Numbers
SRT/SRCT-03	KS-SRT-03-50
SRT/SRCT-06	KS-SRT-06-50
SRT/SRCT-10	KS-SRT-10-50

SRG/SRCG-03-50/5090
SRG/SRCG-06-50/5090
SRG/SRCG-10-50/5090

For SRCG

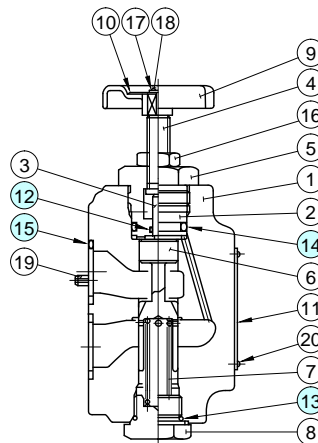
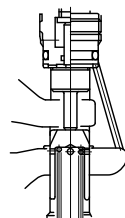

● List of Seals

Item	Name of Parts	Part Numbers			Qty.
		SRG SRCG-03	SRG SRCG-06	SRG SRCG-10	
12	O-Ring	SO-NB-P7	SO-NB-P7	SO-NB-P7	1
13	O-Ring	SO-NB-P15	SO-NB-P21	SO-NB-P29	1
14	O-Ring	SO-NB-P20	SO-NB-P22.4	SO-NB-P36	1
15	O-Ring	SO-NB-P18	SO-NB-P28	SO-NB-P32	2

Note: When ordering the seals, please specify the seal kit number from the table right.

● List of Seal Kits

Model Numbers	Seal Kit Numbers
SRG/SRCG-03	KS-SRG-03-50
SRG/SRCG-06	KS-SRG-06-50
SRG/SRCG-10	KS-SRG-10-50