

Specifications

Model Numbers	Max. Operating Pressure MPa (PSI)	Pres. Adj. Range MPa (PSI)	Max. Flow L/min (U.S.GPM)	Approx. Mass kg (lbs.)
S-BG-03-*-*-40*	25 (3630)	Note)	100 (26.4)	4.1 (9.0)
S-BG-06-*-*-40*		★-25	200 (52.8)	5.0 (11.0)
S-BG-10-*-*-40*		(★-3630)	400 (106)	10.5 (23.1)

Note: See minimum adjustment pressure characteristics on page 18.

Model Number Designation

F-	S-	B	G	-03	-V	-L	-40	*
Special Seals	Low Noise Type	Series Number	Type of Mounting	Valve Size	High Venting* ¹ Pres. Feature	Direction of Handle	Design Number	Design Std.
F: Special Seals for Phosphate Ester Type Fluids (Omit if not required)	S: Low Noise Type	B: Pilot Operated Relief Valves	G: Sub-plate Mounting	03	V: For High Venting Pressure Feature (Omit if not required)	(Viewed from pressure gauge connection) L: Left (Normal) R: Right	40	Refer to ★ ²
				06			40	
				10			40	

★¹. Use the high venting pressure type where it is necessary to reduce the response time from unloading to onloading.

★². Design Standards: None Japanese Standard "JIS" and European Design Standard 90 N. American Design Standard

Sub-plate

Valve Model Numbers	Japanese Standard "JIS"		European Design Standard		N. American Design Standard		Approx. Mass kg (lbs.)
	Sub-plate Model Numbers	Thread Size	Sub-plate Model Numbers	Thread Size	Sub-plate Model Numbers	Thread Size	
S-BG-03	BGM-03-20	Rc 3/8	BGM-03-3080	3/8 BSP.F	BGM-03-2090	3/8 NPT	2.4 (5.3)
	BGM-03X-20	Rc 1/2	BGM-03X-3080	1/2 BSP.F	BGM-03X-2090	1/2 NPT	3.1 (6.8)
S-BG-06	BGM-06-20	Rc 3/4	BGM-06-3080	3/4 BSP.F	BGM-06-2090	3/4 NPT	4.7 (10.4)
	BGM-06X-20	Rc 1	BGM-06X-3080	1 BSP.F	BGM-06X-2090	1 NPT	5.7 (12.6)
S-BG-10	BGM-10-20	Rc 1-1/4	BGM-10-3080	1-1/4 BSP.F	BGM-10-2090	1-1/4 NPT	8.4 (18.5)
	BGM-10X-20	Rc 1-1/2	BGM-10X-3080	1-1/2 BSP.F	BGM-10X-2090	1-1/2 NPT	10.3 (22.7)

• Sub-plates are available. Specify the sub-plate model number from the table above. When sub-plates are not used, the mounting surface should have a good machined finish.

• The sub-plates are those for pilot operated relief valves. For dimensions, see page 13.

Attachment

Mounting Bolts

Valve Model Numbers	Socket Head Cap Screw		Qty.
	Japanese Std. "JIS" and European Design Std.	N. American Design Std.	
S-BG-03	M12 × 40 Lg.	1/2-13 UNC × 1-1/2 Lg.	4
S-BG-06	M16 × 50 Lg.	5/8-11 UNC × 2 Lg.	4
S-BG-10	M20 × 60 Lg.	3/4-10 UNC × 2-1/4 Lg.	4

Instructions

- If a remote control relief valve is used in the vent circuit, see page 3. In addition, if the internal volume of the vent line is too large, chattering is likely to occur. Thus, as far as possible reduce the inside Dia. and the length of the pipe.
- Pressure is limited by collars fitted. If a working pressure cannot be attained, remove some collars. One collar is equivalent to 10 MPa (1450 PSI).
- With a small flow, the setting pressure may be unstable. Use models numbered 03 and 06 with a flow rate above 5 L/min (1.3 U.S. GPM) and model 10 with 8 L/min (2.1 U.S. GPM).

S-BG-03-**-L-40/4090
S-BG-06-**-L-40/4090
S-BG-10-**-L-40/4090

Mounting surface
S-BG-03: ISO 6264-AR-06-2-A
S-BG-06: ISO 6264-AS-08-2-A
S-BG-10: ISO 6264-AT-10-2-A

DIMENSIONS IN
MILLIMETRES (INCHES)

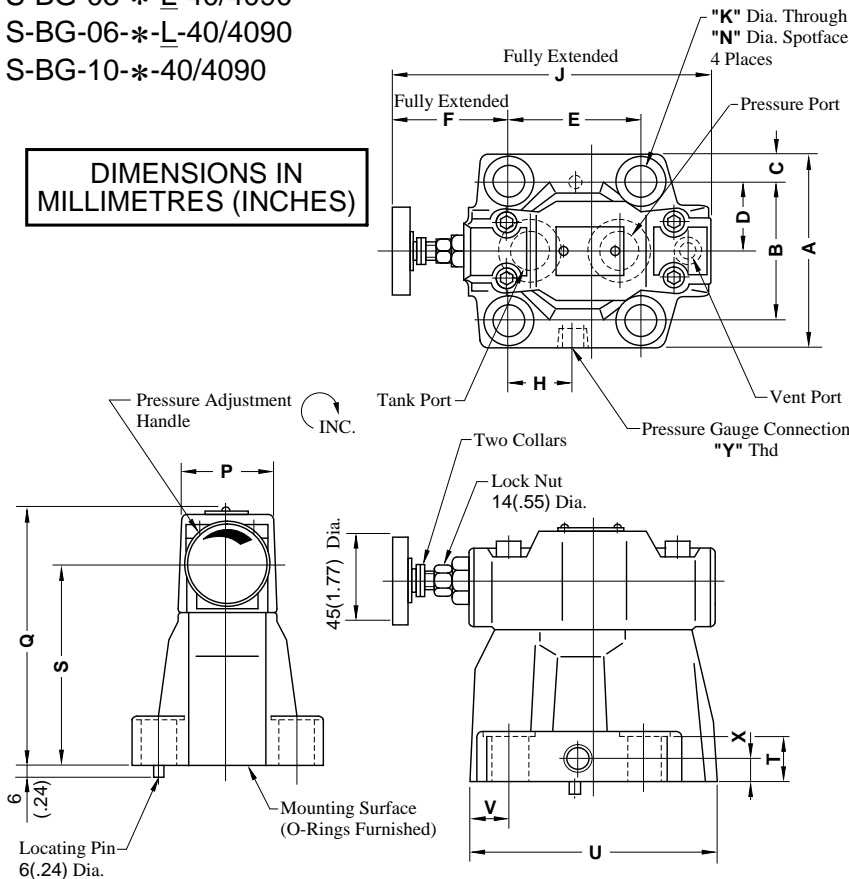

Opposite Handle Position

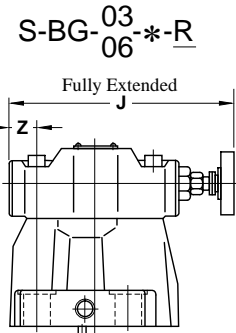

Note: For other dimensions, see the figures shown left.

Note: For dimensions of the valve mounting surface, see the dimensional drawing (P. 13) of the sub-plate used together.

Model Numbers	"Y" Thd.
S-BG-03-**-40	Rc 1/4 = 1/4 BSP.Tr
S-BG-03-**-4090	1/4 NPT
S-BG-06-**-40	Rc 1/4 = 1/4 BSP.Tr
S-BG-06-**-4090	1/4 NPT
S-BG-10-**-40	Rc 1/4 = 1/4 BSP.Tr
S-BG-10-**-4090	1/4 NPT

Model Numbers	Dimensions mm (Inches)																	
	A	B	C	D	E	F	H	J	K	N	P	Q	S	T	U	V	X	Z
S-BG-03	76 (2.99)	53.8 (2.12)	11.1 (.44)	26.9 (1.06)	53.8 (2.12)	73.6 (2.90)	26.9 (1.06)	163.5 (6.44)	13.5 (.53)	21 (.83)	50 (1.97)	130 (5.12)	103 (4.06)	21.5 (.85)	106 (4.17)	26.1 (1.03)	13 (.51)	36.1 (1.42)
S-BG-06	98 (3.86)	70 (2.76)	14 (.55)	35 (1.38)	66.7 (2.63)	58.8 (2.31)	33.7 (1.33)	163.5 (6.44)	17.5 (.69)	26 (1.02)	50 (1.97)	130 (5.12)	103 (4.06)	26 (1.02)	122 (4.80)	19.3 (.76)	13 (.51)	21.3 (.84)
S-BG-10	120 (4.72)	82.6 (3.25)	18.7 (.74)	41.3 (1.63)	88.9 (3.50)	50.6 (1.99)	44.9 (1.77)	180 (7.09)	21.5 (.85)	32 (1.26)	65 (2.56)	167 (6.57)	135 (5.31)	33.5 (1.32)	155 (6.10)	21.2 (.83)	18 (.71)	—

Performance Characteristics

Nominal Override Characteristics

Hydraulic fluid:
Viscosity : 35 mm²/s (164 SSU)
Specific Gravity : 0.850

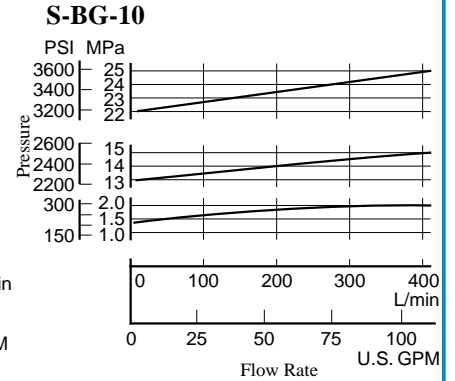
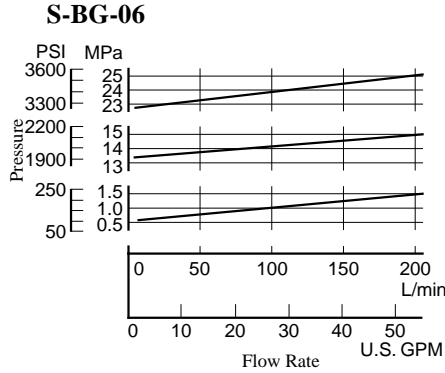
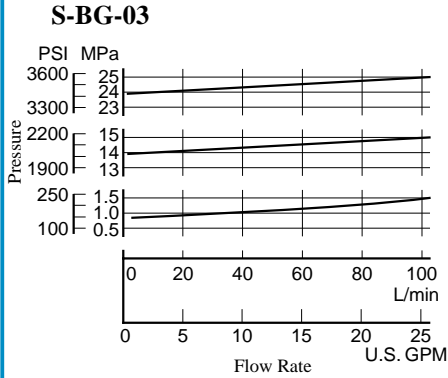

Min. Adj. Pressure and Vent Pressure vs. Flow

Hydraulic fluid:
Viscosity : 35 mm²/s (164 SSU)
Specific Gravity : 0.850

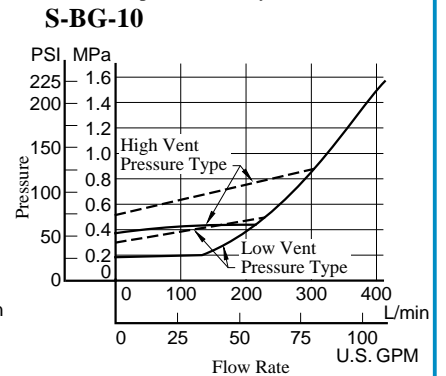
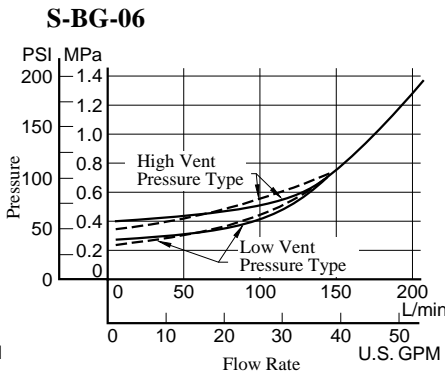
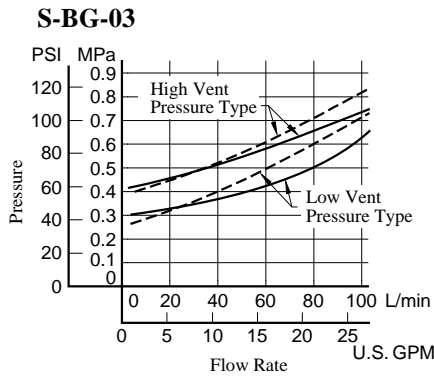

Noise Level

Measuring condition
Measuring position: At 1m (3.3 ft.) back from the valve front.

Viscosity : 35 mm²/s (164 SSU)
Back pressure : 0.1 MPa (14.5 PSI)

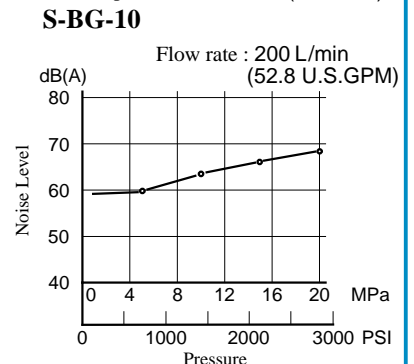
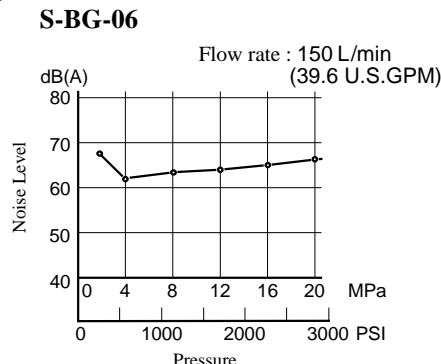
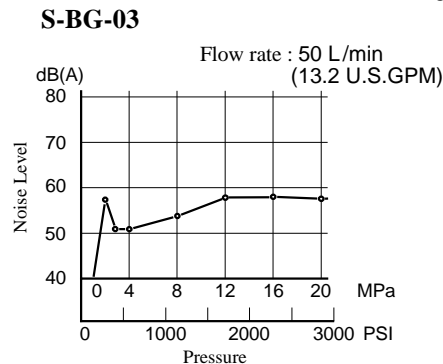

Spare Parts List

S-BG-03,06,10-*40/4090

CAUTION

When making replacement of seals, please do it carefully after reading through the relevant instructions in the Operator's Manual.

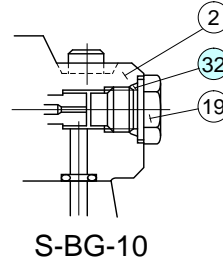
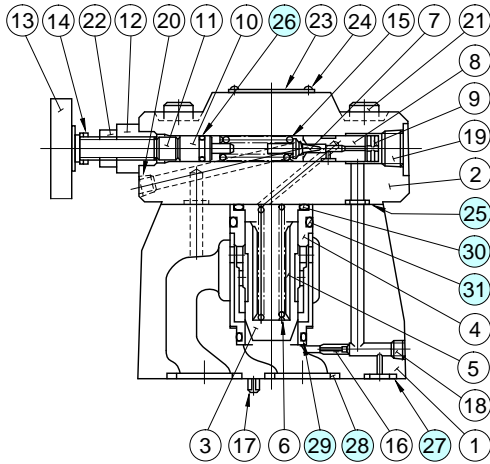

List of Seals

Item	Name of Parts	Part Numbers			Qty.
		S-BG-03	S-BG-06	S-BG-10	
25	O-Ring	SO-NB-P9	SO-NB-P9	SO-NB-P9	2
26	O-Ring	SO-NA-P9	SO-NA-P9	SO-NA-P9	1
27	O-Ring	SO-NB-P9	SO-NB-P11	SO-NB-P9	1
28	O-Ring	SO-NB-P18	SO-NB-P28	SO-NB-P32	2
29	O-Ring	SO-NB-A024	SO-NB-A024	SO-NB-A128	1
30	O-Ring	SO-NB-P28	SO-NB-P28	SO-NB-P36	1
31	O-Ring	SO-NB-P32	SO-NB-P32	SO-NB-P42	1
32	O-Ring	—	—	SO-NB-P14	1

List of Seal Kits

Model Numbers	Seal Kit Numbers
S-BG-03	KS-S-BG-03-40
S-BG-06	KS-S-BG-06-40
S-BG-10	KS-S-BG-10-40

Note: When ordering the seals, please specify the seal kit number from the table below.

Interchangeability in Installation between Conventional Type and Low-noise Type

The design 40 of low-noise S-BG-03, -06, and -10 is interchangeable for installation with design 32 of conventional BG-03, -06 and -10. Their exterior shapes such as the position of the pressure adjustment handles are different.

DIMENSIONS IN
MILLIMETRES (INCHES)

Conventional Type: BG-06, Design 32
03
10

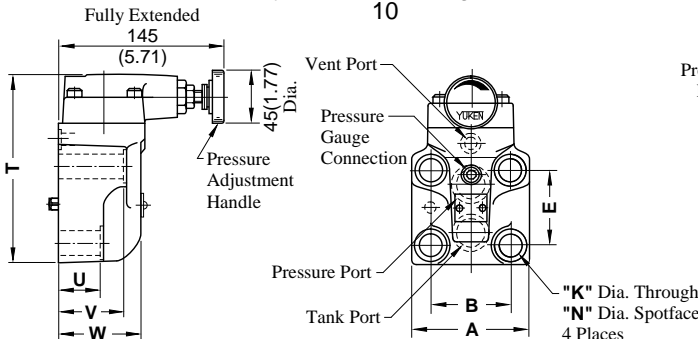

Low-noise type: S-BG-06, Design 40
03
10

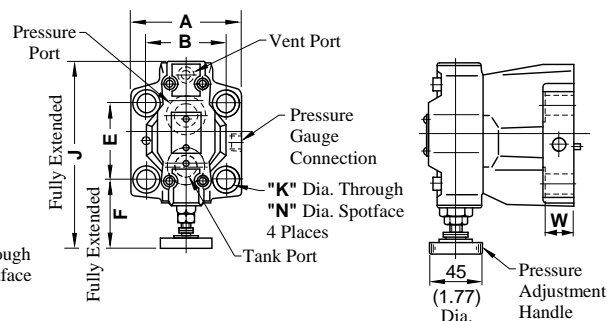

Model Numbers	A	B	E	K	N	T	U	V
BG-03	82 (3.23)	53.8 (2.12)	53.8 (2.12)	13.5 (.53)	21 (.83)	117 (4.61)	55 (2.16)	78 (3.07)
BG-06	104 (4.09)	70 (2.76)	66.7 (2.63)	17.5 (.69)	26 (1.02)	141 (5.55)	38 (1.50)	58 (2.28)
BG-10	124 (4.88)	82.6 (3.25)	88.9 (3.50)	21.5 (.85)	32 (1.26)	175 (6.89)	45 (1.77)	65 (2.56)

Model Numbers	A	B	E	F	K	N	J	W
S-BG-03	76 (2.99)	53.8 (2.12)	53.8 (2.12)	73.6 (2.90)	13.5 (.53)	21 (.83)	163.5 (6.44)	20.5 (.81)
S-BG-06	98 (3.86)	70 (2.76)	66.7 (2.63)	58.8 (2.31)	17.5 (.69)	26 (1.02)	163.5 (6.44)	25 (.98)
S-BG-10	120 (4.72)	82.6 (3.25)	88.9 (3.50)	50.6 (1.99)	21.5 (.85)	32 (1.26)	180 (7.09)	32.5 (1.28)