

Up to 21 MPa (3050 PSI), 237 cm³/rev (14.46 CU.IN./rev)

B

■ Single Pumps

These pumps are of high pressure and high performance, which have been developed especially for low noise operation. To comply with a variety of applications including injection moulding machines, PV2R series single pumps provide the output flow of such a wide range as from 5.8 to 237 cm³/rev (.354 to 14.46 cu.in./rev). The integral driving parts of the pumps are combined into a kit form and available for supply as a cartridge kit. Therefore, the replacement of the driving parts can be done easily.

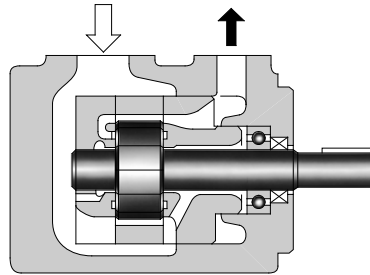
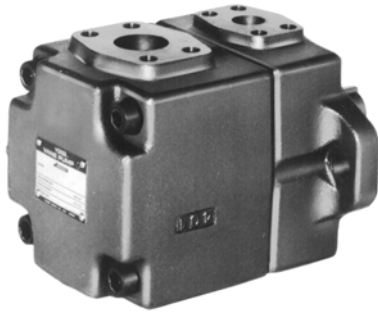

Graphic Symbol

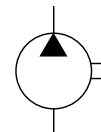

■ Double Pumps

These double pumps consist of two PV2R series single pumps combined in tandem within a single housing and driven by a common shaft. A single suction port and two discharge ports are provided so that the output flow can be supplied to separate circuits.

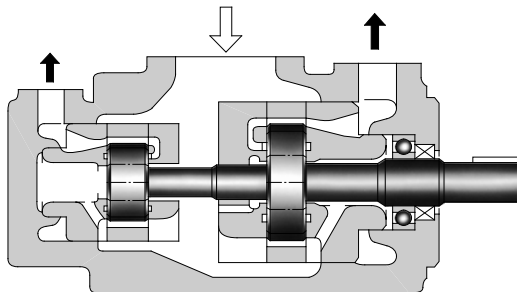
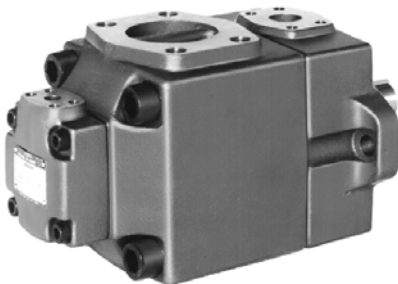

Graphic Symbol

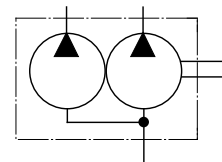

■ Hydraulic Fluids

1. Type of hydraulic fluids

Any type of hydraulic fluids listed in the Table 1 below can be used. However, the specifications of the pumps such as maximum pressure and maximum pump speed may be changed according to the type of hydraulic fluids to be used. For details, please refer to the specifications of the pump concerned.

● Hydraulic fluids

(Table 1)

Type of Fluids		"PV2R" Series Single Pumps "PV2R" Series Double Pumps
Petroleum Base Oils		Use anti-wear type oils or R & O (Rust and Oxidation inhibitor) type oils (equivalent to ISO VG32 or 46).
Synthetic Fluids		Use phosphate ester type fluids. When phosphate ester type fluid is used, prefix "F-" to the model number because the special seals (fluororubber) are required to be used.
Water Containing Fluids	Water-Glycols	Standard pumps can be used without conditions. However, if any type other than those in Table 2 is used, the maximum operating pressure is limited.
	Water in Oil Emulsions	Standard pumps can be used without conditions.

● Anti-wear type water-glycols

(Table 2)

Fluid Manufacturer	Commercial Trade Name
Mobile	Mobil Hydrofluid HFC 46 Mobil Nybac FR 200 D
JAPAN ENERGY CORP.	JOMO Hydria
NIPPON OIL CO., LTD	HYRAND FRX 46
Showa Shell Sekiyu K. K.	Irus Fluid C G-W Fluid 46
MATSUMURA OIL RESEARCH CORP.	HYDOL HAW
COSMO OIL CO., LTD.	COSMO FLUID HQ 46 COSMO FLUID GS 46

2. Fluid viscosity and temperature

Use the hydraulic fluids which satisfy the recommended viscosity and oil temperature given in the Table 3 below. However, please note that if any of the pumps listed in the table 4 is started at low speed, the maximum fluid viscosity is limited.

● Fluid viscosity and temperature

(Table 3)

Fluid	Temperature °C (°F)	Viscosity mm ² /s(SSU)
Petroleum Base Oils	0-70 (32-158)	20-400 (100-1800)
Phosphate Esters		
Water Glycols	0-50 (32-122)	
Water in Oil Emulsions	5-50 (41-122)	

● Maximum viscosity for low start-up speed

(Table 4)

Pump Type	Start-up Speed r/min	Max. Viscosity mm ² /s (SSU)
PV2R1 PV2R12 PV2R13 PV2R14	750	100 (455)
PV2R2 PV2R23 PV2R24	950	200 (910)
	600	100 (455)
	950	200 (910)

3. Control of contamination

Contamination of hydraulic fluids results in pump failures and reduced pump lives. Carry out sufficient contamination control for hydraulic fluids and keep contamination level within NAS class 12. Also, use a 100 μm (150-mesh) tank filter on the suction side, more than 50 mm (2 in.) away from the tank bottom.

■ Instructions

1. Alignment of shaft

Employ a flexible coupling whenever possible, and avoid any stress from bending or thrust. Maximum permissible misalignment is less than 0.1 mm (.004 inches) TIR and maximum permissible misangular is less than 0.2°.

2. Suction pressures

Set the suction pressure at pump inlet port at the value given in the table below. Furthermore, use the pipes in the suction side having the diameter as indicated on the installation drawings. In case where the pump is installed on the tank or at the position higher than the tank top cover, the height of the suction port of the pump should be less than 1 metre (3.3 ft.) from the oil level {less than 0.8 metre (2.6 ft.) in case of using phosphate ester fluids or water containing fluids}.

Pump Type		Suction Pressure		
		Minimum		Maximum
		Petroleum base oil	Phosphate ester type fluid Water containing fluid	
Single Pumps	PV2R1 PV2R2	-20 kPa (5.9 in. Hg Vacuum)	-16 kPa (4.7 in. Hg Vacuum)	+30 kPa (+4.3 PSIG)
	PV2R3 PV2R4	-20 kPa* (5.9 in. Hg Vacuum)*		
Double Pumps	PV2R12	-20 kPa (5.9 in. Hg Vacuum)		
	PV2R13 PV2R23 PV2R33 PV2R14 PV2R24 PV2R34	-20 kPa* (5.9 in. Hg Vacuum)*		

★In relation to the rotating speed of the pump, the minimum suction pressure may be restricted for a certain nominal displacement. For details, please refer to the specifications of the pump concerned.

3. Precautions at starting

At an initial operation or at an operation after a long rest, the pump may have difficulty in sucking up fluid. In such cases, an air bleed valve should be installed beforehand on the discharge side (model No. ST1004-* -10*, Catalogue No. Pub. EC-3001.), or discharge air by slightly slackening the connection on the discharge side. At starting, operate the pump intermittently as far as possible with no load. For fluid viscosity at starting, see the item of "Hydraulic Fluids".

4. Other precautions

If a pump is used at speed below 1200 r/min, install the pump with the suction port upside so that the pump can suck up fluid easily at starting.

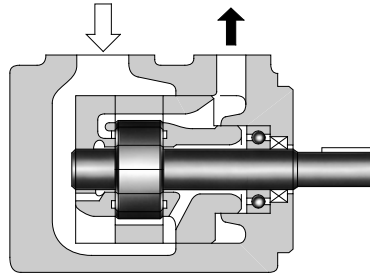
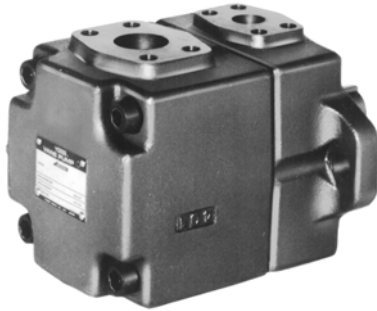

Graphic Symbol

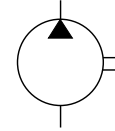

Model Number Designation

F-	PV2R1	-6	-L	-R	A	A	-40	-*
Special Seals	Series Number	Nominal Displacement cm ³ /rev	Type of Mounting	Shaft Rotation	Discharge Port Position	Suction Port Position	Design Number	Design Standards
F: For phosphate ester type fluids (Omit if not required)	PV2R1	6, 8 10, 12 14, 17 19, 23 25, 31	L: Foot Mounting	(Viewed from Shaft End) R: Clockwise ★1 (Normal)	A: Upwards (Normal)	A: Upwards (Normal)	40	Refer to ★2
	PV2R2	41, 47 53, 59 65	F: Flange Mounting				40	
	PV2R3	76, 94 116					30	
	PV2R4	136, 153 184, 200 237					30	

★1. Available to supply pump with anti-clockwise rotation. Consult Yuken for details.
 ★2. Design Standards: None.....Japanese Standard "JIS"
 80.....European Design Standard
 90.....N. American Design Standard

Pipe Flange Kits

Pipe flange kits are available. When ordering, specify the kit number from the table below.

Pump Model Numbers	Name of Port	Pipe Flange Kit Numbers						
		Threaded Connection			Socket Welding*		Butt Welding	
		Japanese Standard "JIS"	European Design Standard	N. American Design Standard	Japanese Standard "JIS" European Design Standard	N. American Design Standard	Japanese Standard "JIS" European Design Standard	N. American Design Standard
PV2R1	Suction	F5-08-A-10	F5-08-A-1080	F5-08-A-1090	F5-08-B-10	F5-08-B-1090	F5-08-C-10	F5-08-C-1090
	Discharge	F5-04-A-10	F5-04-A-1080	F5-04-A-1090	F5-04-B-10	F5-04-B-1090	F5-04-C-10	F5-04-C-1090
PV2R2	Suction	F5-10-A-10	F5-10-A-1080	F5-10-A-1090	F5-10-B-10	F5-10-B-1090	F5-10-C-10	F5-10-C-1090
	Discharge	F5-06-A-10	F5-06-A-1080	F5-06-A-1090	F5-06-B-10	F5-06-B-1090	F5-06-C-10	F5-06-C-1090
PV2R3	Suction	F5-16-A-10	F5-16-A-1080	F5-16-A-1090	F5-16-B-10	F5-16-B-1090	F5-16-C-10	F5-16-C-1090
	Discharge	F5-10-A-10	F5-10-A-1080	F5-10-A-1090	F5-10-B-10	F5-10-B-1090	F5-10-C-10	F5-10-C-1090
PV2R4	Suction	F5-24-A-10	—	—	F5-24-B-10	F5-24-B-1090	F5-24-C-10	F5-24-C-1090
	Discharge	F5-12-A-10	F5-12-A-1080	F5-12-A-1090	F5-12-B-10	F5-12-B-1090	F5-12-C-10	F5-12-C-1090

★In case of using socket welding flanges, there is a case where the operating pressure should be set lower than the normal because of strength of the flanges. Therefore, please pay cautious attention to the operating pressure when the socket welding flanges are used.

Notes: Special seals (Viton seals) are required when phosphate ester type fluids are used. (Prefix "F-" to the pipe flange kit number when ordering.)

●Details of the pipe flange kits are given in the Catalogue No. Pub. EC-3001.

Specifications

Model Numbers	Geometric Displacement cm ³ /rev (cu.in./rev)	Max. Operating Pressure MPa (PSI)						Output Flow & Input Power	Shaft Speed Range r/min	
		Petroleum Base Oils		Water Containing Fluids			Synthetic Fluids		Max.	Min.
		Anti-Wear Type	R & O Type	Anti-Wear ^{★1} Type Water Glycols	Water Glycols	Water in Oil Emulsions	Phosphate Esters			
PV2R1-6	5.8 (.354)	21 ^{★6} (3050)	16 (2320)	16 (2320)	7 (1020)	7 (1020)	16 (2320)	Refer to Pages 11-13	1800 (1200) ^{★4}	750 ^{★5}
PV2R1-8	8.0 (.488)									
PV2R1-10	9.4 (.574)									
PV2R1-12	12.2 (.744)									
PV2R1-14	13.7 (.836)									
PV2R1-17	16.6 (1.013)									
PV2R1-19	18.6 (1.135)									
PV2R1-23	22.7 (1.385)									
PV2R1-25	25.3 (1.544)									
PV2R1-31	31.0 (1.892)	16 (2320)								
PV2R2-41	41.3 (2.52)	21 (3050)	14 (2030)	16 (2320)	7 (1020)	7 (1020)	14 (2030)	Refer to Pages 13&14	1800 (1200) ^{★4}	600 ^{★5}
PV2R2-47	47.2 (2.88)									
PV2R2-53	52.5 (3.20)									
PV2R2-59	58.2 (3.55)									
PV2R2-65	64.7 (3.95)									
PV2R3-76	76.4 (4.66)	21 (3050)	14 (2030)	16 (2320)	7 (1020)	7 (1020)	14 (2030)	Refer to Page 15	1800 (1200) ^{★4}	600
PV2R3-94	93.6 (5.71)								1800 ^{★2} (1200) ^{★4}	
PV2R3-116	115.6 (7.05)	16 (2320)								
PV2R4-136	136 (8.30)	17.5 (2540)	14 (2030)	16 (2320)	7 (1020)	7 (1020)	14 (2030)	Refer to Pages 15&16	1800 (1200) ^{★4}	600
PV2R4-153	153 (9.34)									
PV2R4-184	184 (11.23)									
PV2R4-200	201 (12.26)									
PV2R4-237	237 (14.46)								1800 ^{★3} (1200) ^{★4}	

- ★ 1. For the brands of anti-wear water-glycols , see the item of "Hydraulic Fluids" on page 3.
- ★ 2. If PV2R3-116 is used at speed above 1700 r/min, the suction pressure is limited to 0 kPa (0 in. Hg.).
- ★ 3. If PV2R4-237 is used at speed above 1700 r/min, the suction pressure is limited to -13 kPa (3.94 in. Hg. vacuum).
- ★ 4. If phosphate ester or water containing fluids are used, the maximum speed is limited to 1200 r/min.
- ★ 5. For starting at low speed, the maximum viscosity is limited. For details, see the item of "Hydraulic Fluids" on page 3.
- ★ 6. For pressure above 16 MPa (2320 PSI), raise the speed over 1450 r/min.

● Mass

Model Numbers	Approx. Mass kg (lbs.)	
	Flange Mtg.	Foot Mtg.
PVR2R1	9.0 (19.8)	11.2 (24.7)
PVR2R2	15.5 (34.2)	19.8 (43.7)
PVR2R3	30.9 (68.1)	40.9 (90.2)
PVR2R4	68.5 (151)	93.5 (206)

Flange Mtg.: PV2R1-*-F-RAA-40/4090

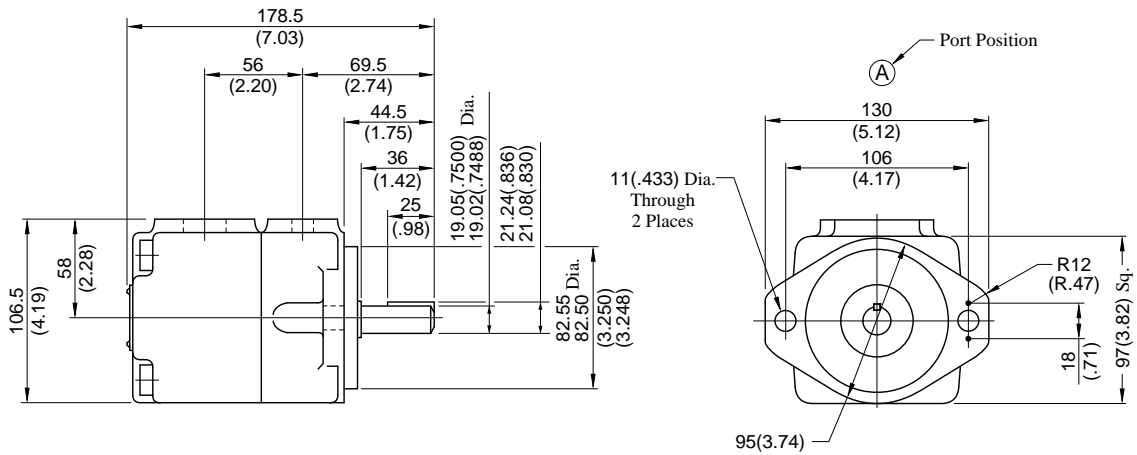
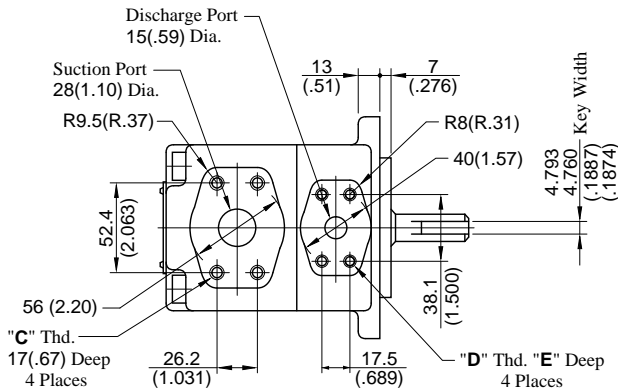

Model Numbers	"C" Thd.	"D" Thd.	E mm (Inches)
PV2R1-*-F-RAA-40	M10	M8	14 (.55)
PV2R1-*-F-RAA-4090	3/8-16 UNC	5/16-18 UNC	16 (.63)

DIMENSIONS IN MILLIMETRES (INCHES)

Foot Mtg.: PV2R1-*-L-RAA-40/4090

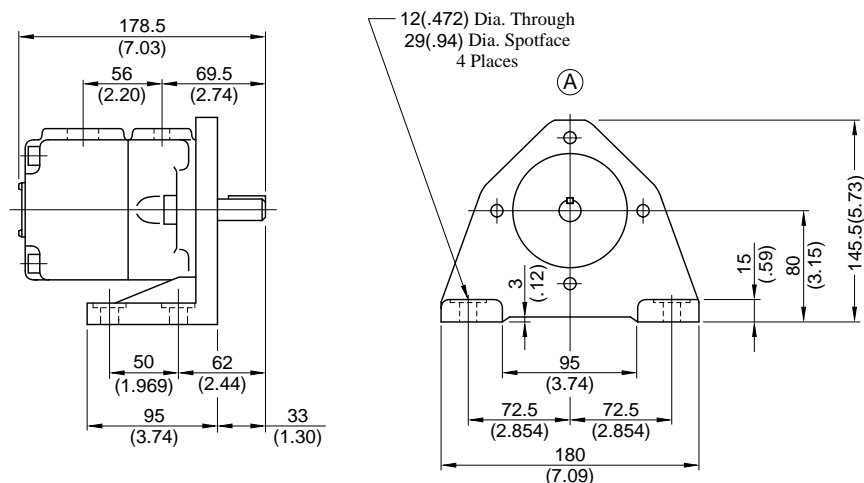

• For other dimensions, refer to "Flange Mtg.".

Flange Mtg.: PV2R2-*-F-RAA-40/4090

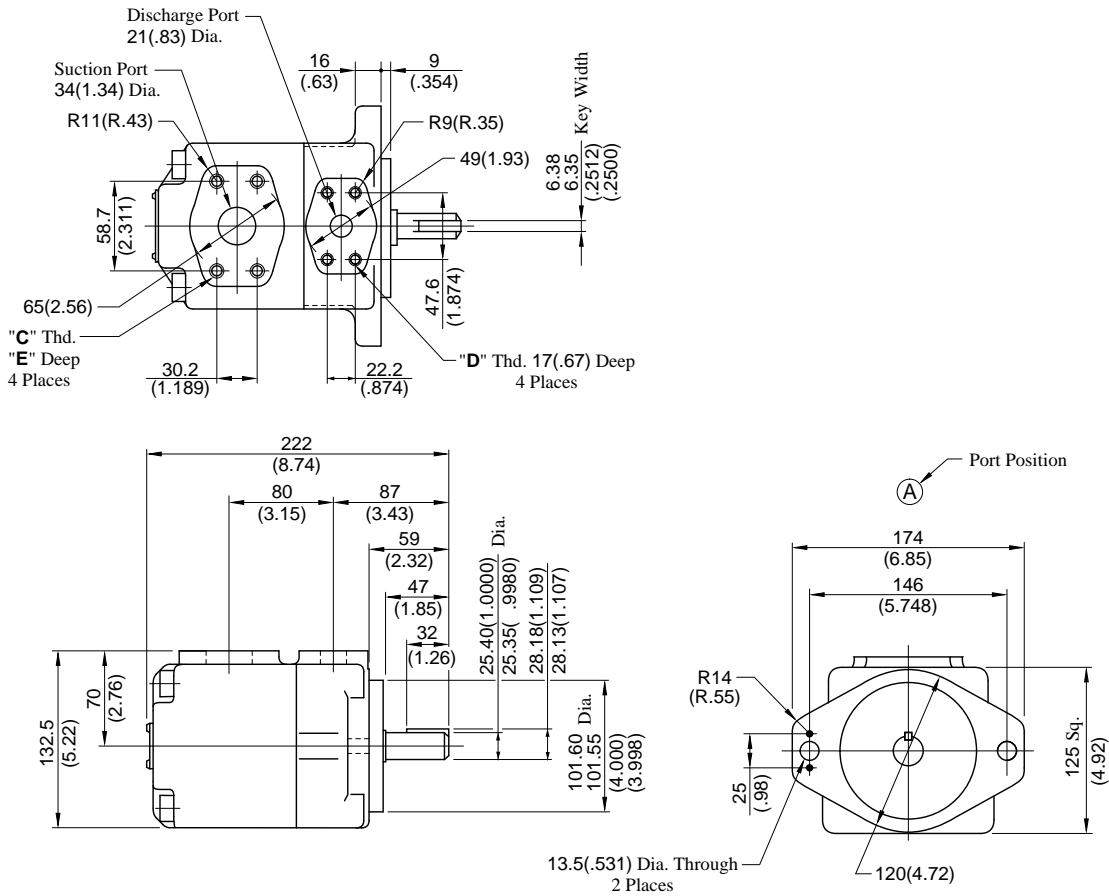

Model Numbers	"C" Thd.	"D" Thd.	E mm (Inches)
PV2R2-*-F-RAA-40	M10	M8	19 (.75)
PV2R2-*-F-RAA-4090	7/16-14 UNC	3/8-16 UNC	20 (.79)

**DIMENSIONS IN
MILLIMETRES (INCHES)**

Foot Mtg.: PV2R2-*-L-RAA-40/4090

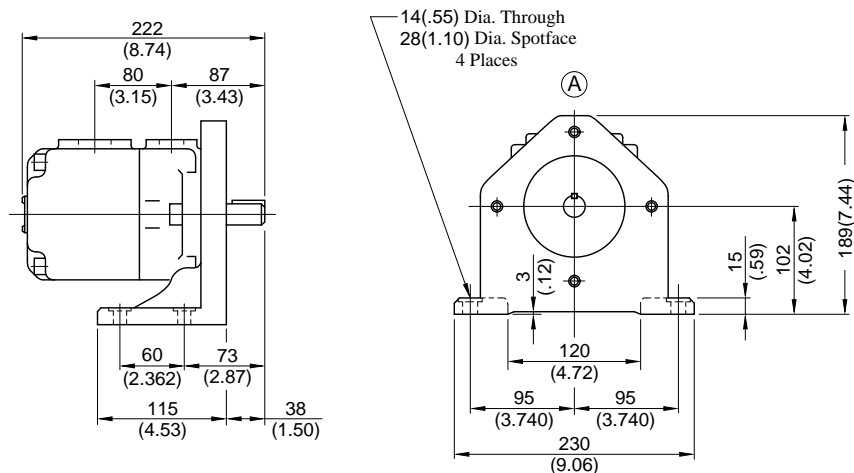

• For other dimensions, refer to "Flange Mtg.".

Flange Mtg.: PV2R3-*-F-RAA-30/3090

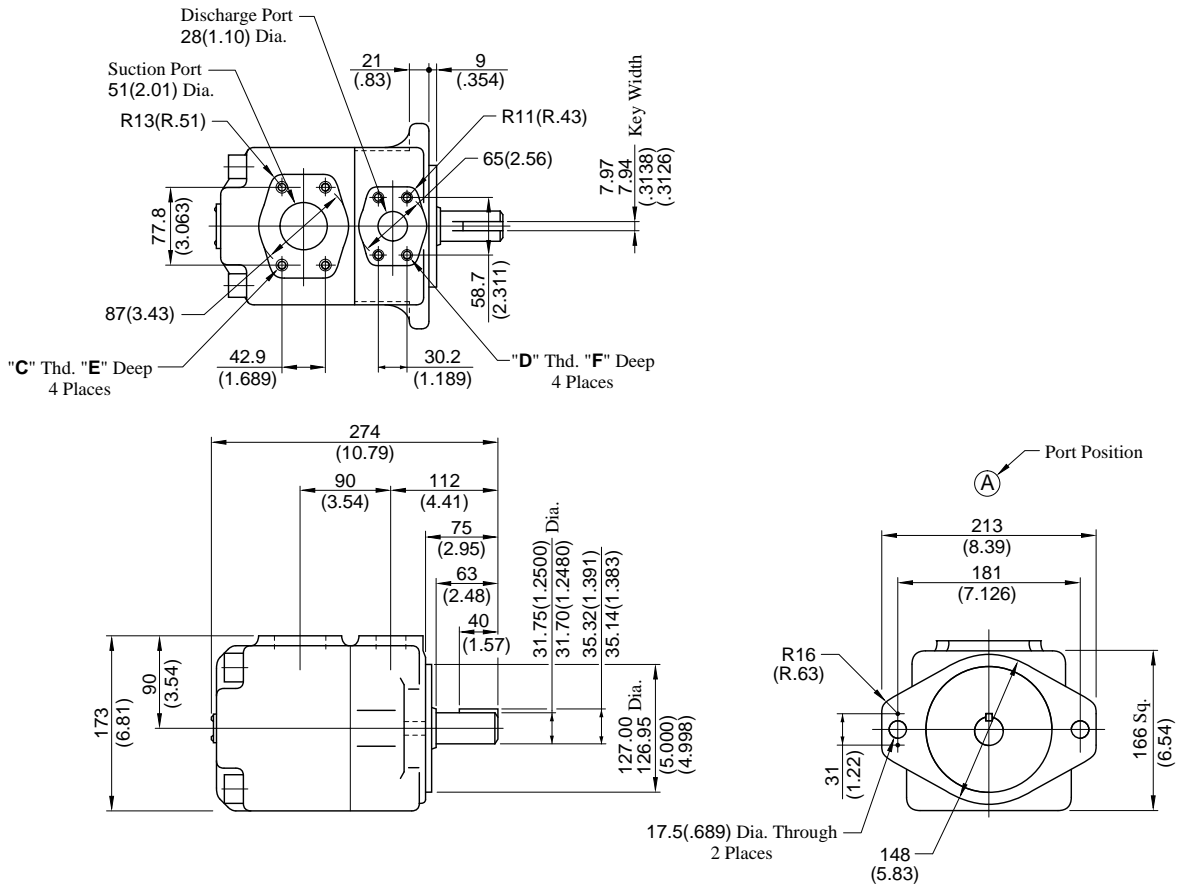

Model Numbers	"C" Thd.	"D" Thd.	Dimensions mm (Inches)	
			E	F
PV2R3-*-F-RAA-30	M12	M10	19 (.75)	19 (.75)
PV2R3-*-F-RAA-3090	1/2-13 UNC	7/16-14 UNC	21 (.83)	20 (.79)

**DIMENSIONS IN
MILLIMETRES (INCHES)**

Foot Mtg.: PV2R3-*-L-RAA-30/3090

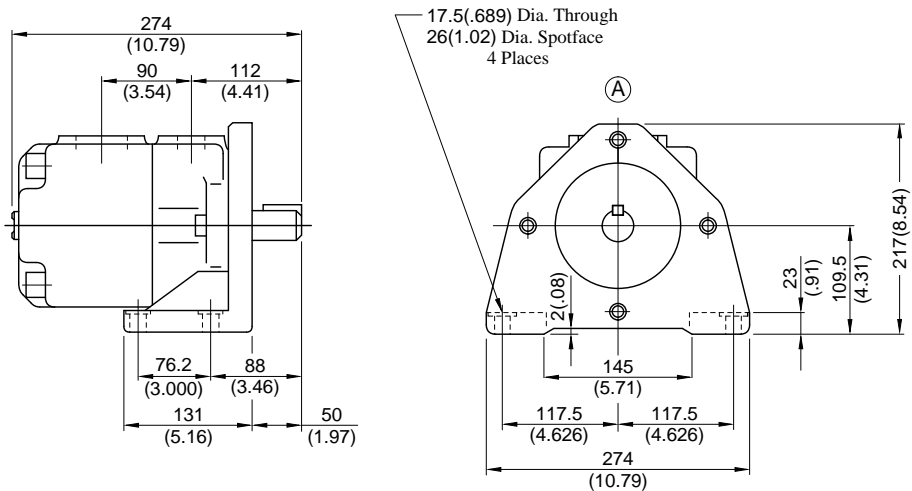

• For other dimensions, refer to "Flange Mtg.".

Flange Mtg.: PV2R4-*-F-RAA-30/3090

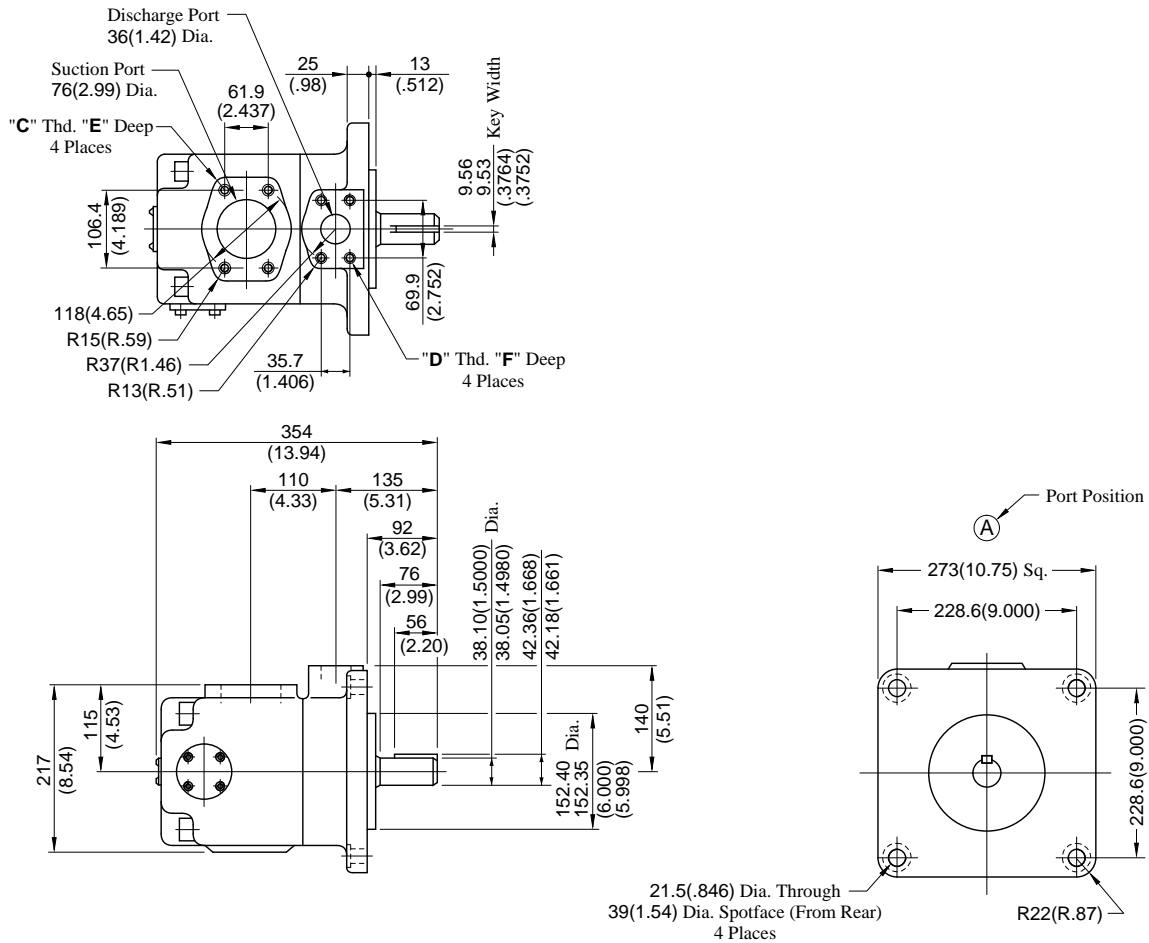

Model Numbers	"C" Thd.	"D" Thd.	Dimensions mm (Inches)	
			E	F
PV2R4-*-F-RAA-30	M16	M12	19 (.75)	19 (.75)
PV2R4-*-F-RAA-3090	1/2-13 UNC	5/8-11 UNC	21 (.83)	21 (.83)

**DIMENSIONS IN
MILLIMETRES (INCHES)**

Foot Mtg.: PV2R4-*-L-RAA-30/3090

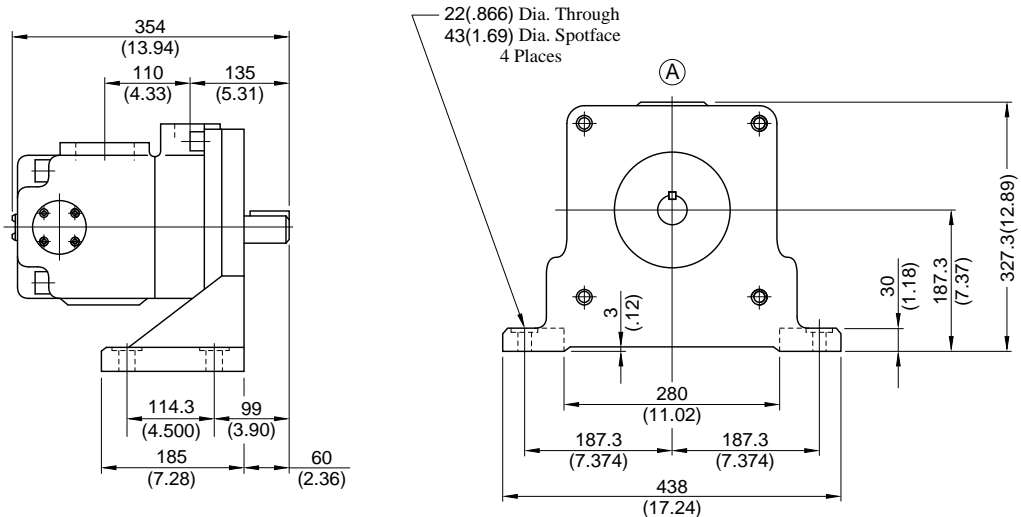

• For other dimensions, refer to "Flange Mtg.".

■ Noise Level

● Measuring conditions

Fluid viscosity : 20 mm²/s (100 SSU)

Measurement point : One metre (3.3 ft.) horizontally away from pump head cover

Back ground noise : 40 dB (A)

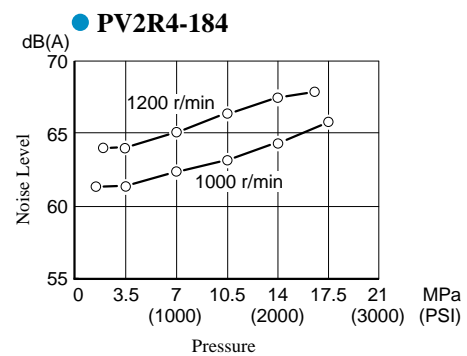
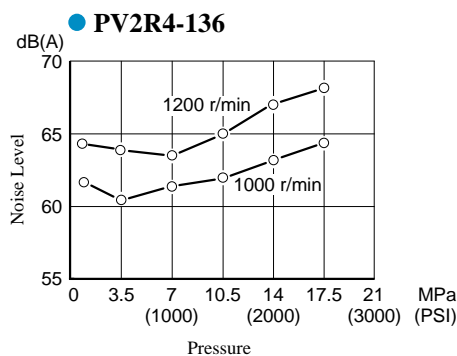
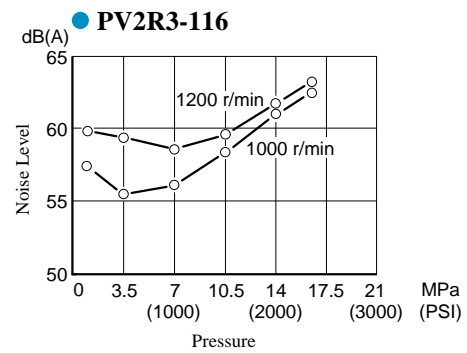
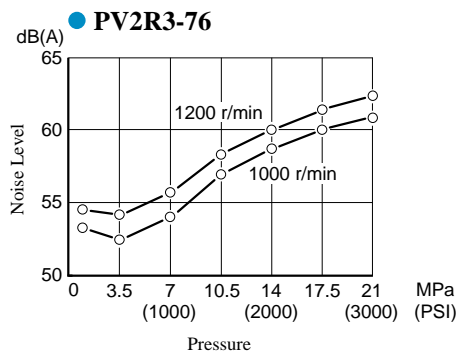
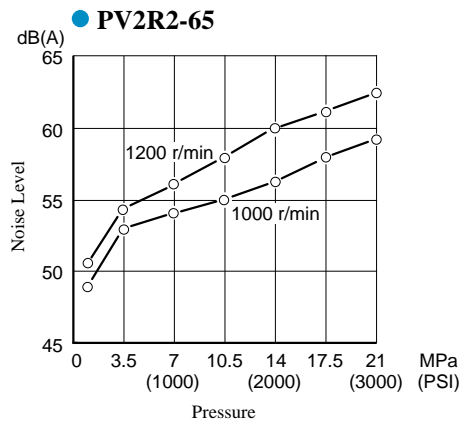
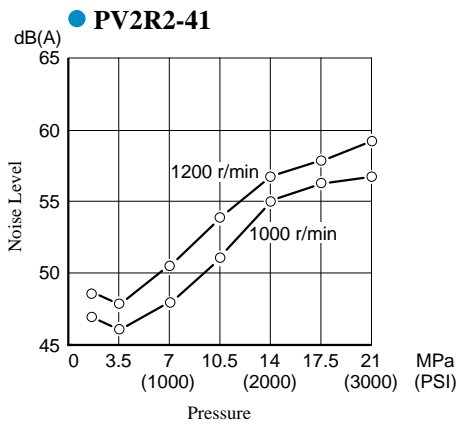
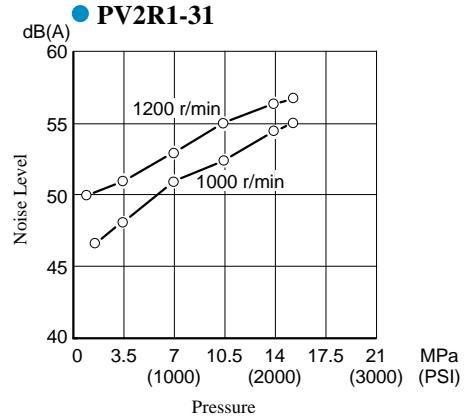
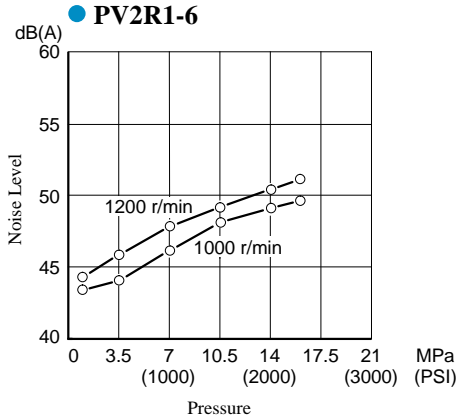

Viscosity 20 mm²/s (100 SSU) [ISO VG32 Oils, 50°C (122°F)]

● PV2R1-6

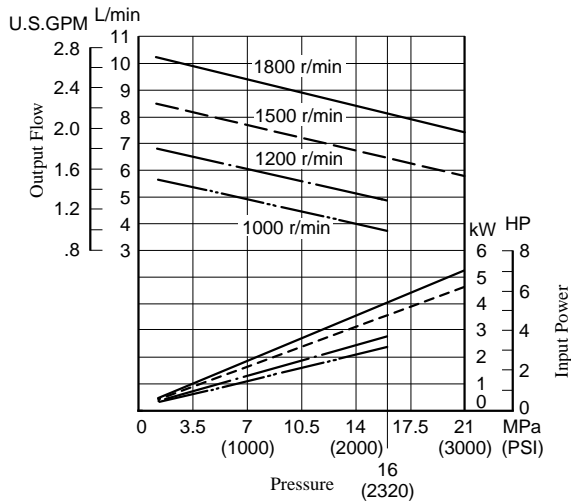

● PV2R1-8

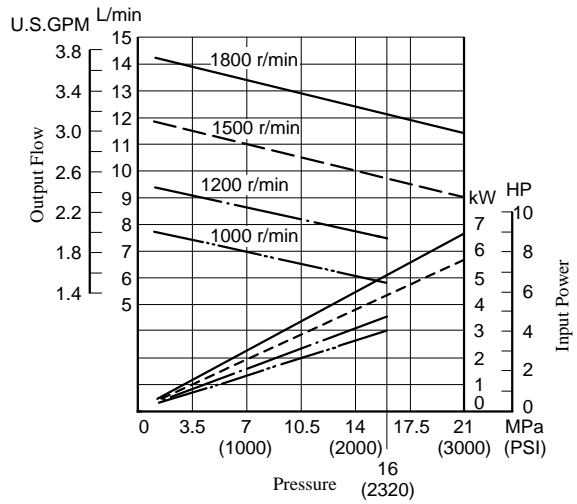

● PV2R1-10

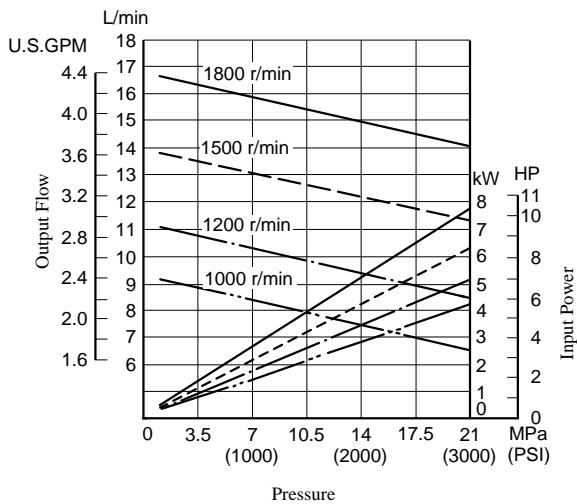

● PV2R1-12

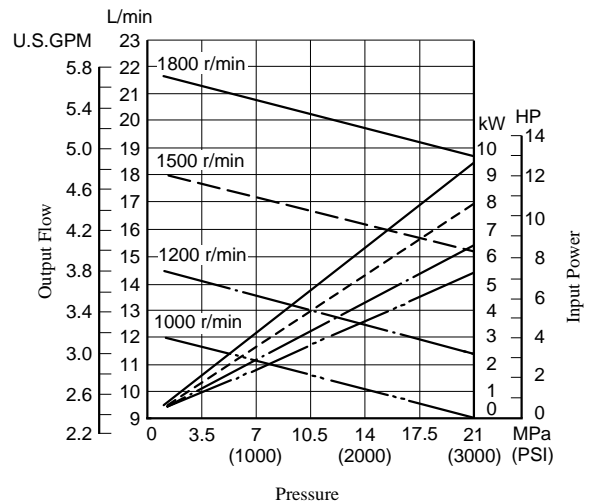

Viscosity 20 mm²/s (100 SSU) [ISO VG32 Oils, 50°C (122°F)]

● PV2R1-14

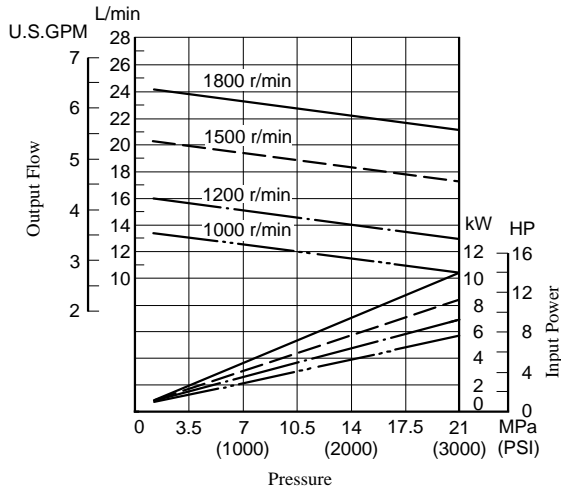

● PV2R1-17

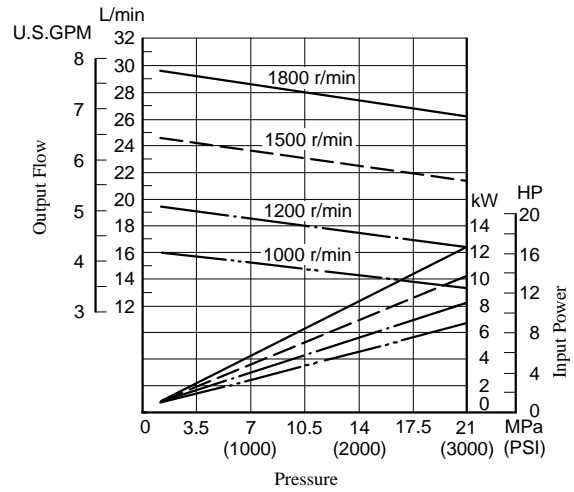

● PV2R1-19

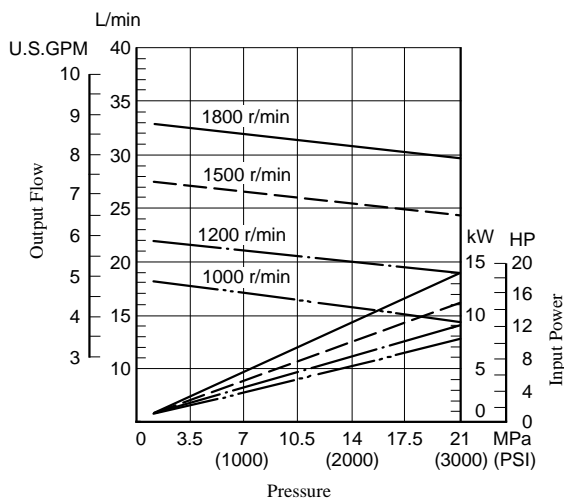

● PV2R1-23

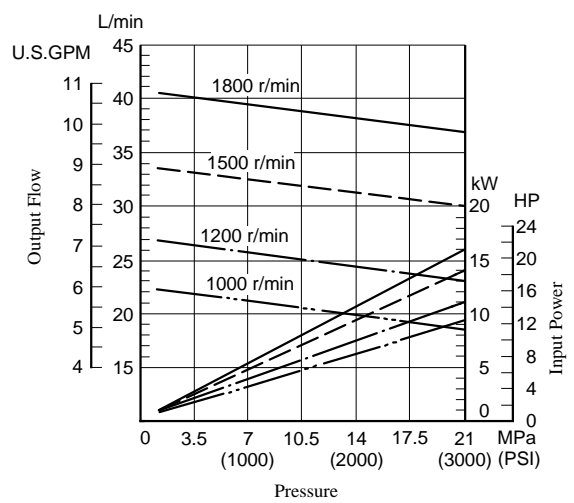

Viscosity 20 mm²/s (100 SSU) [ISO VG32 Oils, 50°C (122°F)]

● PV2R1-25

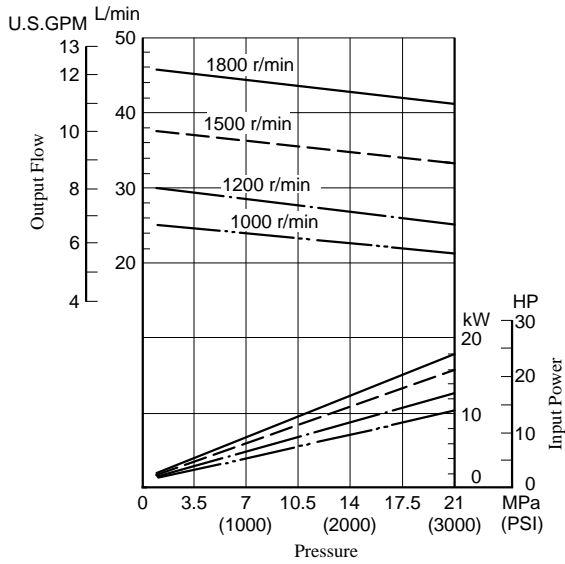

● PV2R1-31

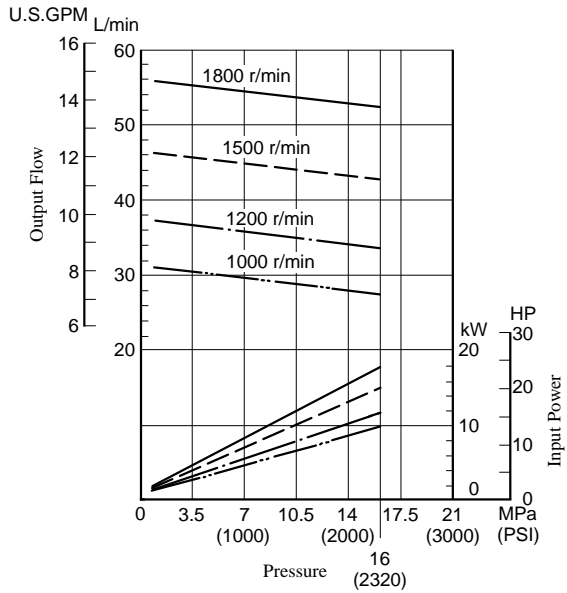

● PV2R2-41

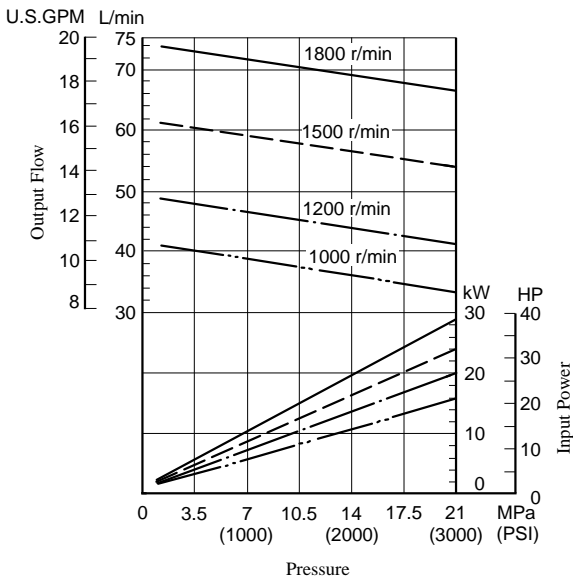

● PV2R2-47

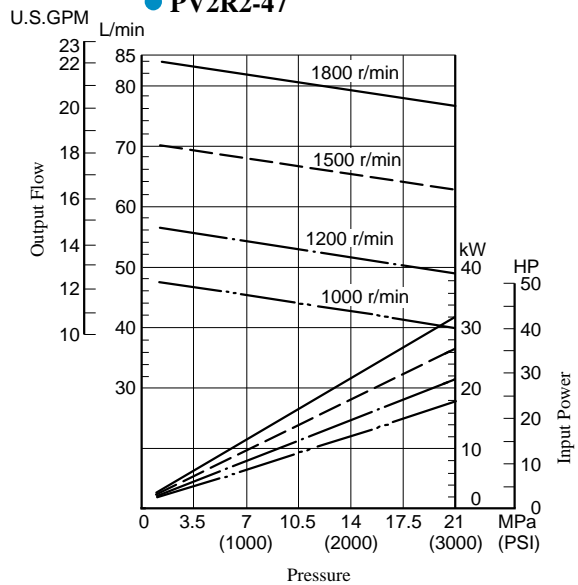

Viscosity 20 mm²/s (100 SSU) [ISO VG32 Oils, 50°C (122°F)]

● **PV2R2-53**

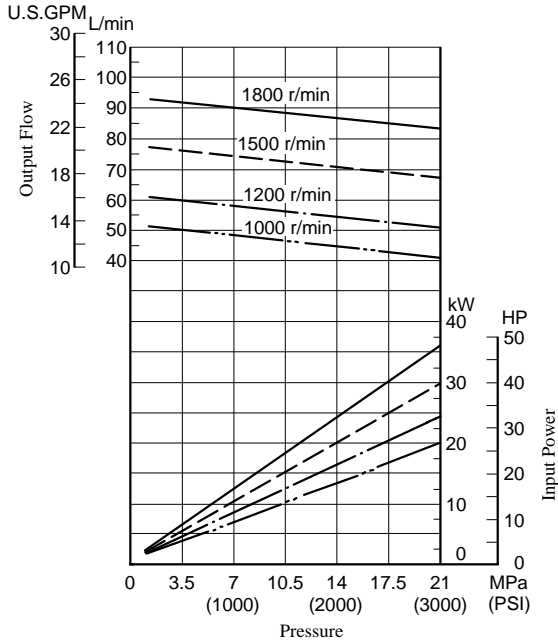

● **PV2R2-59**

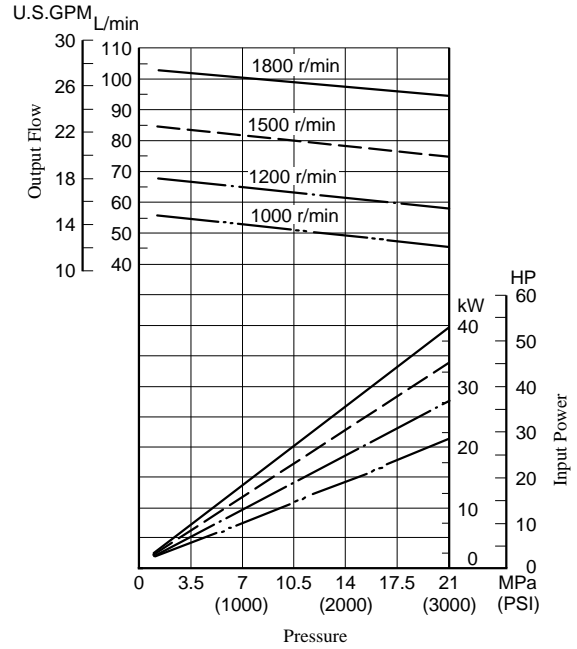

● **PV2R2-65**

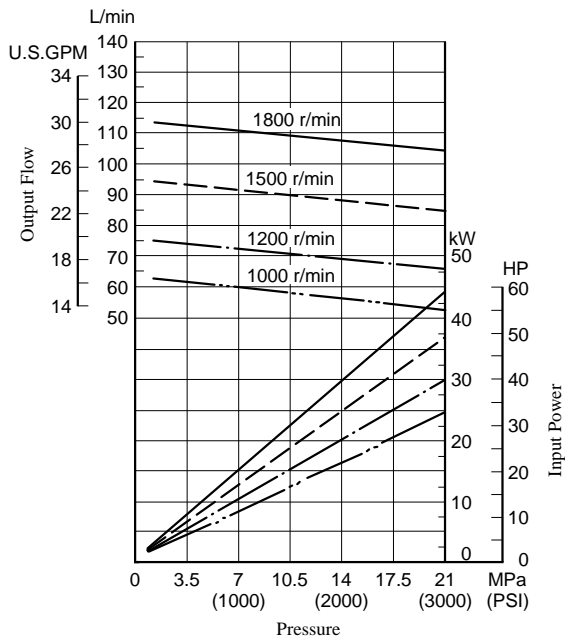

Viscosity 20 mm²/s (100 SSU) [ISO VG32 Oils, 50°C (122°F)]

● PV2R3-76

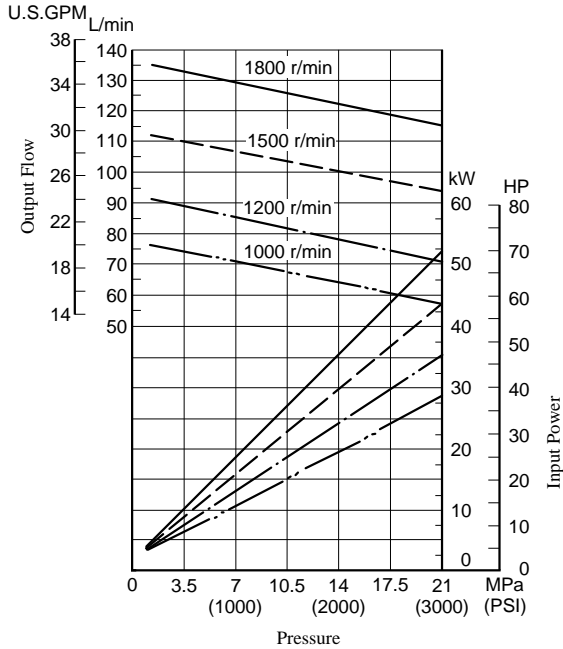

● PV2R3-94

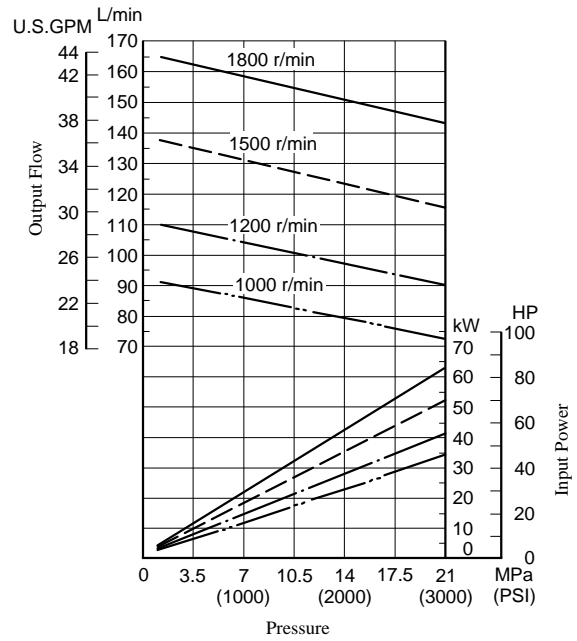

● PV2R3-116

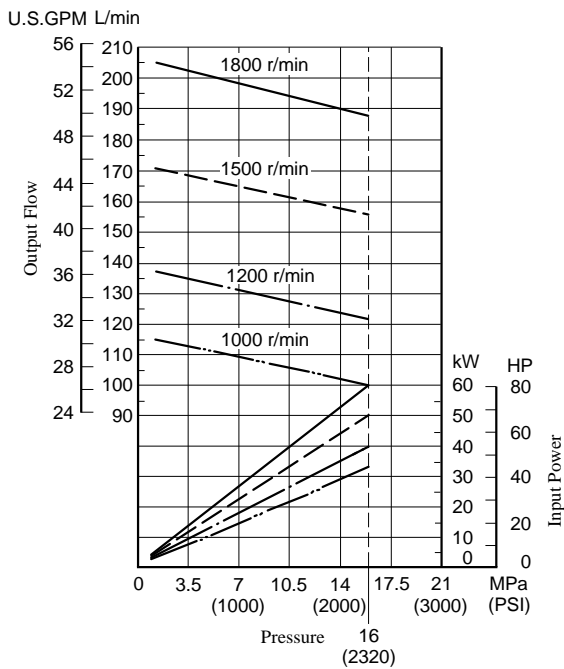

● PV2R4-136

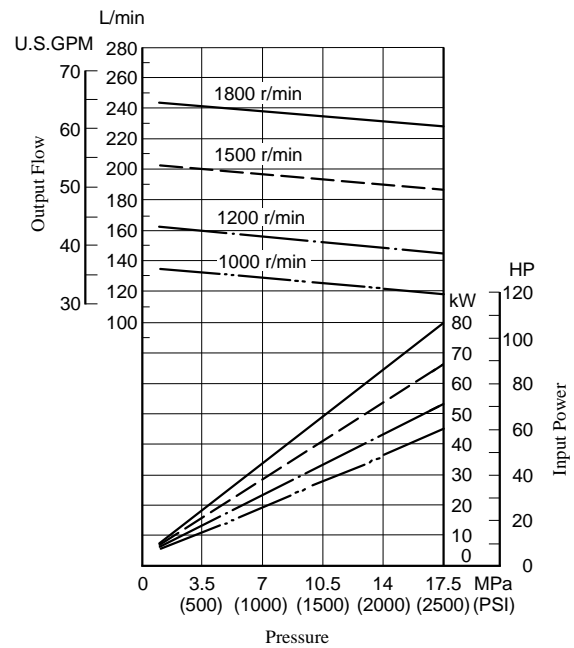

Viscosity 20 mm²/s (100 SSU) [ISO VG32 Oils, 50°C (122°F)]

● **PV2R4-153**

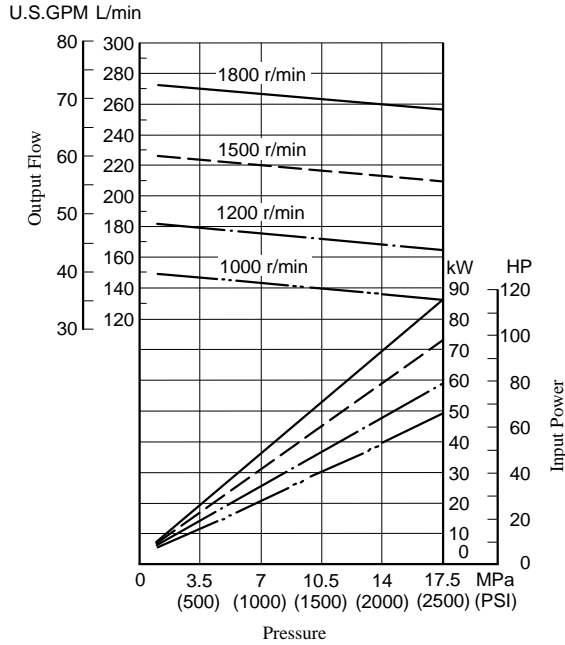

● **PV2R4-184**

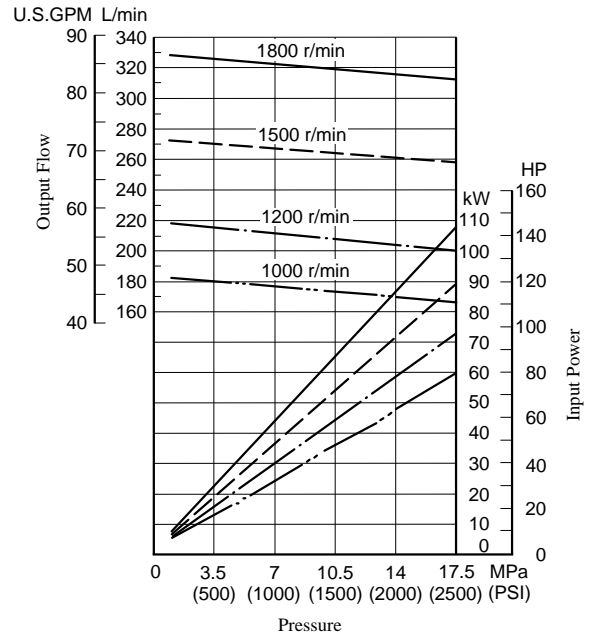

● **PV2R4-200**

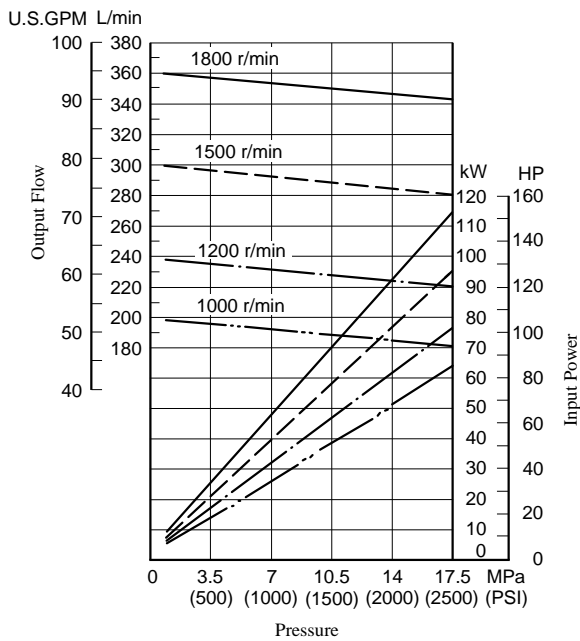

● **PV2R4-237**

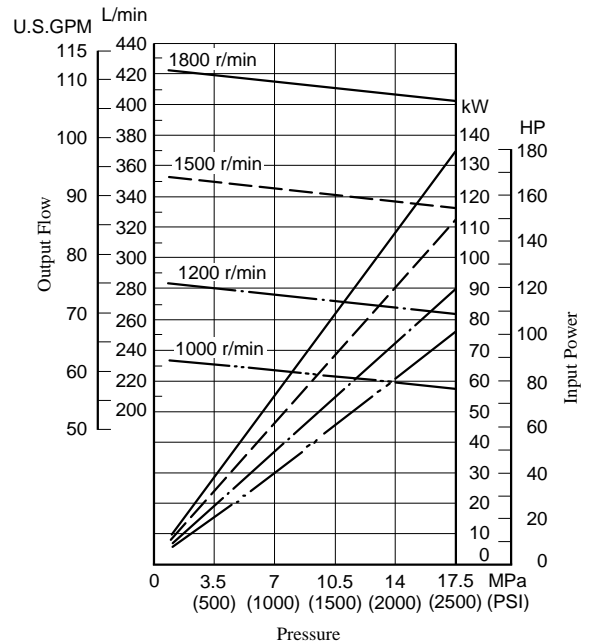

PV2R1-*-*-RAA-40/4090
PV2R2-*-*-RAA-40/4090
PV2R3-*-*-RAA-30/3090
PV2R4-*-*-RAA-30/3090

⚠ CAUTION

When making replacement of seals, bearings or cartridge kits, please do it carefully after reading through the relevant instructions in the Operator's Manual.

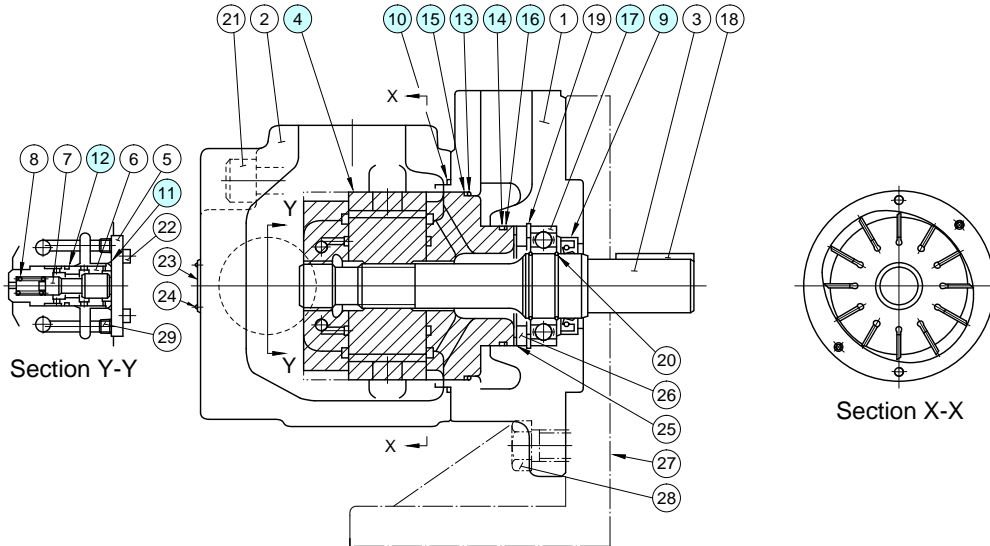

● Cartridge Kits

Model Numbers	④ Cartridge Kit Numbers	Model Numbers	④ Cartridge Kit Numbers
PV2R1-6-*-RAA-40*	CPV2R1-6-R-40	PV2R2-41-*-RAA-40*	CPV2R2-41-R-40
PV2R1-8-*-RAA-40*	CPV2R1-8-R-40	PV2R2-47-*-RAA-40*	CPV2R2-47-R-40
PV2R1-10-*-RAA-40*	CPV2R1-10-R-40	PV2R2-53-*-RAA-40*	CPV2R2-53-R-40
PV2R1-12-*-RAA-40*	CPV2R1-12-R-40	PV2R2-59-*-RAA-40*	CPV2R2-59-R-40
PV2R1-14-*-RAA-40*	CPV2R1-14-R-40	PV2R2-65-*-RAA-40*	CPV2R2-65-R-40
PV2R1-17-*-RAA-40*	CPV2R1-17-R-40	PV2R3-76-*-RAA-30*	CPV2R3-76-R-30
PV2R1-19-*-RAA-40*	CPV2R1-19-R-40	PV2R3-94-*-RAA-30*	CPV2R3-94-R-30
PV2R1-23-*-RAA-40*	CPV2R1-23-R-40	PV2R3-116-*-RAA-30*	CPV2R3-116-R-30
PV2R1-25-*-RAA-40*	CPV2R1-25-R-40	PV2R4-136-*-RAA-30*	CPV2R4-136-R-30
PV2R1-31-*-RAA-40*	CPV2R1-31-R-40	PV2R4-153-*-RAA-30*	CPV2R4-153-R-30
		PV2R4-184-*-RAA-30*	CPV2R4-184-R-30
		PV2R4-200-*-RAA-30*	CPV2R4-200-R-30
		PV2R4-237-*-RAA-30*	CPV2R4-237-R-30

● Seals & Bearings

Item	Name of Parts	Part Numbers				Qty.
		PV2R1	PV2R2	PV2R3	PV2R4	
9*	Oil Seal	ISD 26 42 8	ISD 30 42 8	ISD 35 55 11	ISD 45 68 12	1
10*	O-Ring	SO-NB-G80	SO-NB-G105	SO-NB-G135	SO-NB-G145	1
11*	O-Ring	---	---	---	SO-NB-P28	1
12*	O-Ring	---	---	---	SO-NB-P22A	1
13*	O-Ring	SO-NB-G60	SO-NB-G85	SO-NB-G115	SO-NA-G130	1
14*	O-Ring	SO-NB-G30	SO-NB-P46	SO-NB-A231	SO-NA-G80	1
15*	Back Up Ring	---	---	---	SO-BE-G130	1
16*	Back Up Ring	---	---	---	SO-BB-G80	1
17	Bearing	6004	6205	6207	6209	1

Note: 1) Item Nos. ⑬ and ⑭ (o-rings) and ⑮ and ⑯ (back up rings) are included in cartridge kit.

2) For pumps for phosphate ester type hydraulic fluids different part Nos. are used. Please contact us.

★ When ordering seals, please specify the kit number from the table right.

Pump Model Numbers	Seal Kit Numbers
PV2R1-*-*-RAA-40/4090	KS-PV2R1-40
PV2R2-*-*-RAA-40/4090	KS-PV2R2-40
PV2R3-*-*-RAA-30/3090	KS-PV2R3-30
PV2R4-*-*-RAA-30/3090	KS-PV2R4-30

Model Number Designation

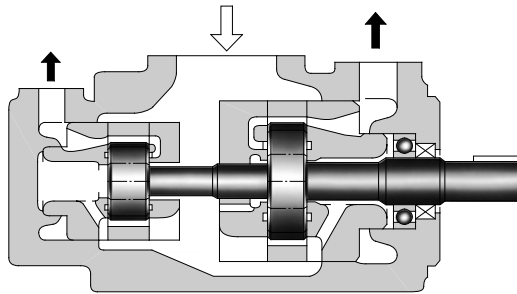
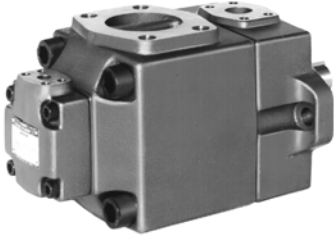

Graphic Symbols

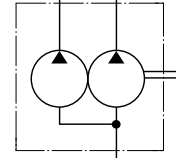

Model Number Designation

F-	PV2R13	-6	-76	-L	-R	A	A	A	-40	*
Special Seals	Series Number	Small Volume Pump Nominal Displacement cm ³ /rev	Large Volume Pump Nominal Displacement cm ³ /rev	Mounting	Direction of Rotation	Small Volume Pump Discharge Port Position	Large Volume Pump Discharge Port Position	Suction Port Position	Design Number	Design Standards
F: Special seals for phosphate ester type fluids (Omit if not required)	PV2R12	6, 8 10, 12 14, 17 19, 23 25, 31	26, 33 41, 47 53, 59 65	L: Foot Mtg.	R: ^{★1} Clockwise (Normal)	(Viewed from Shaft End)		A: Upwards (Normal)	40	Refer to ^{★2}
	PV2R13	6, 8 10, 12 14, 17 19, 23 25, 31	76, 94 116			A: Upwards (Normal)	40			
	PV2R23	41, 47 53, 59 65	52, 60 66, 76 94, 116			E: Left 45° Upwards (Normal)	40			
	PV2R33	76, 94 116	76, 94 116	F: Flange Mtg.		A: Upwards (Normal)	30			
	PV2R14	6, 8 10, 12 14, 17 19, 23	136, 153 184, 200 237			A: Upwards (Normal)	30			
	PV2R24	26, 33 41, 47				A: Upwards (Normal)	30			
	PV2R34	52, 60 66, 76 94, 116				E: Left 45° Upwards (Normal)	30			

★1. Available to supply pump with anti-clockwise rotation.
 Consult Yuken for details.

★2. Design Standards: None Japanese Standard "JIS" and European Design Standard
 90 N. American Design Standard

Specifications

■ Specifications

● Maximum Operating Pressure

Nominal Displacement cm ³ /rev	Max. Operating Pressure MPa (PSI)					
	Petroleum Base Oils		Water Containing Fluids			Synthetic Fluids
	Anti-Wear Type	R & O Type	Anti-Wear ^{★1} Type Water Glycols	Water Glycols	Water in Oil Emulsions	Phosphate Esters
6	21 ^{★2} (3050)	16 (2320)	16 (2320)	7 (1020)	7 (1020)	16 (2320)
8						
10						
12						
14						
17						
19						
23 ^{★3}	21 ^{★3} (3050)					
25	21 (3050)					
31	16 (2320)					
26	21 (3050)	14 (2030)	16 (2320)	7 (1020)	7 (1020)	14 (2030)
33						
41						
47						
53						
59						
65						
52	21 (3050)	14 (2030)	16 (2320)	7 (1020)	7 (1020)	14 (2030)
60						
66						
76						
94						
116	16 (2320)					
136	17.5 (2540)	14 (2030)	16 (2320)	7 (1020)	7 (1020)	14 (2030)
153						
184						
200						
237						

Note: 1) For the relation between model (series) No. and nominal displacement, see the table below.

	Nominal Displacement, Large Volume Pump			
	26, 33, 41, 47, 53, 59, 65	52, 60, 66	76, 94, 116	136, 153, 184, 200, 237
Nominal Displacement, Small Volume Pump	6	PV2R12	PV2R13	PV2R14
	8			
	10			
	12			
	14			
	17			
	19			
	23			
	25			
	31			
26	PV2R23	PV2R24	PV2R34	
33				
41				
47				
53				
59	PV2R33	PV2R34	PV2R34	
65				
76				
94				
116				

2) As for PV2R12 and PV2R33 series, the sum of the input powers to small volume pump and large volume pump is limited against shaft speed as follows.

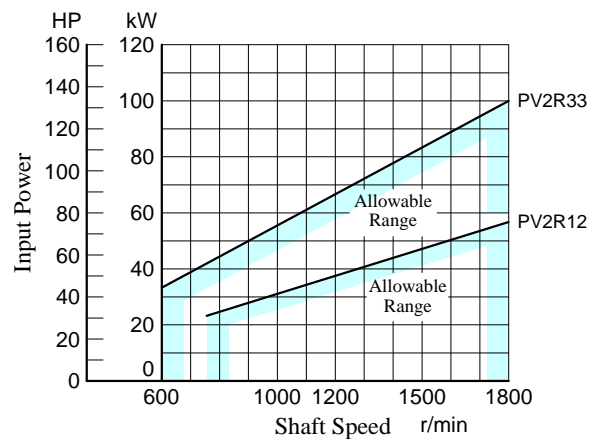

- ★ 1. For the brands of anti-wear water-glycols, see the item of "Hydraulic Fluids" on page 3.
- ★ 2. For pressures above 16 MPa (2320 PSI), raise the speed over 1450 r/min.
- ★ 3. If nominal displacement "23", of the PV2R14 series is selected, the maximum operating pressure is limited to 16 MPa (2320 PSI).

Specifications

● Shaft Speed Range

Model Numbers	Shaft Speed Range r/min			
	Petroleum Base Oils		Water Containing Fluids Phosphate Esters	
	Max.	Min.	Max.	Min.
PV2R12	1800	750 ^{★3}	1200	750 ^{★3}
PV2R13	1800 ^{★2}	750 ^{★3}	1200	750 ^{★3}
PV2R23	1800 ^{★2}	600 ^{★3}	1200	600 ^{★3}
PV2R33	1800 ^{★2} (1500) ^{★1}	600	1200	600
PV2R14	1800 ^{★2}	750 ^{★3}	1200	750 ^{★3}
PV2R24	1800 ^{★2}	600 ^{★3}	1200	600 ^{★3}
PV2R34	1800 ^{★2}	600	1200	600

- ★1. For PV2R33-116-116, the maximum speed is limited to 1500 r/min.
- ★2. As for the models (nominal displacements) listed below, the minimum suction pressure are limited in relation to the shaft speed.
[For other models, the minimum suction pressure is -20 kPa (5.9 in. Hg vacuum) irrespective of speed.

Model Numbers	Min. Suction Pres. kPa (in. Hg Vacuum)	
	Less than 1700 r/min	1700 - 1800 r/min
PV2R13-*-116 PV2R23-*-116	-20 (5.9)	0 (0)
PV2R23-*-76 PV2R23-*-94 PV2R33-*-76	-20 (5.9)	-7 (1.97)
PV2R33-94-* PV2R33-116-* PV2R33-*-94 PV2R33-*-116	-20 (5.9)	0 (0)
PV2R14-*-237 PV2R24-*-237 PV2R34-*-237	-20 (5.9)	-13 (3.94)
PV2R34-116-*	-20 (5.9)	0 (0)

- ★3. For starting at low speed, the maximum viscosity is limited.
For details, see the item of "Hydraulic Fluids" on page 3.

● Output Flow & Input Power

The pump characteristics are the same as those for PV2R series single pumps. See the pages concerned.

Model Numbers	Output Flow & Input Power	
	Small Volume Pump	Large Volume Pump
PV2R12	Same as single pump "PV2R1", refer to pages 11 - 13.	Same as single pump "PV2R2", refer to pages 13&14. However, as for displacement of "26" and "33", refer to page 29.
PV2R13	Same as single pump "PV2R1", refer to pages 11 - 13.	Same as single pump "PV2R3", refer to page 15.
PV2R23	Same as single pump "PV2R2", refer to pages 13&14.	Same as single pump "PV2R3", refer to page 15. However, as for displacement of "52", "60" and "66", refer to pages 29&30.
PV2R33	Same as single pump "PV2R3", refer to page 15.	Same as single pump "PV2R3", refer to page 15.
PV2R14	Same as single pump "PV2R1", refer to pages 11 - 13.	Same as single pump "PV2R4", refer to pages 15&16.
PV2R24	Same as single pump "PV2R2", refer to pages 13&14. However, as for displacement of "26" and "33", refer to page 29.	
PV2R34	Same as single pump "PV2R3", refer to page 15. However, as for displacement of "52", "60" and "66", refer to pages 29&30.	

● Mass

Mounting	Model Numbers	Approx. Mass kg (lbs.)						
		PV2R12	PV2R13	PV2R23	PV2R33	PV2R14	PV2R24	PV2R34
Flange Mtg.		25 (55.1)	45.6 (101)	51 (113)	84 (185)	75 (165)	78 (172)	98 (216)
Foot Mtg.		29.3 (64.6)	55.6 (123)	61 (135)	94 (207)	100 (221)	103 (227)	123 (271)

■ Pipe Flange Kits

Pipe flange kits are available. When ordering, specify the kit the number from the table below.

Pump Model Numbers	Name of Port	Pipe Flange Kit Numbers						
		Threaded Connection			Socket Welding*		Butt Welding	
		Japanese Standard "JIS"	European Design Standard	N. American Design Standard	Japanese Standard "JIS" European Design Standard	N. American Design Standard	Japanese Standard "JIS" European Design Standard	N. American Design Standard
PV2R12	Suction	F5-16-A-10	F5-16-A-1080	F5-16-A-1090	F5-16-B-10	F5-16-B-1090	F5-16-C-10	F5-16-C-1090
	Large Discharge	F5-06-A-10	F5-06-A-1080	F5-06-A-1090	F5-06-B-10	F5-06-B-1090	F5-06-C-10	F5-06-C-1090
	Small Discharge	F5-04-A-10	F5-04-A-1080	F5-04-A-1090	F5-04-B-10	F5-04-B-1090	F5-04-C-10	F5-04-C-1090
PV2R13	Suction	F5-24-A-10	—	—	F5-24-B-10	F5-24-B-1090	F5-24-C-10	F5-24-C-1090
	Large Discharge	F5-10-A-10	F5-10-A-1080	F5-10-A-1090	F5-10-B-10	F5-10-B-1090	F5-10-C-10	F5-10-C-1090
	Small Discharge	F5-04-A-10	F5-04-A-1080	F5-04-A-1090	F5-04-B-10	F5-04-B-1090	F5-04-C-10	F5-04-C-1090
PV2R23	Suction	F5-24-A-10	—	—	F5-24-B-10	F5-24-B-1090	F5-24-C-10	F5-24-C-1090
	Large Discharge	F5-10-A-10	F5-10-A-1080	F5-10-A-1090	F5-10-B-10	F5-10-B-1090	F5-10-C-10	F5-10-C-1090
	Small Discharge	F5-06-A-10	F5-06-A-1080	F5-06-A-1090	F5-06-B-10	F5-06-B-1090	F5-06-C-10	F5-06-C-1090
PV2R33	Suction	F5-28-A-10	—	—	F5-28-B-10	F5-28-B-1090	F5-28-C-10	F5-28-C-1090
	Large Discharge	F5-10-A-10	F5-10-A-1080	F5-10-A-1090	F5-10-B-10	F5-10-B-1090	F5-10-C-10	F5-10-C-1090
	Small Discharge	F5-10-A-10	F5-10-A-1080	F5-10-A-1090	F5-10-B-10	F5-10-B-1090	F5-10-C-10	F5-10-C-1090
PV2R14	Suction	F5-28-A-10	—	—	F5-28-B-10	F5-28-B-1090	F5-28-C-10	F5-28-C-1090
	Large Discharge	F5-12-A-10	F5-12-A-1080	F5-12-A-1090	F5-12-B-10	F5-12-B-1090	F5-12-C-10	F5-12-C-1090
	Small Discharge	F5-04-A-10	F5-04-A-1080	F5-04-A-1090	F5-04-B-10	F5-04-B-1090	F5-04-C-10	F5-04-C-1090
PV2R24	Suction	F5-28-A-10	—	—	F5-28-B-10	F5-28-B-1090	F5-28-C-10	F5-28-C-1090
	Large Discharge	F5-12-A-10	F5-12-A-1080	F5-12-A-1090	F5-12-B-10	F5-12-B-1090	F5-12-C-10	F5-12-C-1090
	Small Discharge	F5-06-A-10	F5-06-A-1080	F5-06-A-1090	F5-06-B-10	F5-06-B-1090	F5-06-C-10	F5-06-C-1090
PV2R34	Suction	F5-32-A-10	—	—	F5-32-B-10	F5-32-B-1090	F5-32-C-10	F5-32-C-1090
	Large Discharge	F5-12-A-10	F5-12-A-1080	F5-12-A-1090	F5-12-B-10	F5-12-B-1090	F5-12-C-10	F5-12-C-1090
	Small Discharge	F5-10-A-10	F5-10-A-1080	F5-10-A-1090	F5-10-B-10	F5-10-B-1090	F5-10-C-10	F5-10-C-1090

★ In case of using socket welding flanges, there is a case where the operating pressure should be set lower than the normal because of strength of the flanges. Therefore, please pay cautious attention to the operating pressure when the socket welding flanges are used.

Notes: Special seals (Viton seals) are required when phosphate ester type fluids are used. (Prefix "F-" to the pipe flange kit number when ordering.)

● Details of the pipe flange kits are given in the Catalogue No. Pub. EC-3001.

Flange Mtg.: PV2R12-**-F-REAA-40/4090

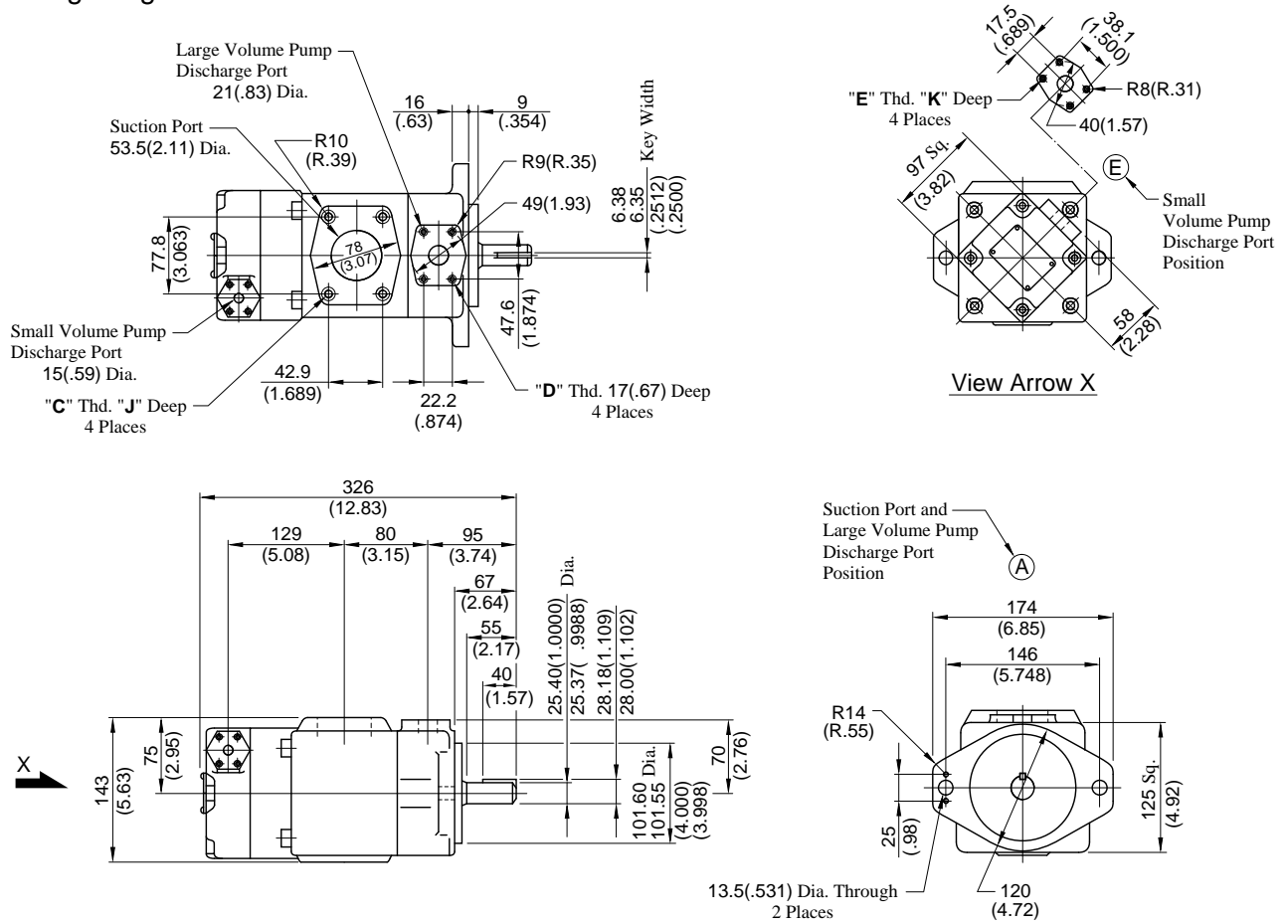

Model Numbers	"C" Thd.	"D" Thd.	"E" Thd.	Dimensions mm (Inches)	
				J	K
PV2R12-**-F-REAA-40	M12	M10	M8	19 (.75)	14 (.55)
PV2R12-**-F-REAA-4090	1/2-13 UNC	3/8-16 UNC	5/16-18 UNC	21 (.83)	16 (.63)

**DIMENSIONS IN
MILLIMETRES (INCHES)**

Foot Mtg.: PV2R12-**-L-REAA-40/4090

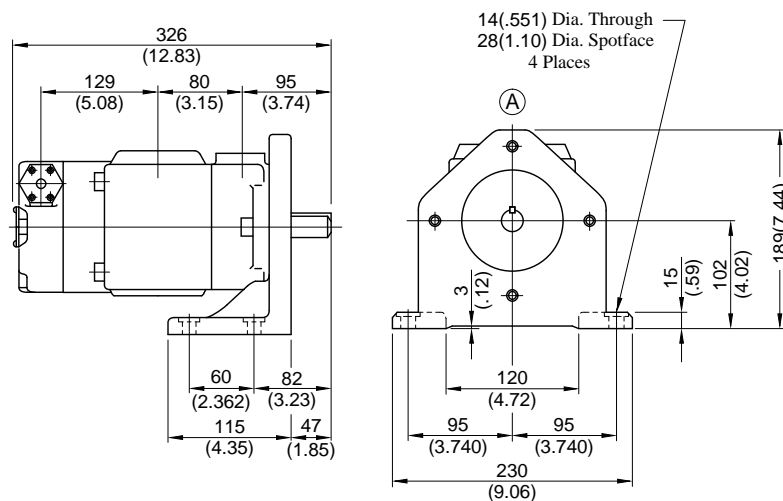

• For other dimensions, refer to "Flange Mtg.".

Flange Mtg.: PV2R13-**-F-RAAA-40/4090

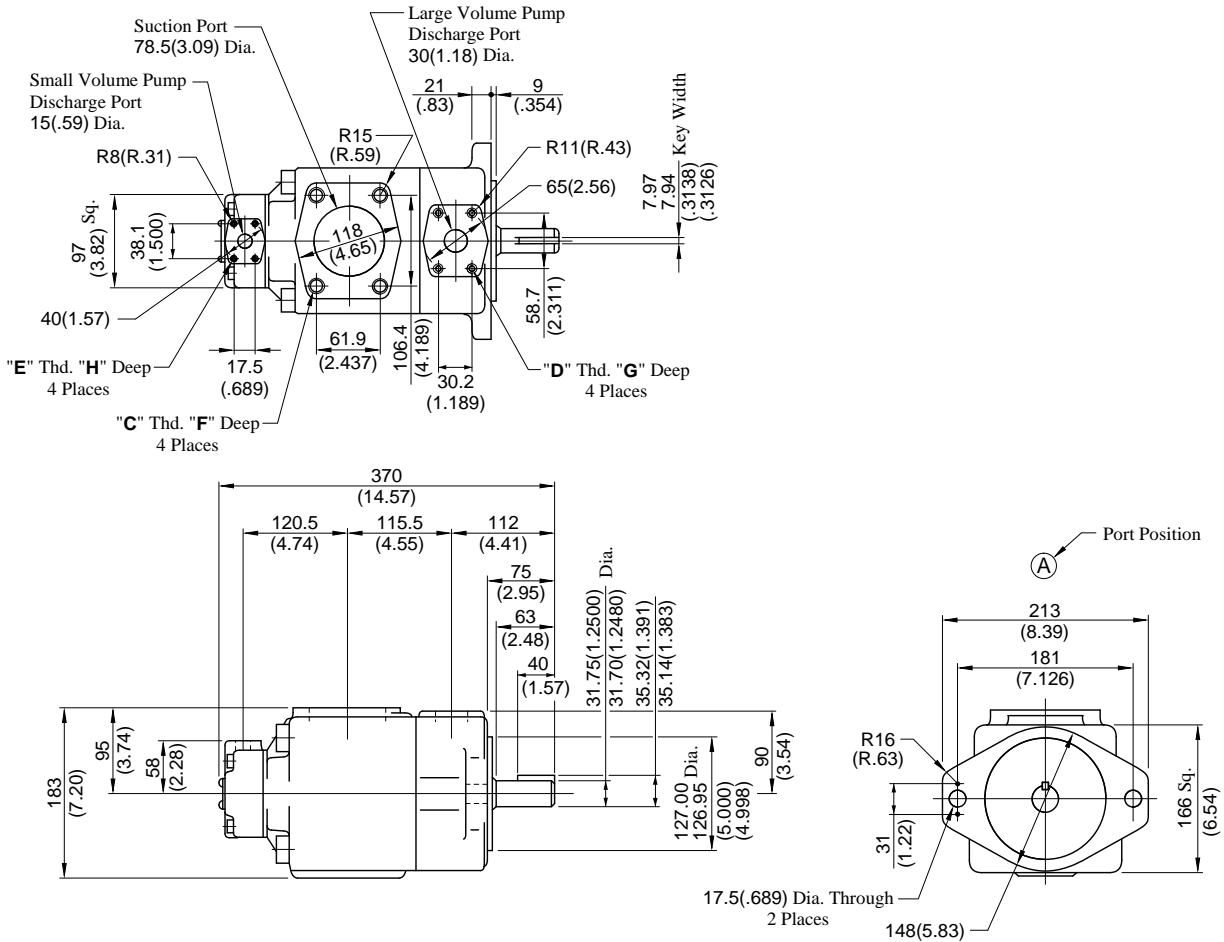

Model Numbers	"C" Thd.	"D" Thd.	"E" Thd.	Dimensions mm (Inches)		
				F	G	H
PV2R13-**-F-RAAA-40	M16	M10	M8	19 (.75)	19 (.75)	14 (.55)
PV2R13-**-F-RAAA-4090	5/8-11 UNC	7/16-14 UNC	5/16-18 UNC	21 (.83)	20 (.79)	16 (.63)

DIMENSIONS IN
MILLIMETRES (INCHES)

Foot Mtg.: PV2R13-**-L-RAAA-40/4090

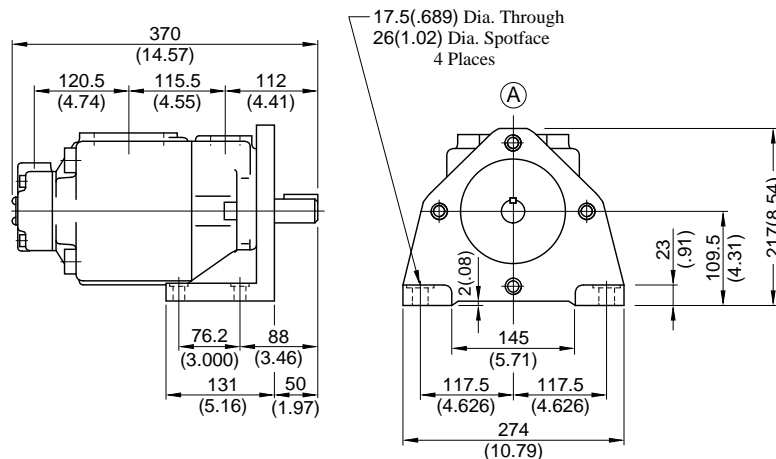

• For other dimensions, refer to "Flange Mtg.".

Flange Mtg.: PV2R23-**-F-REAA-40/4090

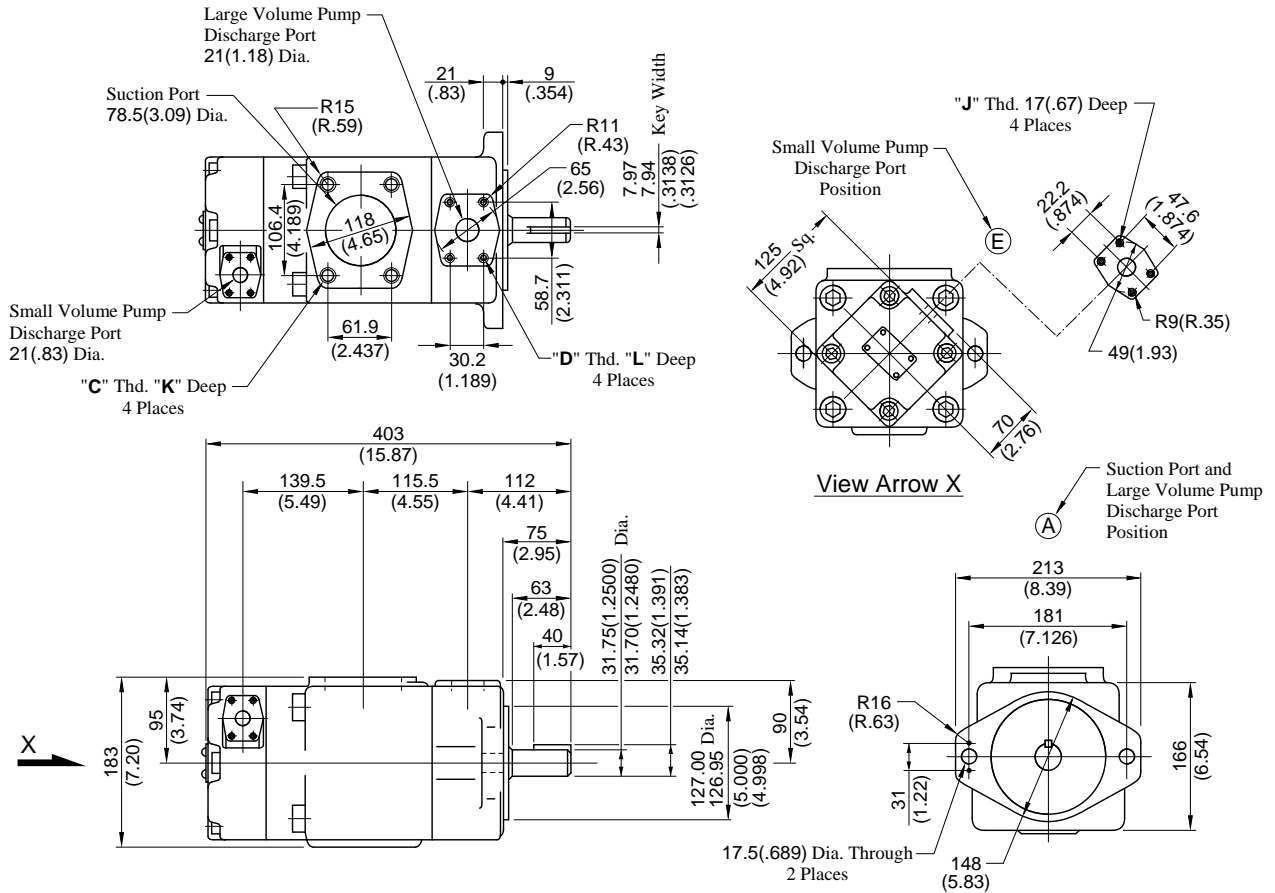

Model Numbers	"C" Thd.	"D" Thd.	"J" Thd.	Dimensions mm (Inches)	
				K	L
PV2R23-**-F-REAA-40	M16	M10	M10	19 (.75)	19 (.75)
PV2R23-**-F-REAA-4090	5/8-11 UNC	7/16-14 UNC	3/8-16 UNC	21 (.83)	20 (.79)

**DIMENSIONS IN
MILLIMETRES (INCHES)**

Foot Mtg.: PV2R23-**-L-REAA-40/4090

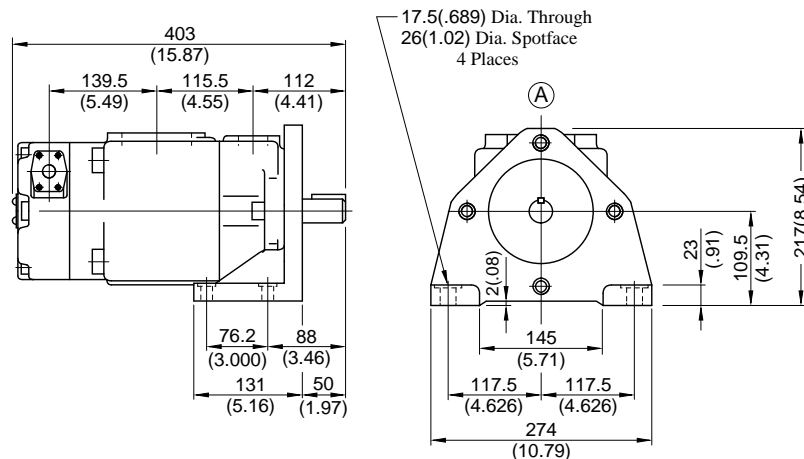

• For other dimensions, refer to "Flange Mtg.".

Flange Mtg.: PV2R33-*-F-RAAA-30/3090

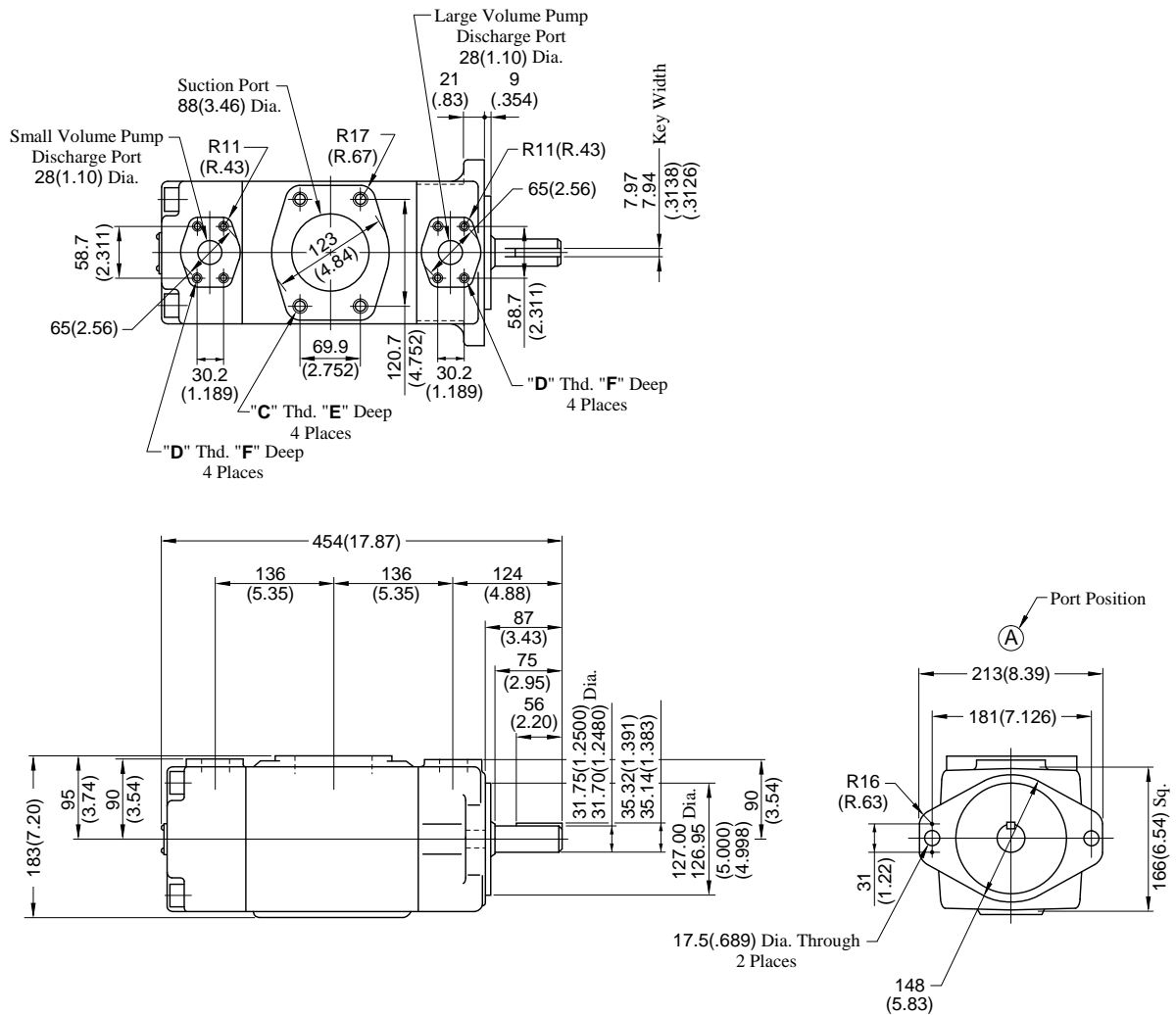

Model Numbers	"C" Thd.	"D" Thd.	Dimensions mm (Inches)	
			E	F
PV2R33-*-F-RAAA-30	M16	M10	19 (.75)	19 (.75)
PV2R33-*-F-RAAA-3090	5/8-11 UNC	7/16-14 UNC	21 (.83)	20 (.79)

**DIMENSIONS IN
MILLIMETRES (INCHES)**

Foot Mtg.: PV2R33-*-L-RAAA-30/3090

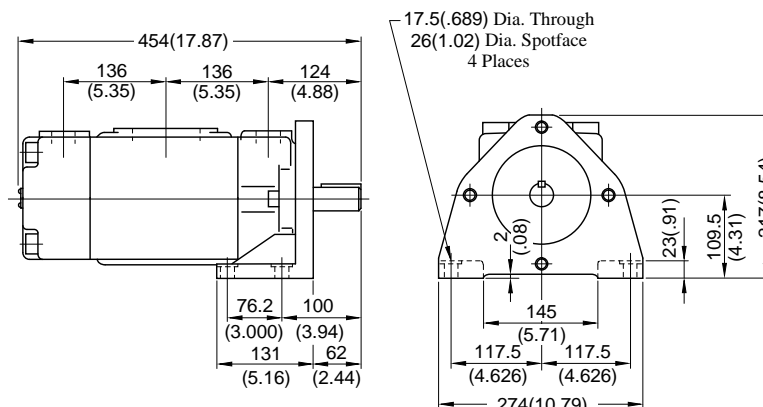

• For other dimensions, refer to "Flange Mtg.".

Flange Mtg.: PV2R14-**-F-RAAA-30/3090

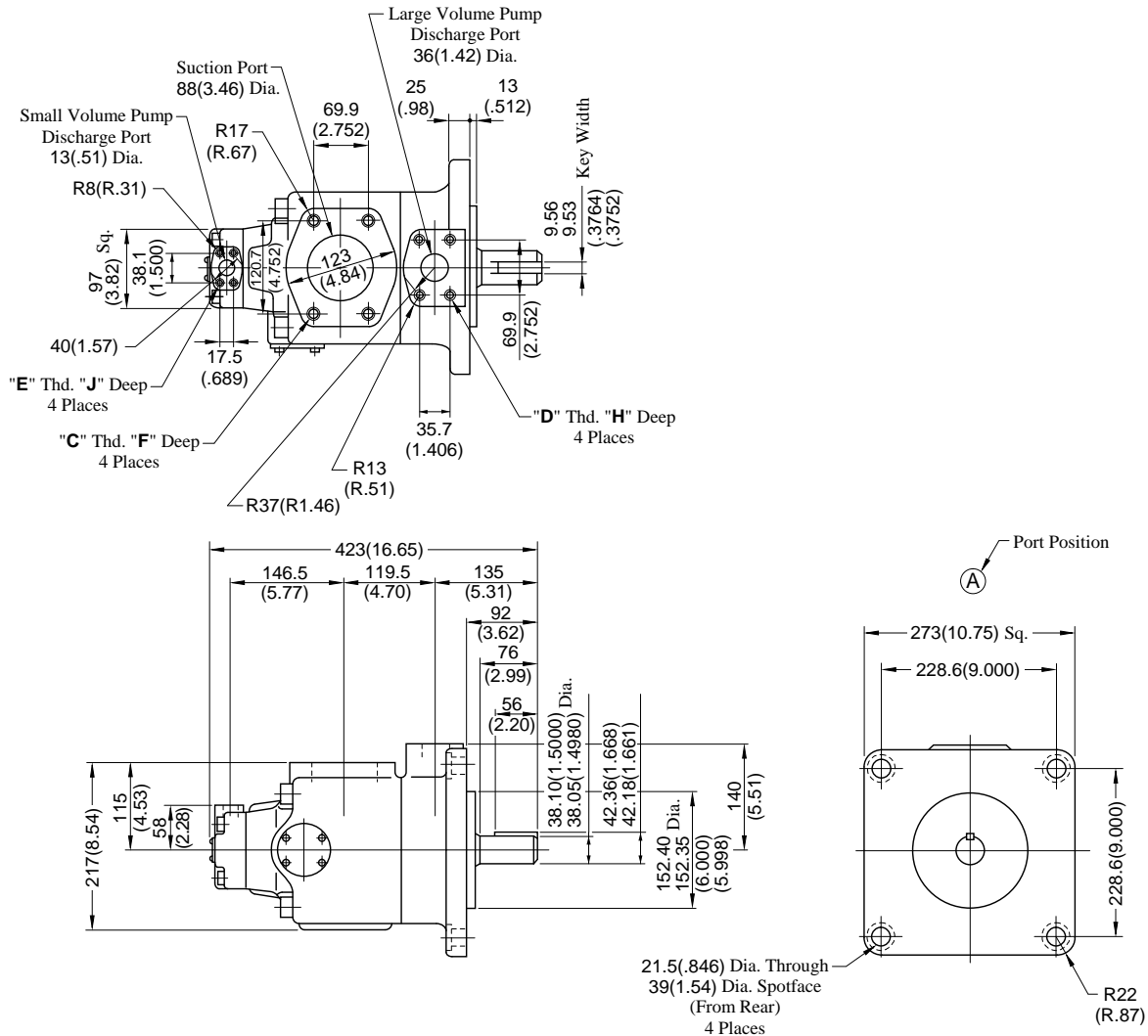

Model Numbers	"C" Thd.	"D" Thd.	"E" Thd.	Dimensions mm (Inches)		
				F	H	J
PV2R14-**-F-RAAA-30	M16	M12	M8	19 (.75)	19 (.75)	14 (.55)
PV2R14-**-F-RAAA-3090	5/8-11 UNC	1/2-13 UNC	5/16-18 UNC	21 (.83)	21 (.83)	16 (.63)

DIMENSIONS IN MILLIMETRES (INCHES)

Foot Mtg.: PV2R14-**-L-RAAA-30/3090

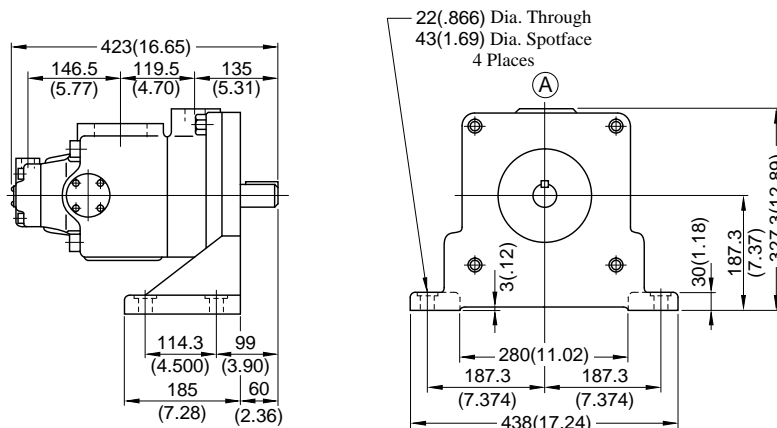

• For other dimensions, refer to "Flange Mtg.".

Flange Mtg.: PV2R24-*-F-RAAA-30/3090

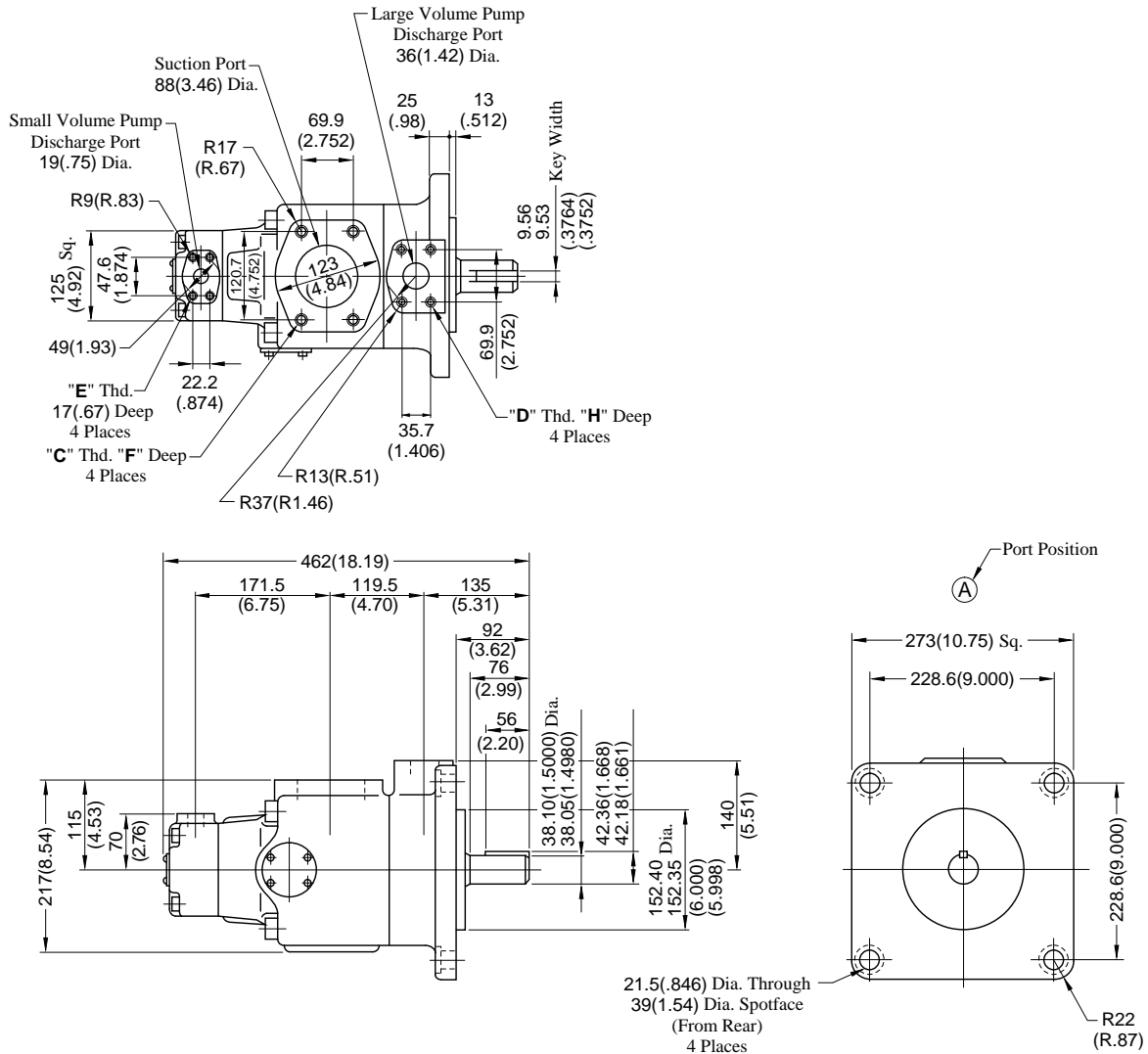

Model Numbers	"C" Thd.	"D" Thd.	"E" Thd.	Dimensions mm (Inches)	
				F	H
PV2R24-*-F-RAAA-30	M16	M12	M10	19 (.75)	19 (.75)
PV2R24-*-F-RAAA-3090	5/8-11 UNC	1/2-13 UNC	3/8-16 UNC	21 (.83)	21 (.83)

**DIMENSIONS IN
MILLIMETRES (INCHES)**

Foot Mtg.: PV2R24-*-L-RAAA-30/3090

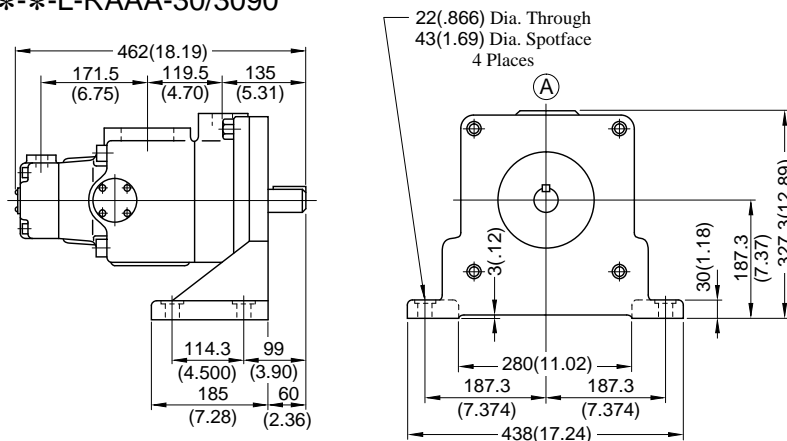

• For other dimensions, refer to "Flange Mtg.".

Flange Mtg.: PV2R34-**-F-REAA-30/3090

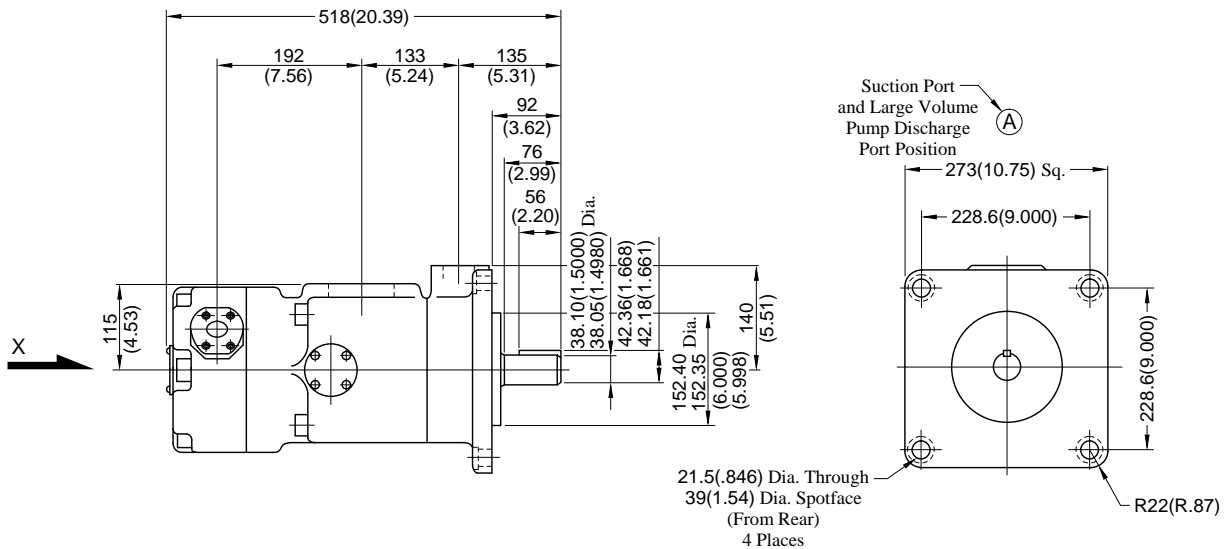
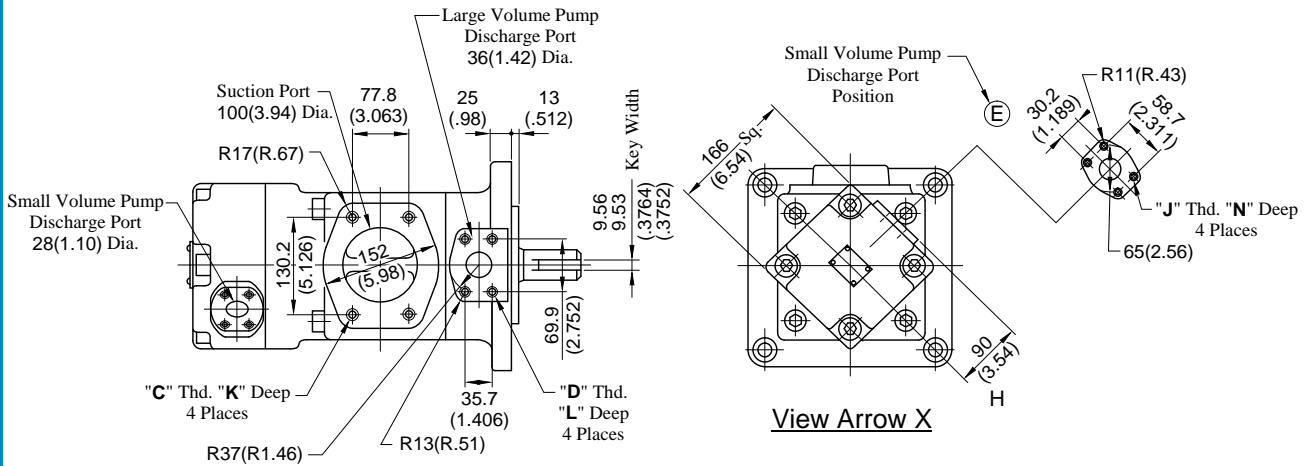

Model Numbers	"C" Thd.	"D" Thd.	"J" Thd.	Dimensions mm (Inches)		
				K	L	N
PV2R34-**-F-REAA-30	M16	M12	M8	19 (.75)	19 (.75)	19 (.75)
PV2R34-**-F-REAA-3090	5/8-11 UNC	1/2-14 UNC	7/16-14 UNC	21 (.83)	21 (.83)	20 (.79)

DIMENSIONS IN MILLIMETRES (INCHES)

Foot Mtg.: PV2R34-**-L-REAA-30/3090

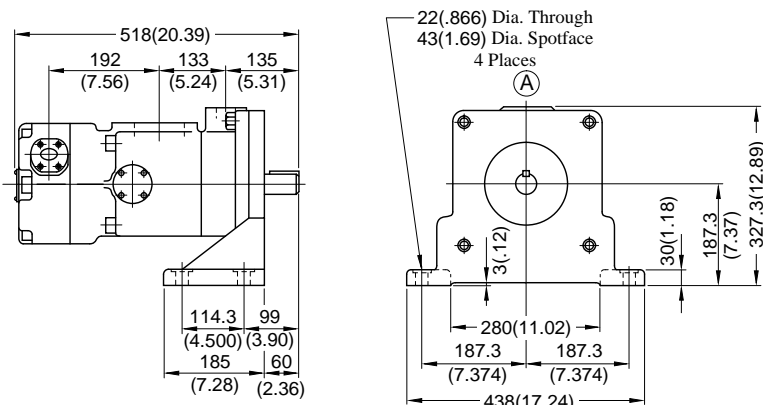

• For other dimensions, refer to "Flange Mtg.".

Viscosity 20 mm²/s (100 SSU) [ISO VG32 Oils, 50°C (122°F)]

- PV2R12-*-26
- PV2R24-26-*

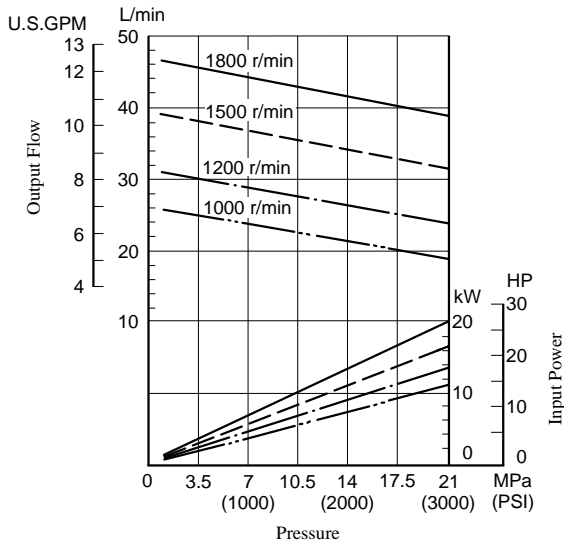

- PV2R12-*-33
- PV2R24-33-*

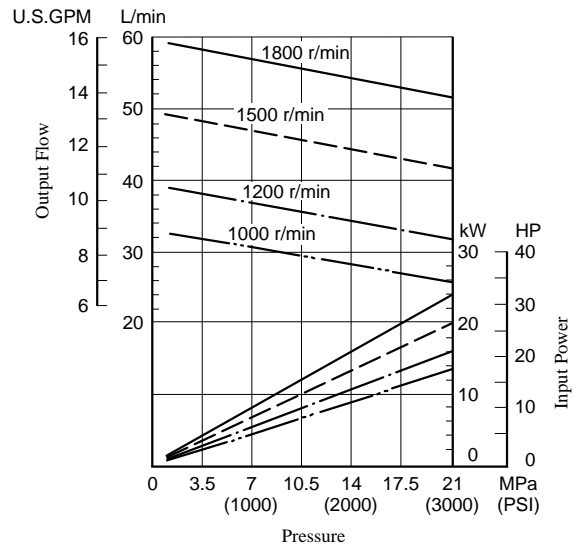

- PV2R23-*-52
- PV2R34-52-*

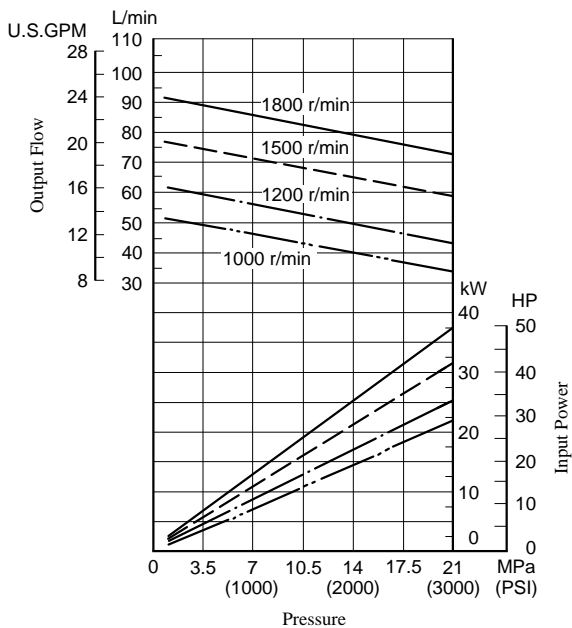

- PV2R23-*-60
- PV2R34-60-*

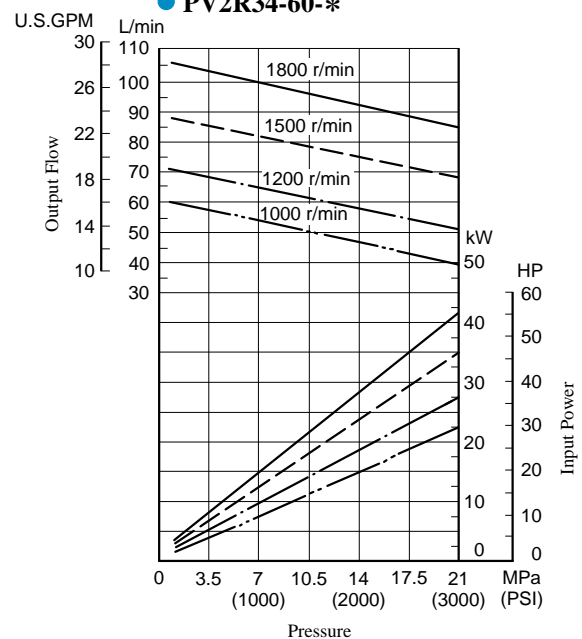

Viscosity 20 mm²/s (100 SSU) [ISO VG32 Oils, 50°C (122°F)]

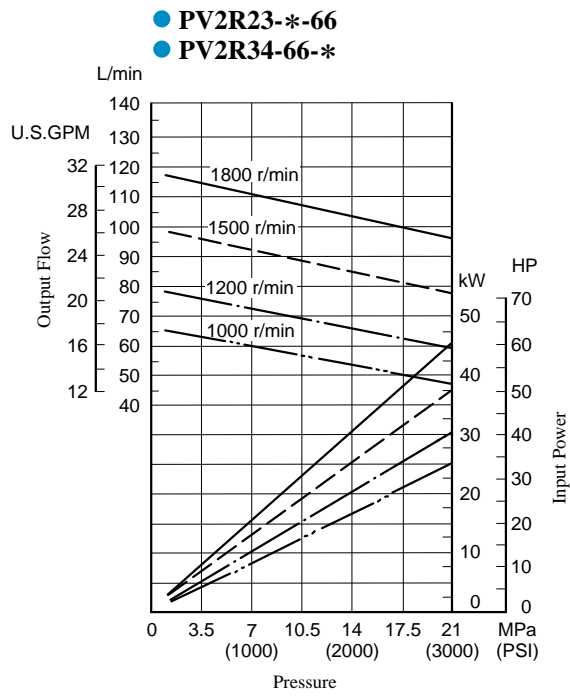

Spare Parts List

PV2R12-**-**-REAA-40/4090
 PV2R13-**-**-RAAA-40/4090
 PV2R23-**-**-REAA-40/4090
 PV2R33-**-**-RAAA-30/3090

CAUTION

When making replacement of seals, bearing or cartridge kits, please do it carefully after reading through the relevant instructions in the Operator's Manual.

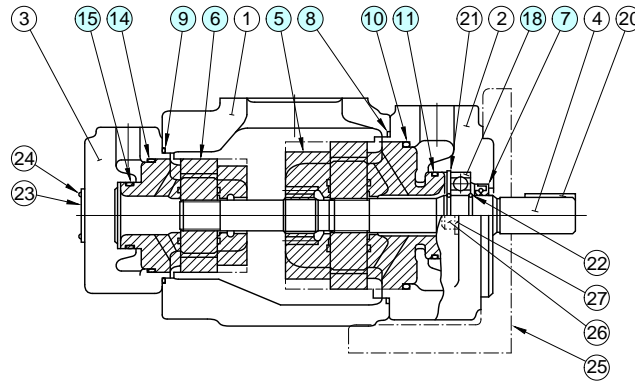

Cartridge Kits

Model Numbers	Cartridge Kit Numbers		Model Numbers	Cartridge Kit Numbers	
	⑥ Small Volume Pump	⑤ Large Volume Pump		⑥ Small Volume Pump	⑤ Large Volume Pump
PV2R12-6-★-**-REAA-40*	CPV2R13-6-L-40	CPV2R2 -★-R-40	PV2R13-6-★-**-RAAA-40*	CPV2R13-6-L-40	CPV2R3 -★-R-30
PV2R12-8-★-**-REAA-40*	CPV2R13-8-L-40		PV2R13-8-★-**-RAAA-40*	CPV2R13-8-L-40	
PV2R12-10-★-**-REAA-40*	CPV2R13-10-L-40		PV2R13-10-★-**-RAAA-40*	CPV2R13-10-L-40	
PV2R12-12-★-**-REAA-40*	CPV2R13-12-L-40		PV2R13-12-★-**-RAAA-40*	CPV2R13-12-L-40	
PV2R12-14-★-**-REAA-40*	CPV2R13-14-L-40		PV2R13-14-★-**-RAAA-40*	CPV2R13-14-L-40	
PV2R12-17-★-**-REAA-40*	CPV2R13-17-L-40		PV2R13-17-★-**-RAAA-40*	CPV2R13-17-L-40	
PV2R12-19-★-**-REAA-40*	CPV2R13-19-L-40		PV2R13-19-★-**-RAAA-40*	CPV2R13-19-L-40	
PV2R12-23-★-**-REAA-40*	CPV2R13-23-L-40		PV2R13-23-★-**-RAAA-40*	CPV2R13-23-L-40	
PV2R12-25-★-**-REAA-40*	CPV2R13-25-L-40		PV2R13-25-★-**-RAAA-40*	CPV2R13-25-L-40	
PV2R12-31-★-**-REAA-40*	CPV2R13-31-L-40		PV2R13-31-★-**-RAAA-40*	CPV2R13-31-L-40	
PV2R23-41-★-**-REAA-40*	CPV2R23-41-L-40	CPV2R33 -★-R-30	PV2R33-76-★-**-RAAA-30*	CPV2R33-76-L-30	
PV2R23-47-★-**-REAA-40*	CPV2R23-47-L-40		PV2R33-94-★-**-RAAA-30*	CPV2R33-94-L-30	
PV2R23-53-★-**-REAA-40*	CPV2R23-53-L-40		PV2R33-116-★-**-RAAA-30*	CPV2R33-116-L-30	
PV2R23-59-★-**-REAA-40*	CPV2R23-59-L-40				
PV2R23-65-★-**-REAA-40*	CPV2R23-65-L-40				

Note: Each **ab** above is a space for large volume pump nominal displacement. Referring to the model No. designation on page 18, write the correct nominal displacement figures.

Seals & Bearings

Item	Name of Parts	Part Numbers				Qty.
		PV2R12	PV2R13	PV2R23	PV2R33	
7★	Oil Seal	ISD 30 42 8	ISD 35 55 11	ISD 35 55 11	ISD 35 55 11	1
8★	O-Ring	SO-NB-G105	SO-NB-G135	SO-NB-G135	SO-NB-G135	1
9★	O-Ring	SO-NB-G80	SO-NB-G80	SO-NB-G105	SO-NB-G135	1
10★	O-Ring	SO-NB-G85	SO-NB-G115	SO-NB-G115	SO-NB-G115	1
11★	O-Ring	SO-NB-P46	SO-NB-A231	SO-NB-A231	SO-NB-A231	1
14★	O-Ring	SO-NB-G60	SO-NB-G60	SO-NB-G85	SO-NB-G115	1
15★	O-Ring	SO-NB-G30	SO-NB-G30	SO-NB-P46	SO-NB-A231	1
18	Bearing	6205	6207	6207	6207	1
19	Bearing	—	—	—	6305	1

Note: 1) The o-rings under item. Nos. 10 and 11 are included in the large volume pump cartridge kit and those under item. Nos. 14 and 15 in the small volume pump cartridge kit.

2) For pumps for phosphate ester type hydraulic fluids, different part Nos. are used. Please contact us.

★ When ordering seals, please specify the seal kit number from the table right.

Pump Model Numbers	Seal Kit Numbers
PV2R12-**-**-REAA-40*	KS-PV2R12-40
PV2R13-**-**-RAAA-40*	KS-PV2R13-40
PV2R23-**-**-REAA-40*	KS-PV2R23-40
PV2R33-**-**-RAAA-30*	KS-PV2R33-30

Spare Parts List

PV2R14-***-RAAA-30/3090
PV2R24-***-RAAA-30/3090
PV2R34-***-REAA-30/3090

CAUTION

When making replacement of seals, bearing or cartridge kits, please do it carefully after reading through the relevant instructions in the Operator's Manual.

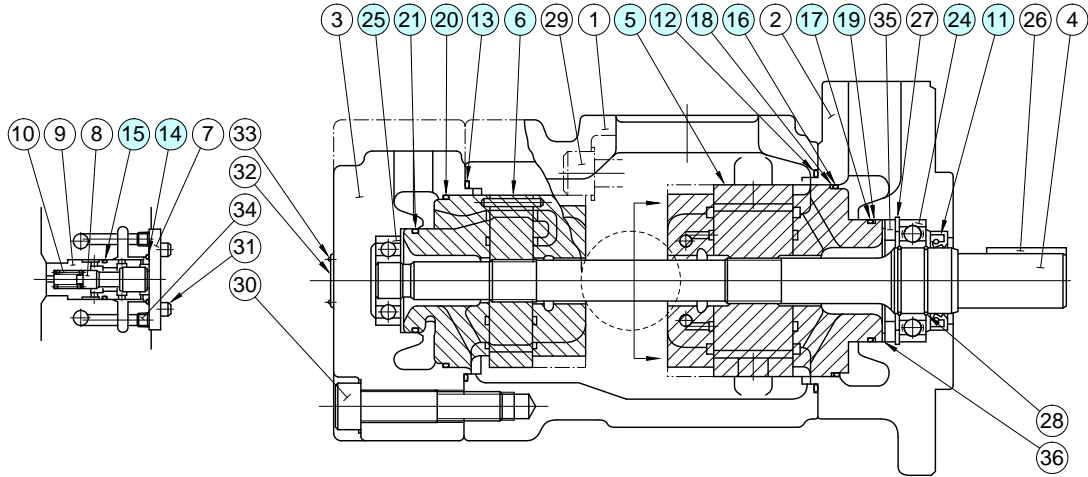

● Cartridge Kits

Model Numbers	Cartridge Kit Numbers		Model Numbers	Cartridge Kit Numbers	
	⑥ Small Volume Pump	⑤ Large Volume Pump		⑥ Small Volume Pump	⑤ Large Volume Pump
PV2R14-6-★-*-RAAA-30*	CPV2R13-6-L-30	CPV2R2 ★-R-40	PV2R24-26-★-*-RAAA-30*	CPV2R23-26-L-30	CPV2R4 ★-R-30
PV2R14-8-★-*-RAAA-30*	CPV2R13-8-L-30		PV2R24-33-★-*-RAAA-30*	CPV2R23-33-L-30	
PV2R14-10-★-*-RAAA-30*	CPV2R13-10-L-30		PV2R24-41-★-*-RAAA-30*	CPV2R23-41-L-30	
PV2R14-12-★-*-RAAA-30*	CPV2R13-12-L-30		PV2R24-47-★-*-RAAA-30*	CPV2R23-47-L-30	
PV2R14-14-★-*-RAAA-30*	CPV2R13-14-L-30		PV2R34-52-★-*-REAA-30*	CPV2R33-52-L-30	CPV2R34 ★-R-30
PV2R14-17-★-*-RAAA-30*	CPV2R13-17-L-30		PV2R34-60-★-*-REAA-30*	CPV2R33-60-L-30	
PV2R14-19-★-*-RAAA-30*	CPV2R13-19-L-30		PV2R34-66-★-*-REAA-30*	CPV2R33-66-L-30	
PV2R14-23-★-*-RAAA-30*	CPV2R13-23-L-30		PV2R34-76-★-*-REAA-30*	CPV2R33-76-L-30	
		PV2R34-94-★-*-REAA-30*	CPV2R33-94-L-30		
		PV2R34-116-★-*-REAA-30*	CPV2R33-116-L-30		

Note: The ★ marks are spaces for large volume pump nominal displacements. Referring to the model No. designation on page 18, write correct nominal displacement figures.

● Seals & Bearings

Item	Name of Parts	Part Numbers			Qty.
		PV2R14	PV2R24	PV2R34	
11★	Oil Seal	ISD 45 68 12	ISD 45 68 12	ISD 45 68 12	1
12★	O-Ring	SO-NB-G145	SO-NB-G145	SO-NB-G145	1
13★	O-Ring	SO-NB-G80	SO-NB-G105	SO-NB-G135	1
14★	O-Ring	SO-NB-P28	SO-NB-P28	SO-NB-P28	1
15★	O-Ring	SO-NB-P22A	SO-NB-P22A	SO-NB-P22A	1
16★	O-Ring	SO-NA-G130	SO-NA-G130	SO-NA-G130	1
17★	O-Ring	SO-NA-G80	SO-NA-G80	SO-NA-G80	1
18★	Back Up Ring	SO-BE-G130	SO-BE-G130	SO-BE-G130	1
19★	Back Up Ring	SO-BB-G80	SO-BB-G80	SO-BB-G80	1
20★	O-Ring	SO-NB-G60	SO-NB-G85	SO-NB-G115	1
21★	O-Ring	SO-NB-G30	SO-NB-P46	SO-NB-A231	1
24	Bearing	6209	6209	6209	1
25	Bearing	—	—	6305	1

Note: 1) The o-rings and back up rings under item. Nos. 16 to 19 are included in the large volume pump cartridge kit and those under item. Nos. 20 and 21 in the small volume pump cartridge kit.

2) For pumps for phosphate ester type hydraulic fluids, different part Nos. are used. Please contact us.

★ When ordering seals, please specify the seal kit number from the table right.

Pump Model Numbers	Seal Kit Numbers
PV2R14-***-RAAA-30*	KS-PV2R14-30
PV2R24-***-RAAA-30*	KS-PV2R24-30
PV2R34-***-REAA-30*	KS-PV2R34-30